



Standard Test Method for Distillation of Petroleum Products at Atmospheric Pressure¹

This standard is issued under the fixed designation D86; the number immediately following the designation indicates the year of original adoption or, in the case of revision, the year of last revision. A number in parentheses indicates the year of last reapproval. A superscript epsilon (ϵ) indicates an editorial change since the last revision or reapproval.

This standard has been approved for use by agencies of the Department of Defense.

1. Scope*

1.1 This test method covers the atmospheric distillation of petroleum products using a laboratory batch distillation unit to determine quantitatively the boiling range characteristics of such products as light and middle distillates, automotive spark-ignition engine fuels with or without oxygenates (see **Note 1**), aviation gasolines, aviation turbine fuels, diesel fuels, biodiesel blends up to 20 %, marine fuels, special petroleum spirits, naphthas, white spirits, kerosines, and Grades 1 and 2 burner fuels.

NOTE 1—An interlaboratory study was conducted in 2008 involving 11 different laboratories submitting 15 data sets and 15 different samples of ethanol-fuel blends containing 25 v%, 50 v%, and 75 v% ethanol. The results indicate that the repeatability limits of these samples are comparable or within the published repeatability of the method (with the exception of FBP of 75% ethanol-fuel blends). On this basis, it can be concluded that Test Method D86 is applicable to ethanol-fuel blends such as Ed75 and Ed85 (Specification **D5798**) or other ethanol-fuel blends with greater than 10 v% ethanol. See ASTM RR: RR:D02-1694 for supporting data.²

1.2 The test method is designed for the analysis of distillate fuels; it is not applicable to products containing appreciable quantities of residual material.

1.3 This test method covers both manual and automated instruments.

1.4 Unless otherwise noted, the values stated in SI units are to be regarded as the standard. The values given in parentheses are provided for information only.

1.5 **WARNING**—Mercury has been designated by many regulatory agencies as a hazardous material that can cause central nervous system, kidney and liver damage. Mercury, or its vapor, may be hazardous to health and corrosive to materials. Caution should be taken when handling mercury and mercury containing products. See the applicable product Ma-

terial Safety Data Sheet (MSDS) for details and EPA's website—<http://www.epa.gov/mercury/faq.htm>—for additional information. Users should be aware that selling mercury and/or mercury containing products into your state or country may be prohibited by law.

1.6 *This standard does not purport to address all of the safety concerns, if any, associated with its use. It is the responsibility of the user of this standard to establish appropriate safety and health practices and determine the applicability of regulatory limitations prior to use.*

2. Referenced Documents

2.1 All standards are subject to revision, and parties to agreement on this test method are to apply the most recent edition of the standards indicated below, unless otherwise specified, such as in contractual agreements or regulatory rules where earlier versions of the method(s) identified may be required.

2.2 ASTM Standards:³

- [D97 Test Method for Pour Point of Petroleum Products](#)
- [D323 Test Method for Vapor Pressure of Petroleum Products \(Reid Method\)](#)
- [D4057 Practice for Manual Sampling of Petroleum and Petroleum Products](#)
- [D4175 Terminology Relating to Petroleum, Petroleum Products, and Lubricants](#)
- [D4177 Practice for Automatic Sampling of Petroleum and Petroleum Products](#)
- [D4953 Test Method for Vapor Pressure of Gasoline and Gasoline-Oxygenate Blends \(Dry Method\)](#)
- [D5190 Test Method for Vapor Pressure of Petroleum Products \(Automatic Method\)](#)
- [D5191 Test Method for Vapor Pressure of Petroleum Products \(Mini Method\)](#)
- [D5798 Specification for Fuel Ethanol \(Ed70-Ed85\) for Automotive Spark-Ignition Engines](#)
- [D5842 Practice for Sampling and Handling of Fuels for Volatility Measurement](#)

¹ This test method is under the jurisdiction of ASTM Committee **D02** on Petroleum Products and Lubricants and is the direct responsibility of Subcommittee **D02.08** on Volatility.

In the IP, the equivalent test method is published under the designation **IP 123**. It is under the jurisdiction of the Standardization Committee.

Current edition approved Aug. 1, 2010. Published August 2010. Originally approved in 1921. Last previous edition approved in 2010 as D86-10. DOI: 10.1520/D0086-10A.

² Supporting data have been filed at ASTM International Headquarters and may be obtained by requesting Research Report RR:D02-1694.

³ For referenced ASTM standards, visit the ASTM website, www.astm.org, or contact ASTM Customer Service at service@astm.org. For *Annual Book of ASTM Standards* volume information, refer to the standard's Document Summary page on the ASTM website.

*A Summary of Changes section appears at the end of this standard.

TABLE 1 Preparation of Apparatus and Specimen

	Group 1	Group 2	Group 3	Group 4
Flask, mL	125	125	125	125
ASTM distillation thermometer	7C (7F)	7C (7F)	7C (7F)	8C (8F)
IP distillation thermometer range	low	low	low	high
Flask support board	B	B	C	C
diameter of hole, mm	38	38	50	50
Temperature at start of test				
Flask				
°C	13–18	13–18	13–18	not above
°F	55–65	55–65	55–65	ambient
Flask support and shield	not above	not above	not above	ambient
ambient				
Receiving cylinder and sample				
°C	13–18	13–18	13–18 ^A	13–ambient ^A
°F	55–65	55–65	55–65 ^A	55–ambient ^A

^A See 10.3.1.1 for exceptions.

D5949 Test Method for Pour Point of Petroleum Products (Automatic Pressure Pulsing Method)

D5950 Test Method for Pour Point of Petroleum Products (Automatic Tilt Method)

D5985 Test Method for Pour Point of Petroleum Products (Rotational Method)

D6300 Practice for Determination of Precision and Bias Data for Use in Test Methods for Petroleum Products and Lubricants

E1 Specification for ASTM Liquid-in-Glass Thermometers

E77 Test Method for Inspection and Verification of Thermometers

E1272 Specification for Laboratory Glass Graduated Cylinders

E1405 Specification for Laboratory Glass Distillation Flasks

2.3 *Energy Institute Standards*:⁴

IP 69 Determination of Vapour Pressure—Reid Method

IP 123 Petroleum Products—Determination of Distillation Characteristics

IP 394 Determination of Air Saturated Vapour Pressure

IP Standard Methods for Analysis and Testing of Petroleum and Related Products 1996—Appendix A

3. Terminology

3.1 Definitions:

3.1.1 *charge volume, n*—the volume of the specimen, 100 mL, charged to the distillation flask at the temperature specified in Table 1.

3.1.2 *decomposition, n*—of a hydrocarbon, the pyrolysis or cracking of a molecule yielding smaller molecules with lower boiling points than the original molecule.

3.1.2.1 *Discussion*—Characteristic indications of thermal decomposition are evolution of fumes and erratic temperature readings that usually decrease after any attempt is made to adjust the heat.

3.1.3 *decomposition point, n*—the corrected thermometer reading that coincides with the first indications of thermal decomposition of the liquid in the flask.

3.1.3.1 *Discussion*—The decomposition point, as determined under the conditions of this test method, does not necessarily correspond to the decomposition temperature in other applications.

3.1.4 *dry point, n*—the corrected thermometer reading that is observed at the instant the last drop of liquid (exclusive of any drops or film of liquid on the side of the flask or on the temperature sensor), evaporates from the lowest point in the distillation flask.

3.1.4.1 *Discussion*—The end point (final boiling point), rather than the dry point, is intended for general use. The dry point can be reported in connection with special purpose naphthas, such as those used in the paint industry. Also, it is substituted for the end point (final boiling point) whenever the sample is of such a nature that the precision of the end point (final boiling point) cannot consistently meet the requirements given in the precision section.

3.1.5 *dynamic holdup, n*—the amount of material present in the neck of the flask, in the sidearm of the flask, and in the condenser tube during the distillation.

3.1.6 *emergent stem effect, n*—the offset in temperature reading caused by the use of total immersion mercury-in-glass thermometers in the partial immersion mode.

3.1.6.1 *Discussion*—In the partial immersion mode, a portion of the mercury thread, that is, the emergent portion, is at a lower temperature than the immersed portion, resulting in a shrinkage of the mercury thread and a lower temperature reading.

3.1.7 *end point (EP) or final boiling point (FBP), n*—the maximum corrected thermometer reading obtained during the test.

3.1.7.1 *Discussion*—This usually occurs after the evaporation of all liquid from the bottom of the flask. The term maximum temperature is a frequently used synonym.

3.1.8 *front end loss, n*—loss due to evaporation during transfer from receiving cylinder to distillation flask, vapor loss during the distillation, and uncondensed vapor in the flask at the end of the distillation.

3.1.9 *fuel ethanol (Ed75-Ed85)*—blend of ethanol and hydrocarbon of which the ethanol portion is nominally 75 to 85 volume % denatured fuel ethanol.

D4175

⁴ Available from Energy Institute, 61 New Cavendish St., London, WIG 7AR, U.K., <http://www.energyinst.org.uk>.

3.1.10 *initial boiling point (IBP), n*—the corrected thermometer reading that is observed at the instant the first drop of condensate falls from the lower end of the condenser tube.

3.1.11 *percent evaporated, n*—the sum of the percent recovered and the percent loss.

3.1.12 *percent loss (or observed loss), n*—one hundred minus the percent total recovery.

3.1.12.1 *corrected loss, n*—percent loss corrected for barometric pressure.

3.1.13 *percent recovered, n*—the volume of condensate observed in the receiving cylinder, expressed as a percentage of the charge volume, associated with a simultaneous temperature reading.

3.1.14 *percent recovery, n*—the maximum percent recovered, as observed in accordance with 10.18.

3.1.14.1 *corrected percent recovery, n*—the percent recovery, adjusted for the difference between the observed loss and the corrected loss, as described in Eq 8.

3.1.14.2 *percent total recovery, n*—the combined percent recovery and residue in the flask, as determined in accordance with 11.1.

3.1.15 *percent residue, n*—the volume of residue in the flask, measured in accordance with 10.19, and expressed as a percentage of the charge volume.

3.1.16 *rate of change (or slope), n*—the change in temperature reading per percent evaporated or recovered, as described in 13.2.

3.1.17 *temperature lag, n*—the offset between the temperature reading obtained by a temperature sensing device and the true temperature at that time.

3.1.18 *temperature measurement device, n*—a thermometer, as described in 6.3.1, or a temperature sensor, as described in 6.3.2.

3.1.19 *temperature reading, n*—the temperature obtained by a temperature measuring device or system that is equal to the thermometer reading described in 3.1.20.

3.1.19.1 *corrected temperature reading, n*—the temperature reading, as described in 3.1.19, corrected for barometric pressure.

3.1.20 *thermometer reading (or thermometer result), n*—the temperature of the saturated vapor measured in the neck of the flask below the vapor tube, as determined by the prescribed thermometer under the conditions of the test.

3.1.20.1 *corrected thermometer reading, n*—the thermometer reading, as described in 3.1.20, corrected for barometric pressure.

4. Summary of Test Method

4.1 Based on its composition, vapor pressure, expected IBP or expected EP, or combination thereof, the sample is placed in one of four groups. Apparatus arrangement, condenser temperature, and other operational variables are defined by the group in which the sample falls.

4.2 A 100-mL specimen of the sample is distilled under prescribed conditions for the group in which the sample falls. The distillation is performed in a laboratory batch distillation unit at ambient pressure under conditions that are designed to provide approximately one theoretical plate fractionation. Systematic observations of temperature readings and volumes of

condensate are made, depending on the needs of the user of the data. The volume of the residue and the losses are also recorded.

4.3 At the conclusion of the distillation, the observed vapor temperatures can be corrected for barometric pressure and the data are examined for conformance to procedural requirements, such as distillation rates. The test is repeated if any specified condition has not been met.

4.4 Test results are commonly expressed as percent evaporated or percent recovered versus corresponding temperature, either in a table or graphically, as a plot of the distillation curve.

5. Significance and Use

5.1 The basic test method of determining the boiling range of a petroleum product by performing a simple batch distillation has been in use as long as the petroleum industry has existed. It is one of the oldest test methods under the jurisdiction of ASTM Committee D02, dating from the time when it was still referred to as the Engler distillation. Since the test method has been in use for such an extended period, a tremendous number of historical data bases exist for estimating end-use sensitivity on products and processes.

5.2 The distillation (volatility) characteristics of hydrocarbons have an important effect on their safety and performance, especially in the case of fuels and solvents. The boiling range gives information on the composition, the properties, and the behavior of the fuel during storage and use. Volatility is the major determinant of the tendency of a hydrocarbon mixture to produce potentially explosive vapors.

5.3 The distillation characteristics are critically important for both automotive and aviation gasolines, affecting starting, warm-up, and tendency to vapor lock at high operating temperature or at high altitude, or both. The presence of high boiling point components in these and other fuels can significantly affect the degree of formation of solid combustion deposits.

5.4 Volatility, as it affects rate of evaporation, is an important factor in the application of many solvents, particularly those used in paints.

5.5 Distillation limits are often included in petroleum product specifications, in commercial contract agreements, process refinery/control applications, and for compliance to regulatory rules.

6. Apparatus

6.1 Basic Components of the Apparatus:

6.1.1 The basic components of the distillation unit are the distillation flask, the condenser and associated cooling bath, a metal shield or enclosure for the distillation flask, the heat source, the flask support, the temperature measuring device, and the receiving cylinder to collect the distillate.

6.1.2 Figs. 1 and 2 are examples of manual distillation units.

6.1.3 In addition to the basic components described in 6.1.1, automated units also are equipped with a system to measure and automatically record the temperature and the associated recovered volume in the receiving cylinder.

6.2 A detailed description of the apparatus is given in Annex A2.

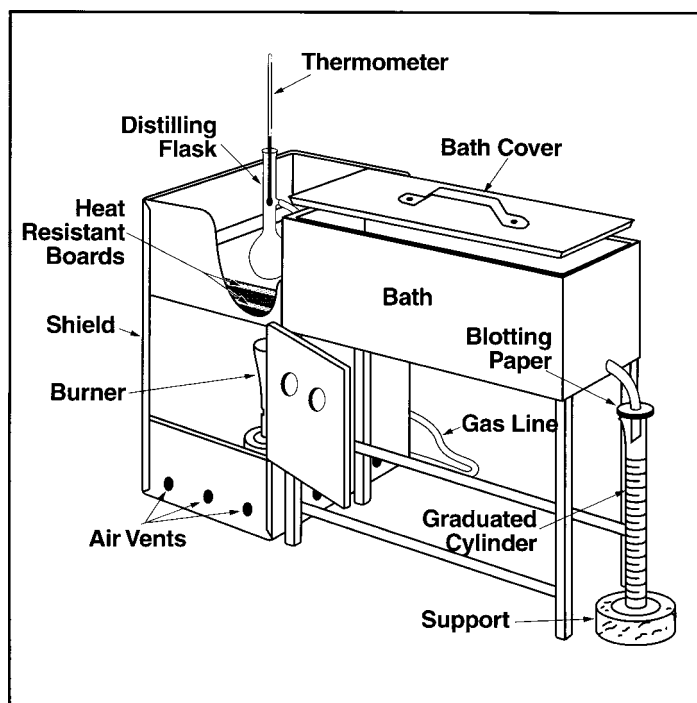

FIG. 1 Apparatus Assembly Using Gas Burner

6.3 Temperature Measuring Device:

6.3.1 Mercury-in-glass thermometers, if used, shall be filled with an inert gas, graduated on the stem and enamel backed. They shall conform to Specification E1 or IP Standard Methods for Analysis and Testing of Petroleum and Related Products 1996—Appendix A, or both, for thermometers ASTM 7C/IP 5C and ASTM 7F for the low range thermometers, and ASTM 8C/IP 6C and ASTM 8F for the high range thermometers.

6.3.1.1 Thermometers that have been exposed for an extended period above an observed temperature of 370°C shall not be reused without a verification of the ice point or checked as prescribed in Specification E1 and Test Method E77.

NOTE 2—At an observed thermometer reading of 370°C, the temperature of the bulb is approaching a critical range in the glass and the thermometer may lose its calibration.

6.3.2 Temperature measurement systems other than those described in 6.3.1 are satisfactory for this test method, provided that they exhibit the same temperature lag, emergent stem effect, and accuracy as the equivalent mercury-in-glass thermometer.

6.3.2.1 The electronic circuitry or the algorithms, or both, used shall include the capability to simulate the temperature lag of a mercury-in-glass thermometer.

6.3.2.2 Alternatively, the sensor can also be placed in a casing with the tip of the sensor covered so that the assembly, because of its adjusted thermal mass and conductivity, has a temperature lag time similar to that of a mercury-in-glass thermometer.

NOTE 3—In a region where the temperature is changing rapidly during the distillation, the temperature lag of a thermometer can be as much as 3 seconds.

6.3.3 In case of dispute, the referee test method shall be carried out with the specified mercury-in-glass thermometer.

6.4 Temperature Sensor Centering Device:

6.4.1 The temperature sensor shall be mounted through a snug-fitting device designed for mechanically centering the sensor in the neck of the flask without vapor leakage. Examples of acceptable centering devices are shown in Figs. 3 and 4. (Warning—The use of a plain stopper with a hole drilled through the center is not acceptable for the purpose described in 6.4.1.)

NOTE 4—Other centering devices are also acceptable, as long as they position and hold the temperature sensing device in the proper position in the neck of the distillation column, as shown in Fig. 5 and described in 10.5.

NOTE 5—When running the test by the manual method, products with a low IBP may have one or more readings obscured by the centering device. See also 10.14.3.1.

6.5 Automated equipment manufactured in 1999 and later shall be equipped with a device to automatically shut down power to the unit and to spray an inert gas or vapor in the chamber where the distillation flask is mounted in the event of fire.

NOTE 6—Some causes of fires are breakage of the distillation flask, electrical shorts, and foaming and spilling of liquid sample through the top opening of the flask.

6.6 Barometer—A pressure measuring device capable of measuring local station pressure with an accuracy of 0.1 kPa (1 mm Hg) or better, at the same elevation relative to sea level as the apparatus in the laboratory. (Warning—Do not take readings from ordinary aneroid barometers, such as those used at weather stations and airports, since these are precorrected to give sea level readings.)

7. Sampling, Storage, and Sample Conditioning

7.1 Determine the Group characteristics that correspond to the sample to be tested (see Table 2). Where the procedure is dependent upon the group, the section headings will be so marked.

7.2 Sampling:

7.2.1 Sampling shall be done in accordance with Practice D4057 or D4177 and as described in Table 3.

7.2.1.1 Group 1—Condition the sample container to below 10°C, preferably by filling the bottle with the cold liquid sample and discarding the first sample. If this is not possible because, for instance, the product to be sampled is at ambient temperature, the sample shall be drawn into a bottle prechilled to below 10°C, in such a manner that agitation is kept at a minimum. Close the bottle immediately with a tight-fitting closure. (Warning—Do not completely fill and tightly seal a cold bottle of sample because of the likelihood of breakage on warming.)

7.2.1.2 Groups 2, 3, and 4—Collect the sample at ambient temperature. After sampling, close the sample bottle immediately with a tight-fitting closure.

7.2.1.3 If the sample received by the testing laboratory has been sampled by others and it is not known whether sampling has been performed as described in 7.2, the sample shall be assumed to have been so sampled.

7.3 Sample Storage:

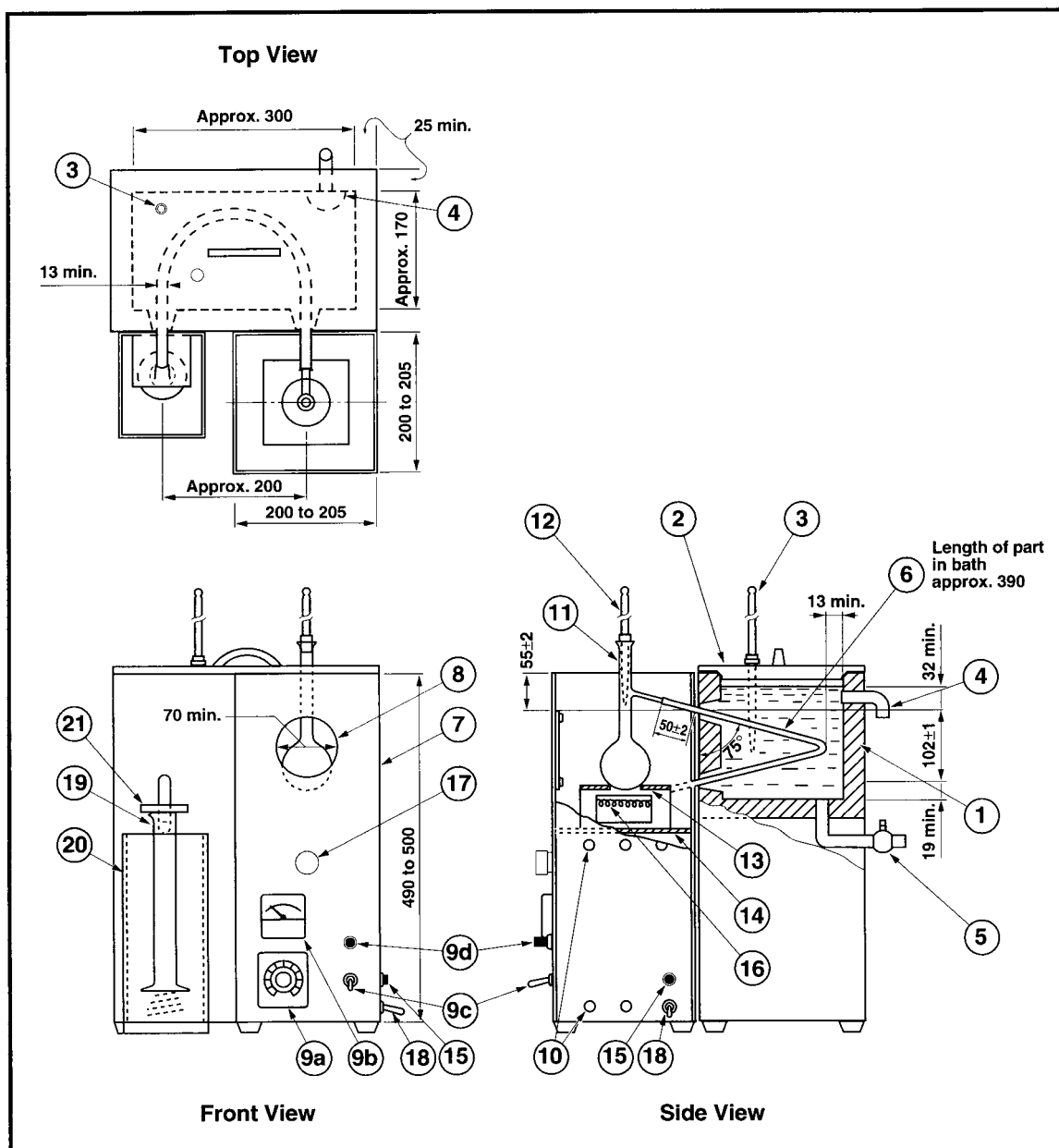

- | | |
|---------------------------|---|
| 1-Condenser bath | 11-Distillation flask |
| 2-Bath cover | 12-Temperature sensor |
| 3-Bath temperature sensor | 13-Flask support board |
| 4-Bath overflow | 14-Flask support platform |
| 5-Bath drain | 15-Ground connection |
| 6-Condenser tube | 16-Electric heater |
| 7-Shield | 17-Knob for adjusting level of support platform |
| 8-Viewing window | 18-Power source cord |
| 9a-Voltage regulator | 19-Receiver cylinder |
| 9b-Voltmeter or ammeter | 20-Receiver cooling bath |
| 9c-Power switch | 21-Receiver cover |
| 9d-Power light indicator | |
| 10-Vent | |

FIG. 2 Apparatus Assembly Using Electric Heater

TABLE 3 Sampling, Storage, and Sample Conditioning

		Group 1	Group 2	Group 3	Group 4
Temperature of sample bottle	°C	<10			
	°F	<50			
Temperature of stored sample	°C	<10 ^A	<10	ambient	ambient
	°F	<50 ^A	<50	ambient	ambient
Temperature of sample after conditioning prior to analysis	°C	<10 ^B	<10 ^B	Ambient or 9 to 21°C above pour point ^C	Ambient or Ambient or 48 to 70°F above pour point ^C
	°F	<50	<50	Ambient or 48 to 70°F above pour point ^C	Ambient or 48 to 70°F above pour point ^C
If sample is wet		resample	resample		
If resample is still wet ^D		dry in accordance with 7.5.2		dry in accordance with 7.5.3	

^A Under certain circumstances, samples can also be stored at temperatures below 20°C (68°F). See also 7.3.2 and 7.3.3.

^B If sample is to be immediately tested and is already at the temperature prescribed in Table 1, see 7.4.1.1.

^C If sample is (semi)-solid at ambient temperature, see also 10.3.1.1.

^D If sample is known to be wet, resampling may be omitted. Dry sample in accordance with 7.5.2 and 7.5.3.

NOTE 9—Suspended water in hazy samples in Groups 1 and 2 can be removed by the addition of anhydrous sodium sulfate and separating the liquid sample from the drying agent by decanting without statistically affecting the results of the test.⁵

7.5.3 *Groups 3 and 4*—In cases in which a water-free sample is not practical, the suspended water can be removed by shaking the sample with anhydrous sodium sulfate or other suitable drying agent and separating it from the drying agent by decanting. Note in the report that the sample has been dried by the addition of a desiccant.

8. Preparation of Apparatus

8.1 Refer to Table 1 and prepare the apparatus by choosing the appropriate distillation flask, temperature measuring device, and flask support board, as directed for the indicated group. Bring the temperature of the receiving cylinder, the flask, and the condenser bath to the indicated temperature.

8.2 Make any necessary provisions so that the temperature of the condenser bath and the receiving cylinder will be maintained at the required temperatures. The receiving cylinder shall be in a bath such that either the liquid level is at least as high as the 100-mL mark or the entire receiving cylinder is surrounded by an air circulation chamber.

8.2.1 *Groups 1, 2, and 3*—Suitable media for low temperature baths include, but are not limited to, chopped ice and water, refrigerated brine, and refrigerated ethylene glycol.

8.2.2 *Group 4*—Suitable media for ambient and higher bath temperatures include, but are not limited to, cold water, hot water, and heated ethylene glycol.

8.3 Remove any residual liquid in the condenser tube by swabbing with a piece of soft, lint-free cloth attached to a cord or wire.

9. Calibration and Standardization

9.1 *Temperature Measurement System*—Temperature measurement systems using other than the specified mercury-in-glass thermometers shall exhibit the same temperature lag, emergent stem effect, and accuracy as the equivalent mercury-in-glass thermometer. Confirmation of the calibration of these

temperature measuring systems shall be made at intervals of not more than six months, and after the system has been replaced or repaired.

9.1.1 The accuracy and the calibration of the electronic circuitry or computer algorithms, or both, shall be verified by the use of a standard precision resistance bench. When performing this verification, no algorithms shall be used to correct the temperature for lag and the emergent stem effect (see manufacturer's instructions).

9.1.2 Verification of the calibration of temperature measuring devices shall be conducted by distilling toluene in accordance with Group 1 of this test method and comparing the 50 % recovered temperature with that shown in Table 4.⁶

9.1.2.1 If the temperature reading is not within the values shown in Table 4 for the respective apparatus being used (see Note 11 and Table 4), the temperature measurement system shall be considered defective and shall not be used for the test.

NOTE 10—Toluene is used as a verification fluid for calibration; it will yield almost no information on how well an electronic measurement system simulates the temperature lag of a liquid-in-glass thermometer.

9.1.2.2 Reagent grade toluene and hexadecane (cetane), conforming to the specifications of the Committee on Analytical Reagents of the American Chemical Society,⁷ shall be used. However, other grades may also be used, provided it is first ascertained that the reagent is of sufficient purity to permit its use without lessening the accuracy of the determination.

NOTE 11—At 101.3 kPa, toluene is shown in reference manuals as boiling at 110.6°C when measured using a partial immersion thermometer. Because this test method uses thermometers calibrated for total immersion, the results typically will be lower and, depending on the thermometer and the situation, may be different for each thermometer. At 101.3 kPa, hexadecane is shown in reference manuals as boiling at 287.0°C when measured using a partial immersion thermometer. Because this test method uses thermometers calibrated for total immersion, the results typically will be lower, and, depending on the thermometer and the

⁶ Supporting data have been filed at ASTM International Headquarters and may be obtained by requesting Research Report RR:D02-1580.

⁷ *Reagent Chemicals, American Chemical Society Specifications*, American Chemical Society, Washington, DC. For Suggestions on the testing of reagents not listed by the American Chemical Society, see *Annual Standards for Laboratory Chemicals*, BDH Ltd., Poole, Dorset, U.K., and the *United States Pharmacopeia and National Formulary*, U.S. Pharmacopeial Convention, Inc. (USPC), Rockville, MD.

⁵ Supporting data have been filed at ASTM International Headquarters and may be obtained by requesting Research Report RR:D02-1455.

TABLE 4 True and Min and Max D86 50 % Recovered Boiling Points (°C)^A

		Manual		Automated	
		Distillation conditions min D86 50 % boiling point	Distillation conditions max D86 50 % boiling point	Distillation conditions min D86 50 % boiling point	Distillation conditions max D86 50 % boiling point
Toluene	ASTM/IP true boiling point	Group 1, 2, and 3	Group 1, 2, and 3	Group 1, 2, and 3	Group 1, 2, and 3
	110.6	105.9	111.8	108.5	109.7
Hexadecane	ASTM/IP true boiling point	Group 4	Group 4	Group 4	Group 4
	287.0	272.2	283.1	277.0	280.0

^A The manual and automated temperatures show in this table are the values for the 95 % tolerance interval for the 99 % population coverage. The proposed tolerance is approximately $3 \times \text{sigma}$. Information on the values in this table can be found in RR:D02-1580.

situation, may be different for each thermometer.

9.1.3 A procedure to determine the magnitude of the temperature lag is described in [Annex A3](#).

9.1.4 A procedure to emulate the emergent stem effect is described in [Appendix X4](#).

9.1.5 To verify the calibration of the temperature measurement system at elevated temperatures, use hexadecane. The temperature measurement system shall indicate, at 50% recovered, a temperature comparable to that shown in [Table 4](#) for the respective apparatus under Group 4 distillation conditions.

NOTE 12—Because of the high melting point of hexadecane, Group 4 verification distillations will have to be carried out with condenser temperatures $>20^{\circ}\text{C}$.

9.2 Automated Method:

9.2.1 *Level Follower*—For an automated distillation apparatus, the level follower/recording mechanism of the apparatus shall have a resolution of 0.1 volume % or better with a maximum error of 0.3 volume % between the 5 and 100 volume % points. The calibration of the assembly shall be verified in accordance with manufacturer’s instructions at intervals of not more than three months and after the system has been replaced or repaired.

NOTE 13—The typical calibration procedure involves verifying the output with the receiver containing 5 and 100 volume % of material respectively.

9.2.2 *Barometric Pressure*—At intervals of not more than six months, and after the system has been replaced or repaired, the barometric reading of the instrument shall be verified against a barometer, as described in [6.6](#).

10. Procedure

10.1 Record the prevailing barometric pressure.

10.2 *Groups 1 and 2*—Ensure that the sample is conditioned in accordance with [Table 3](#). Fit a low range thermometer provided with a snug-fitting cork or stopper of silicone rubber, or equivalent polymeric material, tightly into the neck of the sample container and bring the temperature of the sample to the temperature indicated in [Table 1](#).

10.3 *Groups 1, 2, 3, and 4*—Check that the temperature of the sample is as shown in [Table 1](#). Pour the specimen precisely to the 100-mL mark of the receiving cylinder, and transfer the

contents of the receiving cylinder as completely as practical into the distillation flask, ensuring that none of the liquid flows into the vapor tube.

NOTE 14—It is important that the difference between the temperature of the specimen and the temperature of the bath around the receiving cylinder is as small as practically possible. A difference of 5°C can make a difference of 0.7 mL.

10.3.1 *Groups 3 and 4*—If the sample is not fluid at ambient temperature, it is to be heated to a temperature between 9 and 21°C above its pour point (Test Methods [D97](#), [D5949](#), [D5950](#), or [D5985](#)) prior to analysis. If the sample has partially or completely solidified in the intervening period, it shall be vigorously shaken after melting, and prior to sampling, to ensure homogeneity.

10.3.1.1 If the sample is not fluid at ambient temperatures, disregard the temperature range shown in [Table 1](#) for the receiving cylinder and sample. Prior to analysis, heat the receiving cylinder to approximately the same temperature as the sample. Pour the heated specimen precisely to the 100-mL mark of the receiving cylinder, and transfer the contents of the receiving cylinder as completely as practical into the distillation flask, ensuring that none of the liquid flows into the vapor tube.

NOTE 15—Any material that evaporates during the transfer will contribute to the loss; any material that remains in the receiving cylinder will contribute to the observed recovery volume at the time of the IBP.

10.4 If the sample can be expected to demonstrate irregular boiling behavior, that is, bumping, add a few boiling chips to the specimen. The addition of a few boiling chips is acceptable for any distillation.

10.5 Fit the temperature sensor through a snug-fitting device, as described in [6.4](#), to mechanically center the sensor in the neck of the flask. In the case of a thermometer, the bulb is centered in the neck and the lower end of the capillary is level with the highest point on the bottom of the inner wall of the vapor tube (see [Fig. 5](#)). In the case of a thermocouple or resistance thermometer, follow the manufacturer’s instructions as to placement (see [Fig. 6](#)).

NOTE 16—If vacuum grease is used on the mating surface of the centering device, use the minimum amount of grease that is practical.

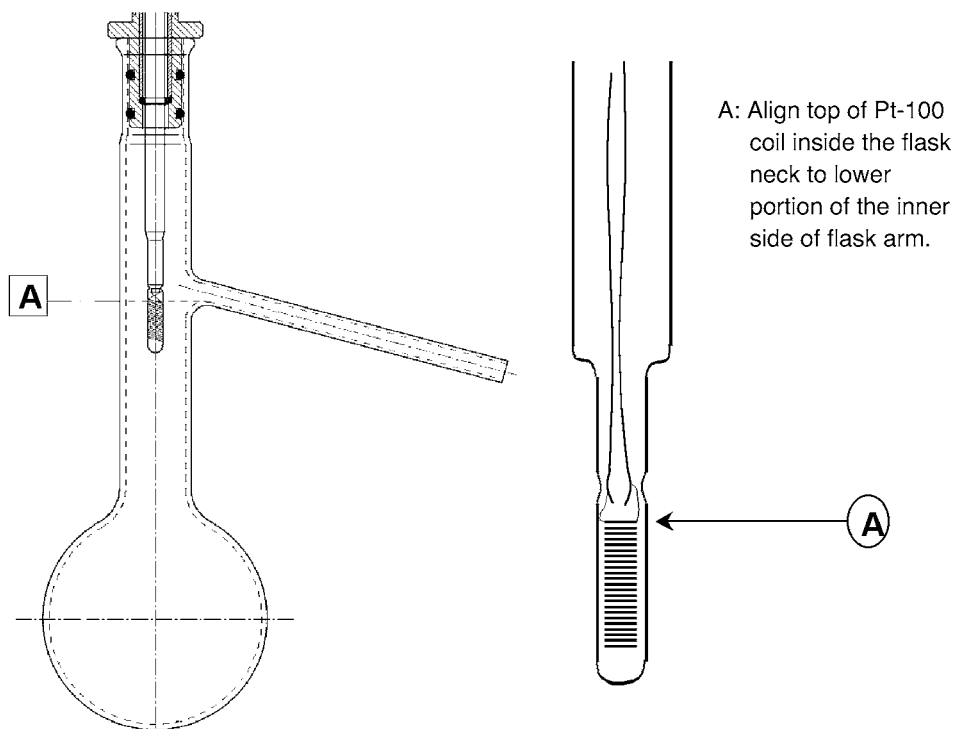

FIG. 6 Example of One Manufacturer's Recommended Placement of Pt-100 Probe Relative to Distillation Flask Sidearm for Automated D86 Distillation Instrument

10.6 Fit the flask vapor tube, provided with a snug-fitting cork or rubber stopper of silicone, or equivalent polymeric material, tightly into the condenser tube. Adjust the flask in a vertical position so that the vapor tube extends into the condenser tube for a distance from 25 to 50 mm. Raise and adjust the flask support board to fit it snugly against the bottom of the flask.

10.7 Place the receiving cylinder that was used to measure the specimen, without drying the inside of the cylinder, into its temperature-controlled bath under the lower end of the condenser tube. The end of the condenser tube shall be centered in the receiving cylinder and shall extend therein for a distance of at least 25 mm, but not below the 100-mL mark.

10.8 Initial Boiling Point:

10.8.1 Manual Method—To reduce evaporation loss of the distillate, cover the receiving cylinder with a piece of blotting paper, or similar material, that has been cut to fit the condenser tube snugly. If a receiver deflector is being used, start the distillation with the tip of the deflector just touching the wall of the receiving cylinder. If a receiver deflector is not used, keep the drip tip of the condenser away from the wall of the receiving cylinder. Note the start time. Observe and record the IBP to the nearest 0.5°C (1.0°F). If a receiver deflector is not being used, immediately move the receiving cylinder so that the tip of the condenser touches its inner wall.

10.8.2 Automated Method—To reduce evaporation loss of the distillate, use the device provided by the instrument manufacturer for this purpose. Apply heat to the distillation flask and contents with the tip of the receiver deflector just touching the wall of the receiving cylinder. Note the start time. Record the IBP to the nearest 0.1°C (0.2°F).

10.9 Regulate the heating so that the time interval between the first application of heat and the IBP is as specified in Table 5.

10.10 Regulate the heating so that the time from IBP to 5 % recovered is as indicated in Table 5.

10.11 Continue to regulate the heating so that the uniform average rate of condensation from 5 % recovered to 5 mL residue in the flask is 4 to 5 mL per min. (**Warning**—Due to the configuration of the boiling flask and the conditions of the test, the vapor and liquid around the temperature sensor are not in thermodynamic equilibrium. The distillation rate will consequently have an effect on the measured vapor temperature. The distillation rate shall, therefore, be kept as constant as possible throughout the test.)

NOTE 17—When testing gasoline samples, it is not uncommon to see the condensate suddenly form non-miscible liquid phases and bead up on the temperature measuring device and in the neck of the boiling flask at a vapor temperature of around 160°C. This may be accompanied by a sharp (about 3°C) dip in the vapor temperature and a drop in the recovery rate. The phenomenon, which may be due to the presence of trace water in the sample, may last for 10 to 30 s before the temperature recovers and the condensate starts flowing smoothly again. This point is sometimes colloquially referred to as the Hesitation Point.

10.12 Repeat any distillation that did not meet the requirements described in 10.9, 10.10, and 10.11.

10.13 If a decomposition point, as described in 3.1.3, is observed, discontinue the heating and proceed as directed in 10.17.

10.14 In the interval between the IBP and the end of the distillation, observe and record data necessary for the calculation and reporting of the results of the test as required by the

TABLE 5 Conditions During Test Procedure

		Group 1	Group 2	Group 3	Group 4
Temperature of cooling bath ^A	°C	0–1	0–5	0–5	0–60
	°F	32–34	32–40	32–40	32–140
Temperature of bath around receiving cylinder	°C	13–18	13–18	13–18	±3
	°F	55–65	55–65	55–65	±5 of charge temperature
Time from first application of heat to initial boiling point, min		5–10	5–10	5–10	5–15
Time from initial boiling point to 5 % recovered, s		60–100	60–100		
Uniform average rate of condensation from 5 % recovered to 5 mL in flask, mL/min		4–5	4–5	4–5	4–5
Time recorded from 5 mL residue to end point, min		5 max	5 max	5 max	5 max

^A the proper condenser bath temperature will depend upon the wax content of the sample and of its distillation fractions. The test is generally performed using one single condenser temperature. Wax formation in the condenser can be deduced from (a) the presence of wax particles in the distillate coming off the drip tip, (b) a higher distillation loss than what would be expected based on the initial boiling point of the specimen, (c) an erratic recovery rate and (d) the presence of wax particles during the removal of residual liquid by swabbing with a lint-free cloth (see 8.3). The minimum temperature that permits satisfactory operation shall be used. In general, a bath temperature in the 0 to 4°C range is suitable for kerosine, Grade No. 1 fuel oil and Grade No. 1-D diesel fuel oil. In some cases involving Grade No. 2 fuel oil, Grade No. 2-D diesel fuel oil, gas oils and similar distillates, it may be necessary to hold the condenser bath temperature in the 38 to 60°C range.

specification involved, or as previously established for the sample under test. These observed data can include temperature readings at prescribed percentages recovered or percentages recovered at prescribed temperature readings, or both.

10.14.1 *Manual Method*—Record all volumes in the graduated cylinder to the nearest 0.5 mL, and all temperature readings to the nearest 0.5°C (1.0°F).

10.14.2 *Automated Method*—Record all volumes in the receiving cylinder to the nearest 0.1 mL, and all temperature readings to the nearest 0.1°C (0.2°F).

10.14.3 *Group 1, 2, 3, and 4*—In cases in which no specific data requirements have been indicated, record the IBP and the EP (FBP) or the dry point, or both, and temperature readings at 5, 15, 85, and 95 % recovered, and at each 10 % multiple of volume recovered from 10 to 90, inclusive.

10.14.3.1 *Group 4*—When a high range thermometer is used in testing aviation turbine fuels and similar products, pertinent thermometer readings can be obscured by the centering device. If these readings are required, perform a second distillation in accordance with Group 3. In such cases, reading from a low range thermometer can be reported in place of the obscured high range thermometer readings, and the test report shall so indicate. If, by agreement, the obscured readings are waived, the test report shall so indicate.

10.14.4 When it is required to report the temperature reading at a prescribed percent evaporated or recovered for a sample that has a rapidly changing slope of the distillation curve in the region of the prescribed percent evaporated or recovered reading, record temperature readings at every 1 % recovered. The slope is considered rapidly changing if the change in slope (C) of the data points described in 10.14.2 in that particular area is greater than 0.6 (change of slope (F) is greater than 1.0) as calculated by Eq 1 (Eq 2).

$$\text{Change of Slope } (C) = \frac{(C_2 - C_1)/(V_2 - V_1) - (C_3 - C_2)/(V_3 - V_2)}{(1)}$$

$$\text{Change of Slope } (F) = \frac{(F_2 - F_1)/(V_2 - V_1) - (F_3 - F_2)/(V_3 - V_2)}{(2)}$$

where:

C_1 = temperature at the volume % recorded one reading prior to the volume % in question, °C,

C_2 = temperature at the volume % recorded in question, °C,

C_3 = temperature at the volume % recorded following the volume % in question, °C,

F_1 = temperature at the volume % recorded one reading prior to the volume % in question, °F,

F_2 = temperature at the volume % recorded in question, °F,

F_3 = temperature at the volume % recorded following the volume % in question, °F,

V_1 = volume % recorded one reading prior to the volume % in question,

V_2 = volume % recorded at the volume % in question, and

V_3 = volume % recorded following the volume % in question.

10.15 When the residual liquid in the flask is approximately 5 mL, make a final adjustment of the heat. The time from the 5 mL of liquid residue in the flask to the EP (FBP) shall be within the limits prescribed in Table 5. If this condition is not satisfied, repeat the test with appropriate modification of the final heat adjustment.

NOTE 18—Since it is difficult to determine when there is 5 mL of boiling liquid left in the flask, this time is determined by observing the amount of liquid recovered in the receiving cylinder. The dynamic holdup has been determined to be approximately 1.6 mL at this point. If there are no front end losses, the amount of 5 mL in the flask can be assumed to correspond with an amount of 93.5 mL in the receiving cylinder. This amount has to be adjusted for the estimated amount of front end loss.

10.15.1 If the actual front end loss differs more than 2 mL from the estimated value, the test shall be rerun.

10.16 Observe and record the EP (FBP) or the dry point, or both, as required, and discontinue the heating.

NOTE 19—Groups 1 and 2, once the final heat adjustment is made, the vapor temperature/thermometer reading will continue to increase. As the distillation nears the end point (final boiling point) the distillation typically achieves dry point first. After the dry point has been achieved the vapor temperature/thermometer reading should continue to increase. The bottom

of the flask will be dry but the sides and neck of the flask and the temperature sensor will still have vapor condensate present. The vapor condensate may have the appearance of a white cloud of fumes. This vapor condensate/cloud of fumes should totally engulf the temperature-measuring sensor before the vapor temperature starts to decrease. If these observations do not occur, the end point may not have been reached. It would be advisable to repeat the test adding additional heat to the final heat adjustment. Typically the vapor temperature will continue to rise as the dry point is reached and the vapor cloud engulfs the temperature-measuring sensor. When the end point is near, the rate of temperature increase will slow and level off. Once the endpoint is reached the vapor temperature will start and continue to decrease. If the vapor temperature starts to decrease but then increases and repeats this cycle while the vapor temperature continues to increase you have added too much heat to the final heat adjustment. If this is the case, it would be advisable to repeat the test lowering final heat setting.

Groups 3 and 4, many Group 3 and 4 samples will have the same distillation characteristics in regards to dry point and endpoint as Groups 1 and 2. With samples that contain higher temperature boiling materials it may not be possible to detect a dry point or an end point before the decomposition point occurs.

10.17 Allow the distillate to drain into the receiving cylinder, after heating has been discontinued.

10.17.1 *Manual Method*—While the condenser tube continues to drain into the graduated cylinder, observe and note the volume of condensate to the nearest 0.5 mL at 2 min intervals until two successive observations agree. Measure the volume in the receiving cylinder accurately, and record it to the nearest 0.5 mL.

10.17.2 *Automated Method*—The apparatus shall continually monitor the recovered volume until this volume changes by no more than 0.1 mL in 2 min. Record the volume in the receiving cylinder accurately to the nearest 0.1 mL.

10.18 Record the volume in the receiving cylinder as percent recovery. If the distillation was previously discontinued under the conditions of a decomposition point, deduct the percent recovered from 100, report this difference as the sum of percent residue and percent loss, and omit the procedure given in 10.19.

10.19 After the flask has cooled and no more vapor is observed, disconnect the flask from the condenser, pour its contents into a 5-mL graduated cylinder, and with the flask suspended over the cylinder, allow the flask to drain until no appreciable increase in the volume of liquid in the cylinder is observed. Measure the volume in the graduated cylinder to the nearest 0.1 mL, and record as percent residue.

10.19.1 If the 5-mL graduated cylinder does not have graduations below 1 mL and the volume of liquid is less than 1 mL, prefill the cylinder with 1 mL of a heavy oil to allow a better estimate of the volume of the material recovered.

10.19.1.1 If a residue greater than expected is obtained, and the distillation was not purposely terminated before the EP, check whether adequate heat was applied towards the end of the distillation and whether conditions during the test conformed to those specified in Table 5. If not, repeat test.

NOTE 20—The distillation residues of this test method for gasoline, kerosene, and distillate diesel are typically 0.9–1.2, 0.9–1.3, and 1.0–1.4 volume %, respectively.

NOTE 21—The test method is not designed for the analysis of distillate fuels containing appreciable quantities of residual material (see 1.2).

TABLE 6 Approximate Thermometer Reading Correction

Temperature Range		Correction ^A per 1.3 kPa (10 mm Hg) Difference in Pressure	
°C	°F	°C	°F
10–30	50–86	0.35	0.63
30–50	86–122	0.38	0.68
50–70	122–158	0.40	0.72
70–90	158–194	0.42	0.76
90–110	194–230	0.45	0.81
110–130	230–266	0.47	0.85
130–150	266–302	0.50	0.89
150–170	302–338	0.52	0.94
170–190	338–374	0.54	0.98
190–210	374–410	0.57	1.02
210–230	410–446	0.59	1.07
230–250	446–482	0.62	1.11
250–270	482–518	0.64	1.15
270–290	518–554	0.66	1.20
290–310	554–590	0.69	1.24
310–330	590–626	0.71	1.28
330–350	626–662	0.74	1.33
350–370	662–698	0.76	1.37
370–390	698–734	0.78	1.41
390–410	734–770	0.81	1.46

^A Values to be added when barometric pressure is below 101.3 kPa (760 mm Hg) and to be subtracted when barometric pressure is above 101.3 kPa.

10.19.2 *Groups 1, 2, 3, and 4*—Record the volume in the 5-mL graduated cylinder, to the nearest 0.1 mL, as percent residue.

10.20 If the intent of the distillation is to determine the percent evaporated or percent recovered at a predetermined corrected temperature reading, modify the procedure to conform to the instructions described in Annex A4.

10.21 Examine the condenser tube and the side arm of the flask for waxy or solid deposits. If found, repeat the test after making adjustments described in Footnote A of Table 5.

11. Calculations

11.1 The percent total recovery is the sum of the percent recovery (see 10.18) and the percent residue (see 10.19). Deduct the percent total recovery from 100 to obtain the percent loss.

11.2 Do not correct the barometric pressure for meniscus depression, and do not adjust the pressure to what it would be at sea level.

NOTE 22—The observed barometric reading does not have to be corrected to a standard temperature and to standard gravity. Even without performing these corrections, the corrected temperature readings for the same sample between laboratories at two different locations in the world will, in general, differ less than 0.1°C at 100°C. Almost all data obtained earlier have been reported at barometric pressures that have not been corrected to standard temperature and to standard gravity.

11.3 Correct temperature readings to 101.3 kPa (760 mm Hg) pressure. Obtain the correction to be applied to each temperature reading by means of the Sydney Young equation as given in Eq 3, Eq 4, or Eq 5, as appropriate, or by the use of Table 6. For Celsius temperatures:

$$C_c = 0.0009 (101.3 - P_k) (273 + t_c) \quad (3)$$

$$C_c = 0.00012 (760 - P) (273 + t_c) \quad (4)$$

For Fahrenheit temperatures:

$$C_f = 0.00012 (760 - P) (460 + t_f) \quad (5)$$

where:

- t_c = the observed temperature reading in °C,
- t_f = the observed temperature reading in °F,
- C_c and C_f = corrections to be added algebraically to the observed temperature readings,
- P_k = barometric pressure, prevailing at the time and location of the test, kPa, and
- P = barometric pressure, prevailing at the time and location of the test, mm Hg.

After applying the corrections and rounding each result to the nearest 0.5°C (1.0°F) or 0.1°C (0.2°F), as appropriate to the apparatus being used, use the corrected temperature readings in all further calculations and reporting.

NOTE 23—Temperature readings are not corrected to 101.3 kPa (760 mm Hg) when product definitions, specifications, or agreements between the parties involved indicate, specifically, that such correction is not required or that correction shall be made to some other base pressure.

11.4 Correct the actual loss to 101.3 kPa (760 mm Hg) pressure when temperature readings are corrected to 101.3 kPa pressure. The corrected loss, L_c , is calculated from Eq 6 or Eq 7, as appropriate, or can be read from the tables presented as Fig. X3.1 or Fig. X3.2.

$$L_c = 0.5 + (L - 0.5) / \{1 + (101.3 - P_k) / 8.00\} \quad (6)$$

$$L_c = 0.5 + (L - 0.5) / \{1 + (760 - P) / 60.0\} \quad (7)$$

where:

- L = observed loss,
- L_c = corrected loss,
- P_k = pressure, kPa, and
- P = pressure, mm Hg.

NOTE 24—Eq 6 and 7 above have been derived from the data in Table A4.3 and Eqs 5 and 6 in Test Method D86 – 95 and earlier versions. It is probable that Eq 6 and 7 shown were the original empirical equations from which the table and equations in the Test Method D86 – 95 and earlier versions were derived.

11.4.1 Calculate the corresponding corrected percent recovery in accordance with the following equation:

$$R_c = R + (L - L_c) \quad (8)$$

where:

- L = percent loss or observed loss,
- L_c = corrected loss,
- R = percent recovery, and
- R_c = corrected percent recovery.

11.5 To obtain the percent evaporated at a prescribed temperature reading, add the percent loss to each of the observed percent recovered at the prescribed temperature readings, and report these results as the respective percent evaporated, that is:

$$P_e = P_r + L \quad (9)$$

where:

- L = observed loss,
- P_e = percent evaporated, and
- P_r = percent recovered.

11.6 To obtain temperature readings at prescribed percent evaporated, and if no recorded temperature data is available within 0.1 volume % of the prescribed percent evaporated, use either of the two following procedures, and indicate on the

report whether the arithmetical procedure or the graphical procedure has been used.

11.6.1 *Arithmetical Procedure*—Deduct the observed loss from each prescribed percent evaporated to obtain the corresponding percent recovered. Calculate each required temperature reading as follows:

$$T = T_L + (T_H - T_L) (R - R_L) / (R_H - R_L) \quad (10)$$

where:

- R = percent recovered corresponding to the prescribed percent evaporated,
- R_H = percent recovered adjacent to, and higher than R ,
- R_L = percent recovered adjacent to, and lower than R ,
- T = temperature reading at the prescribed percent evaporated,
- T_H = temperature reading recorded at R_H , and
- T_L = temperature reading recorded at R_L .

Values obtained by the arithmetical procedure are affected by the extent to which the distillation graphs are nonlinear. Intervals between successive data points can, at any stage of the test, be no wider than the intervals indicated in 10.18. In no case shall a calculation be made that involves extrapolation.

11.6.2 *Graphical Procedure*—Using graph paper with uniform subdivisions, plot each temperature reading corrected for barometric pressure, if required (see 11.3), against its corresponding percent recovered. Plot the IBP at 0 % recovered. Draw a smooth curve connecting the points. For each prescribed percent evaporated, deduct the distillation loss to obtain the corresponding percent recovered and take from the graph the temperature reading that this percent recovered indicates. Values obtained by graphical interpolation procedures are affected by the care with which the plot is made.

NOTE 25—See Appendix X1 for numerical examples illustrating the arithmetical procedure.

11.6.3 In most automated instruments, temperature-volume data are collected at 0.1 volume % intervals or less and stored in memory. To report a temperature reading at a prescribed percent evaporated, neither of the procedures described in 11.6.1 and 11.6.2 have to be used. Obtain the desired temperature directly from the database as the temperature closest to and within 0.1 volume % of the prescribed percent evaporated.

12. Report

12.1 Report the following information (see Appendix X5 for examples of reports):

12.2 Report the barometric pressure to the nearest 0.1 kPa (1 mm Hg).

12.3 Report all volumetric readings in percentages.

12.3.1 *Manual Method*—Report volumetric readings to the nearest 0.5, and all temperature readings to the nearest 0.5°C (1.0°F).

12.3.2 *Automated Method*—Report volumetric readings to the nearest 0.1, and all temperature readings to the nearest one tenth degree.

12.4 After barometric corrections of the temperature readings have been made, the following data require no further calculation prior to reporting: IBP, dry point, EP (FBP),

decomposition point, and all pairs of corresponding values involving percent recovered and temperature readings.

12.4.1 The report shall state if the temperature readings have not been corrected for barometric pressure.

12.5 When the temperature readings have not been corrected to 101.3 kPa (760 mm Hg) pressure, report the percent residue and percent loss as *observed* in accordance with 10.19 and 11.1, respectively.

12.6 Do not use the corrected loss in the calculation of percent evaporated.

12.7 It is advisable to base the report on relationships between temperature readings and percent evaporated when the sample is a gasoline, or any other product classified under Group 1, or in which the percent loss is greater than 2.0. Otherwise, the report can be based on relationships between temperature readings and percent evaporated or percent recovered. Every report must indicate clearly which basis has been used.

12.7.1 In the manual method, if results are given in percent evaporated versus temperature readings, report if the arithmetical or the graphical procedure was used (see 11.6).

12.8 Report if a drying agent, as described in 7.5.2 or 7.5.3, was used.

12.9 Fig. X1.1 is an example of a tabular report. It shows the percent recovered versus the corresponding temperature reading and versus the corrected temperature reading. It also shows the percent loss, the corrected loss, and the percent evaporated versus the corrected temperature reading.

13. Precision and Bias

13.1 *Precision*—The precision of this test method, as determined by the statistical examination of the interlaboratory test results,⁸ is as follows:

NOTE 26—The precision and bias have been derived according to the group number in the following fashion. Group 1, 2, and 3 samples are labeled as NOT4, and Group 4 samples are labeled GRP4.

NOTE 27—The precision was derived from data produced by automated D86 apparatus. Typical examples of precision for manual apparatus can be calculated from the information contained in Annex A4 (see A4.10).

NOTE 28—Information on the precision of % evaporated or % recovered at a prescribed temperature can be found in Annex A4.

NOTE 29—A new interlaboratory study is being planned to address concerns that laboratories are not able to meet the precision for percent evaporated temperature at fifty percent.

13.1.1 *Repeatability*—The difference between successive test results, obtained by the same operator using the same apparatus under constant operating conditions on identical test material, would in the long run, in the normal and correct operation of this test method, exceed the following only in one case in twenty.

NOT4: Refer to Annex A1 for tables of calculated repeatability.	
IBP: $r = 0.0295(E + 51.19)$	valid range: 20 – 70°C
E10: $r = 1.33$	valid range: 35 – 95°C
E50: $r = 0.74$	valid range: 65 – 220°C
E90: $r = 0.00755(E + 59.77)$	valid range: 110 – 245°C
FBP: $r = 3.33$	valid range: 135 – 260°C

GRP4: Refer to Annex A1 for tables of calculated repeatability.	
IBP: $r = 0.018T$	valid range: 145 – 220°C
T10: $r = 0.0094T$	valid range: 160 – 265°C
T50: $r = 0.94$	valid range: 170 – 295°C
T90: $r = 0.0041T$	valid range: 180 – 340°C
T95: $r = 0.01515(T-140)$	valid range: 260 – 340°C (Diesel)
FBP: $r = 2.2$	valid range: 195 – 365°C

where:

E = evaporated temperature within valid range prescribed, and

T = recovered temperature within valid range prescribed.

NOTE 30—For naphthas, solvents and other similar materials where percent recovered are reported and the percent loss is typically less than one percent, the percent recovered temperatures can be considered identical to the percent evaporated temperatures and precision can be calculated as shown for NOT4.

13.1.2 *Reproducibility*—The difference between two single and independent test results, obtained by different operators working in different laboratories on identical test material, would in the long run, in normal and correct operation of this test method, exceed the following only in one case in twenty.

NOT4: Refer to Annex A1 for tables of calculated reproducibility.	
IBP: $R = 0.0595(E + 51.19)$	valid range: 20 – 70°C
E10: $R = 3.20$	valid range: 35 – 95°C
E50: $R = 1.88$	valid range: 65 – 220°C
E90: $R = 0.019(E + 59.77)$	valid range: 110 – 245°C
FBP: $R = 6.78$	valid range: 135 – 260°C

GRP4: Refer to Annex A1 for tables of calculated reproducibility.	
IBP: $R = 0.055T$	valid range: 145 – 220°C
T10: $R = 0.022T$	valid range: 160 – 265°C
T50: $R = 2.97$	valid range: 170 – 295°C
T90: $R = 0.015T$	valid range: 180 – 340°C
T95: $R = 0.0423(T-140)$	valid range: 260 – 340°C (Diesel)
FBP: $R = 7.1$	valid range: 195 – 365°C

where:

E = evaporated temperature within valid range prescribed, and

T = recovered temperature within valid range prescribed.

NOTE 31—For naphthas, solvents and other similar materials where percent recovered are reported and the percent loss is typically less than one percent, the percent recovered temperatures can be considered identical to the percent evaporated temperatures and precision can be calculated as shown for NOT4.

13.2 The precision statements were derived according to Practice D6300 from a 2005 interlaboratory cooperative test program.⁸ Sixteen laboratories participated and analyzed thirty three sample sets comprised of; specification grade gasolines, some containing up to 10 % ethanol, specification grade diesel, with a B5 and B20 biodiesel, specification grade heating oil, aviation turbine fuels, aviation gasolines, marine fuels, mineral spirits and toluene. The temperature range covered was 23 to 365°C. Information on the type of samples and their average boiling points are in the research report.

NOTE 32—The precision was not determined for one sample of gasoline with high vapor pressure which exhibited high loss, and one sample of aviation turbine fuel doped with gasoline, which is atypical.

13.3 Bias:

13.3.1 *Bias*—Since there is no accepted reference material suitable for determining the bias for the procedure in these test methods, bias has not been determined.

⁸ Supporting data (results of the 2005 Interlaboratory Cooperative Test Program) have been filed at ASTM International Headquarters and may be obtained by requesting Research Report RR:D02-1621.

13.3.2 *Relative Bias between Manual and Automated Apparatus*—An interlaboratory study⁶ conducted in 2003 using manual and automated apparatus has concluded that there is no statistical evidence to suggest that there is a bias between manual and automated results.

14. Keywords

14.1 batch distillation; distillates; distillation; laboratory distillation; petroleum products

ANNEXES

(Mandatory Information)

A1. PRECISION TABLES FOR REPEATABILITY (r) AND REPRODUCIBILITY (R)

A1.1 Tables:

Evaporated IBP Temperature (°C)	r_D86auto	IBP_NOT4 R_D86auto	205	1.93	4.51
20	2.10	4.24	210	1.97	4.62
25	2.25	4.53	215	2.02	4.73
30	2.40	4.83	220	2.07	4.84
35	2.54	5.13	225	2.12	4.95
40	2.69	5.43	230	2.16	5.06
45	2.84	5.72	235	2.21	5.17
50	2.99	6.02	240	2.26	5.28
55	3.13	6.32	245	2.30	5.39
60	3.28	6.62	250	2.35	5.50
65	3.43	6.91	255	2.40	5.61
70	3.58	7.21	260	2.44	5.72
			265	2.49	5.83
Recovered IBP Temperature (°C)	r_D86auto	IBP_GRP4 R_D86auto	Evaporated 50 % Temperature (°C) 65–220	r_D86auto	E50_NOT4 R_D86auto
145	2.61	7.98	Recovered 50 % Temperature (°C) 170–295	0.74	1.88
150	2.70	8.25	Evaporated 90% Temperature (°C)	r_D86auto	T50_GRP4 R_D86auto
155	2.79	8.53	110	0.94	2.97
160	2.88	8.80	115	r_D86auto	E90_NOT4 R_D86auto
165	2.97	9.08	120	1.28	3.23
170	3.06	9.35	125	1.32	3.32
175	3.15	9.63	130	1.36	3.42
180	3.24	9.90	135	1.40	3.51
185	3.33	10.18	140	1.43	3.61
190	3.42	10.45	145	1.47	3.70
195	3.51	10.73	150	1.51	3.80
200	3.60	11.00	155	1.55	3.89
205	3.69	11.28	160	1.58	3.99
210	3.78	11.55	165	1.62	4.08
215	3.87	11.83	170	1.66	4.18
220	3.96	12.10	175	1.70	4.27
Evaporated 10 % Temperature (°C)	r_D86auto	E10_NOT4 R_D86auto	180	1.73	4.37
35	1.33	3.20	185	1.77	4.46
40	1.33	3.20	190	1.81	4.56
45	1.33	3.20	195	1.85	4.65
50	1.33	3.20	200	1.89	4.75
55	1.33	3.20	205	1.92	4.84
60	1.33	3.20	210	1.96	4.94
65	1.33	3.20	215	2.00	5.03
70	1.33	3.20	220	2.04	5.13
75	1.33	3.20	225	2.07	5.22
80	1.33	3.20	230	2.11	5.32
85	1.33	3.20	235	2.15	5.41
90	1.33	3.20	240	2.19	5.51
95	1.33	3.20	245	2.23	5.60
Recovered 10 % Temperature (°C)	r_D86auto	T10_GRP4 R_D86auto	250	2.26	5.70
160	1.50	3.52	255	2.30	5.79
165	1.55	3.63	Recovered 90 % Temperature (°C)	r_D86auto	T90_GRP4 R_D86auto
170	1.60	3.74	180	0.74	2.70
175	1.65	3.85	185	0.76	2.78
180	1.69	3.96	190	0.78	2.85
185	1.74	4.07	195	0.80	2.93
190	1.79	4.18	200	0.82	3.00
195	1.83	4.29	205	0.84	3.08
200	1.88	4.40	210	0.86	3.15

215	0.88	3.23	Recovered 95 %	T95_GRP4 Diesel	
220	0.90	3.30	Temperature (°C)	r_D86auto	R_D86auto
225	0.92	3.38	260	1.82	5.08
230	0.94	3.45	265	1.89	5.29
235	0.96	3.53	270	1.97	5.50
240	0.98	3.60	275	2.05	5.71
245	1.00	3.68	280	2.12	5.92
250	1.03	3.75	285	2.20	6.13
255	1.05	3.83	290	2.27	6.35
260	1.07	3.90	295	2.35	6.56
265	1.09	3.98	300	2.42	6.77
270	1.11	4.05	305	2.50	6.98
275	1.13	4.13	310	2.58	7.19
280	1.15	4.20	315	2.65	7.40
285	1.17	4.28	320	2.73	7.61
290	1.19	4.35	325	2.80	7.83
295	1.21	4.43	330	2.88	8.04
300	1.23	4.50	335	2.95	8.25
305	1.25	4.58	340	3.03	8.46
310	1.27	4.65	Evaporated FBP		FBP_NOT4
315	1.29	4.73	Temperature (°C)	r_D86auto	R_D86auto
320	1.31	4.80	135–260	3.33	6.78
325	1.33	4.88	Recovered FBP		FBP_GRP4
330	1.35	4.95	Temperature (°C)	r_D86auto	R_D86auto
335	1.37	5.03	195–365	2.2	7.1
340	1.39	5.10			

A2. DETAILED DESCRIPTION OF APPARATUS

A2.1 *Distillation Flasks*—Flasks shall be of heat resistant glass, constructed to the dimensions and tolerances shown in Fig. A2.1 and shall otherwise comply with the requirements of Specification E1405. Flask A (100 mL) may also be constructed with a ground glass joint, in which case the diameter of the neck shall be the same as the 125-mL flask.

NOTE A2.1—For tests specifying dry point, specially selected flasks with bottoms and walls of uniform thickness are desirable.

A2.2 *Condenser and Condenser Bath*—Typical types of condenser and condenser baths are illustrated in Figs. 1 and 2.

A2.2.1 The condenser shall be made of seamless noncorrosive metal tubing, 560 ± 5 mm in length, with an outside diameter of 14 mm and a wall thickness of 0.8 to 0.9 mm.

NOTE A2.2—Brass or stainless steel has been found to be a suitable material for this purpose.

A2.2.2 The condenser shall be set so that 393 ± 3 mm of the tube is in contact with the cooling medium, with 50 ± 3 mm outside the cooling bath at the upper end, and with 114 ± 3 mm outside at the lower end. The portion of the tube projecting at the upper end shall be set at an angle of $75 \pm 3^\circ$ with the vertical. The portion of the tube inside the condenser bath shall be either straight or bent in any suitable continuous smooth curve. The average gradient shall be $15 \pm 1^\circ$ with respect to the horizontal, with no 10-cm section having a gradient outside of the $15 \pm 3^\circ$ range. The projecting lower portion of the condenser tube shall be curved downward for a length of 76 mm and the lower end shall be cut off at an acute angle. Provisions shall be made to enable the flow of the distillate to run down the side of the receiving cylinder. This can be accomplished by using a drip-deflector, which is attached to the outlet of the tube. Alternatively, the lower portion of the condenser tube can be curved slightly backward to ensure

contact with the wall of the receiving cylinder at a point 25 to 32 mm below the top of the receiving cylinder. Fig. A2.3 is a drawing of an acceptable configuration of the lower end of the condenser tube.

A2.2.3 The volume and the design of the bath will depend on the cooling medium employed. The cooling capacity of the bath shall be adequate to maintain the required temperature for the desired condenser performance. A single condenser bath may be used for several condenser tubes.

A2.3 *Metal Shield or Enclosure for Flask*. (Manual units only).

A2.3.1 *Shield for Gas Burner* (see Fig. 1)—The purpose of this shield is to provide protection for the operator and yet allow easy access to the burner and to the distillation flask during operation. A typical shield would be 480-mm high, 280-mm long and 200-mm wide, made of sheet metal of 0.8-mm thickness (22 gauge). The shield shall be provided with at least one window to observe the dry point at the end of the distillation.

A2.3.2 *Shield for Electric Heater* (see Fig. 2)—A typical shield would be 440-mm high, 200-mm long, and 200-mm wide, made of sheet metal of approximately 0.8-mm thickness (22 gauge) and with a window in the front side. The shield shall be provided with at least one window to observe the dry point at the end of the distillation.

A2.4 Heat Source

A2.4.1 *Gas Burner* (see Fig. 1), capable of bringing over the first drop from a cold start within the time specified and of continuing the distillation at the specified rate. A sensitive manual control valve and gas pressure regulator to give complete control of heating shall be provided.

A2.4.2 *Electric Heater* (see Fig. 2), of low heat retention.

NOTE A2.3—Heaters, adjustable from 0 to 1000 W, have been found to be suitable for this purpose.

A2.5 Flask Support

A2.5.1 *Type 1*—Use a Type 1 flask support with a gas burner (see Fig. 1). This support consists of either a ring support of the ordinary laboratory type, 100 mm or larger in diameter, supported on a stand inside the shield, or a platform adjustable from the outside of the shield. On this ring or platform is mounted a hard board made of ceramic or other heat-resistant material, 3 to 6 mm in thickness, with a central opening 76 to 100 mm in diameter, and outside line dimensions slightly smaller than the inside boundaries of the shield.

A2.5.2 *Type 2*—Use a Type 2 flask support assembly with electric heating (see Fig. 2 as one example). The assembly consists of an adjustable system onto which the electric heater is mounted with provision for placement of a flask support board (see A2.6) above the electric heater. The whole assembly is adjustable from the outside of the shield.

A2.6 *Flask Support Board*—The flask support board shall be constructed of ceramic or other heat-resistant material, 3 to 6 mm in thickness. Flask support boards are classified as A, B, or C, based on the size of the centrally located opening, the dimension of which is shown in Table 1. The flask support board shall be of sufficient dimension to ensure that thermal heat to the flask only comes from the central opening and that extraneous heat to the flask other than through the central opening is minimized. (**Warning**—Asbestos-containing materials shall not be used in the construction of the flask support board.)

A2.7 The flask support board can be moved slightly in different directions on the horizontal plane to position the distillation flask so that direct heat is applied to the flask only through the opening in this board. Usually, the position of the

flask is set by adjusting the length of the side-arm inserted into the condenser.

A2.8 Provision shall be made for moving the flask support assembly vertically so that the flask support board is in direct contact with the bottom of the distillation flask during the distillation. The assembly is moved down to allow for easy mounting and removal of the distillation flask from the unit.

A2.9 *Receiving Cylinders*—The receiving cylinder shall have a capacity to measure and collect 100 ± 1.0 mL. The shape of the base shall be such that the receiver does not topple when placed empty on a surface inclined at an angle of 13° from the horizontal.

A2.9.1 *Manual Method*—The cylinder shall be graduated at intervals of 1 mL beginning at least at 5 mL and have a graduation at the 100-mL mark. Construction details and tolerances for the graduated cylinder are shown in Fig. A2.4.

A2.9.2 *Automated Method*—The cylinder shall conform to the physical specifications described in Fig. A2.4, except that graduations below the 100-mL mark are permitted, as long as they do not interfere with the operation of the level follower. Receiving cylinders for use in automated units may also have a metal base.

A2.9.3 If required, the receiving cylinder shall be immersed during the distillation to above the 100-mL graduation line in a cooling liquid contained in a cooling bath, such as a tall-form beaker of clear glass or transparent plastic. Alternatively, the receiving cylinder may be placed in a thermostated bath air circulation chamber.

A2.10 *Residue Cylinder*—The graduated cylinder shall have a capacity of 5 or 10 mL, with graduations into 0.1 mL subdivisions, beginning at 0.1 mL. The top of the cylinder may be flared, the other properties shall conform to Specification E1272.

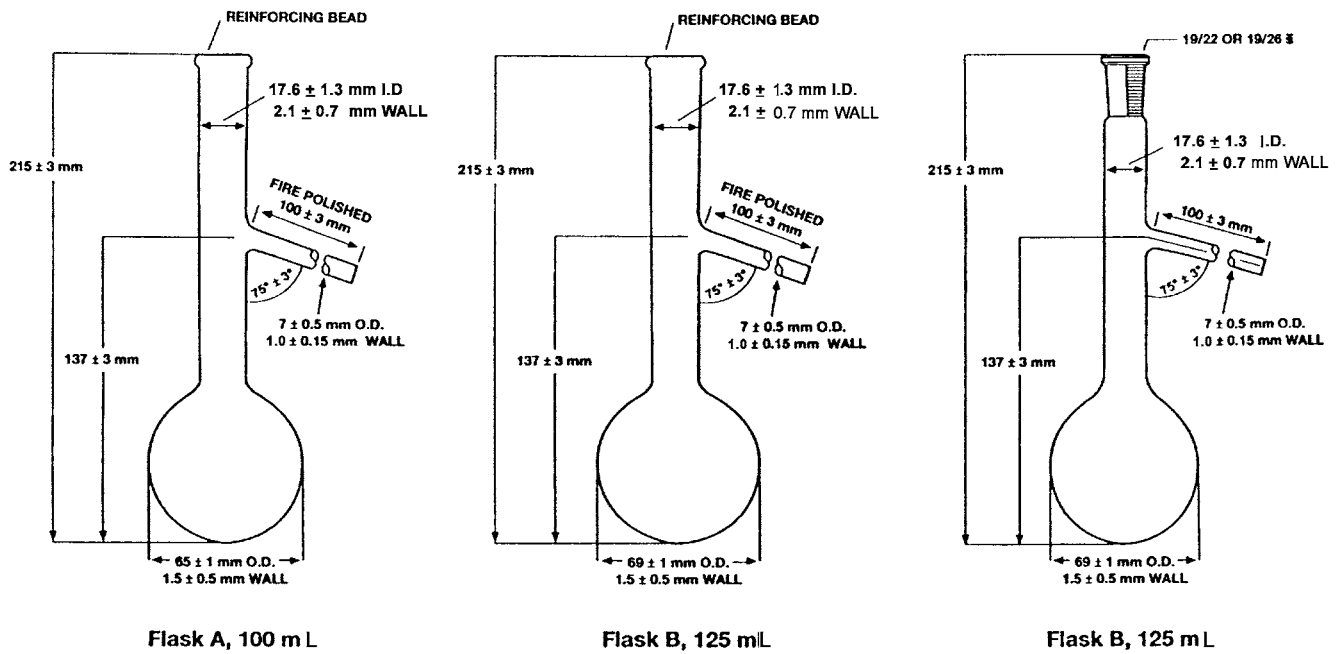

Flask A, 100 mL

Flask B, 125 mL

Flask B, 125 mL

FIG. A2.1 Flask A, 100 mL, Flask B, 125 mL, and Flask B with Ground Glass Joint, 125 mL

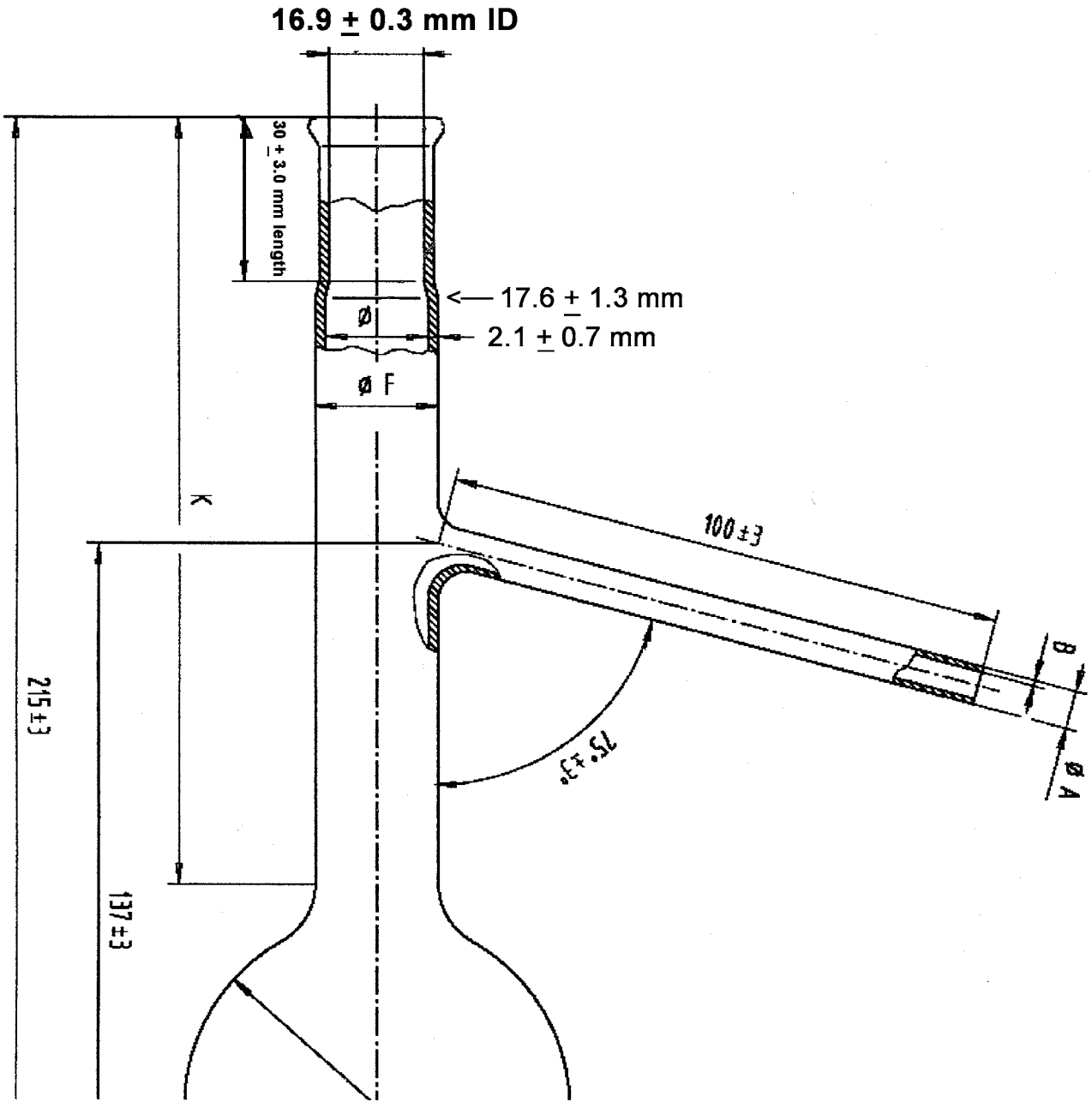
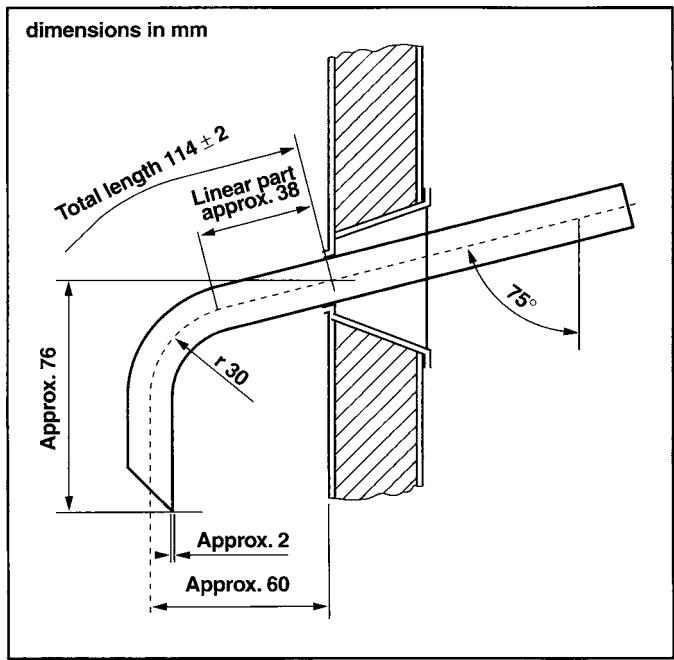
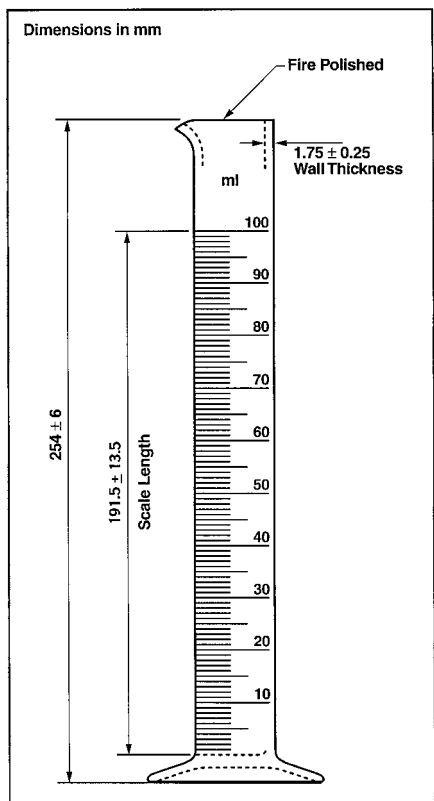

FIG. A2.2 Detail of Upper Neck Section



Lower End of Condenser Tube
 FIG. A2.3 Lower End of Condenser Tube



NOTE—1 mL graduations – minimum 5 to 100 mL
 FIG. A2.4 100 mL Graduated Cylinder

A3. DETERMINATION OF THE DIFFERENCE IN LAG TIME BETWEEN AN ELECTRONIC TEMPERATURE MEASUREMENT SYSTEM AND A MERCURY-IN-GLASS THERMOMETER

A3.1 The response time of an electronic temperature measuring device is inherently more rapid than that of a mercury-in-glass thermometer. The temperature measuring device assembly in general use, consisting of the sensor and its casing, or an electronic system and its associated software, or both, is so designed that the temperature measuring system will simulate the temperature lag of the mercury-in-glass thermometer.

A3.2 To determine the difference in lag time between such a temperature measuring system and a mercury-in-glass thermometer, analyze a sample such as gasoline, kerosine, jet fuel, or light diesel fuel with the electronic temperature measurement system in place and in accordance with the procedures described in this test method. In most cases this is the standard distillation step performed with an automated unit.

A3.2.1 Do not use a single pure compound, a very narrow boiling range product, or a synthetic blend of less than six compounds for this test.

A3.2.2 Best results are obtained with a sample that is typical of the sample load of the laboratory. Alternatively, use a full-range mixture with a 5 to 95 % boiling range of at least 100°C.

A3.3 Replace the electronic temperature measuring device with a low range or a high range mercury-in-glass thermometer, depending on the boiling range of the sample.

A3.4 Repeat the distillation with this thermometer, and manually record the temperature at the various percent recovered as described in 10.14.

A3.5 Calculate the values for the repeatability for the observed slope ($\Delta T/\Delta V$) for the different readings in the test.

A3.6 Compare the test data obtained using these two temperature measuring devices. The difference at any point shall be equal to, or less than, the repeatability of the method at that point. If this difference is larger, replace the electronic temperature measuring device or adjust the electronics involved, or both.

A4. PROCEDURE TO DETERMINE THE PERCENT EVAPORATED OR PERCENT RECOVERED AT A PRESCRIBED TEMPERATURE READING

A4.1 Many specifications require specific percentages evaporated or recovered at prescribed temperature readings, either as maxima, minima, or ranges. The procedures to determine these values are frequently designated by the terms Exxx or Rxxx, where xxx is the desired temperature.

NOTE A4.1—Regulatory standards on the certification of reformulated gasoline under the complex model procedure require the determination of E200 and E300, defined as the percent evaporated fuel at 93.3°C (200°F) and 148.9°C (300°F), respectively. E158, the percent evaporated at a distillation temperature of 70°C (158°F), is also used in describing fuel volatility characteristics. Other typical temperatures are R 200 for kerosines and R 250 and R 350 for gas oils, where R 200, R 250, and R 350 are the percent recovered fuel at 200°C, 250°C, and 350°C, respectively.

A4.2 Determine the barometric pressure, and calculate the correction to the desired temperature reading using Eq 3, Eq 4, or Eq 5 for $t = xxx^{\circ}\text{C}$ (or $t_f = xxx^{\circ}\text{F}$).

A4.2.1 *Manual Method*—Determine this correction to 0.5°C (1°F).

A4.2.2 *Automated Method*—Determine this correction to 0.1°C (0.2°F).

A4.3 Determine the expected temperature reading to yield $xxx^{\circ}\text{C}$ (or $xxx^{\circ}\text{F}$) after the barometric correction. To obtain the expected value, add the absolute value of the calculated correction to the desired temperature if the barometric pressure is above 101.3 kPa. If the barometric pressure is below 101.3 kPa, subtract the absolute value of the calculated correction from the desired temperature.

A4.4 Perform the distillation, as described in Section 10,

while taking into account A4.5 and A4.6.

A4.5 Manual Distillation

A4.5.1 In the region between about 10°C below and 10°C above the desired expected temperature reading determined in A4.3 record the temperature reading in intervals of 1 volume %.

A4.5.2 If the intent of the distillation is to solely determine the value of Exxx or Rxxx, discontinue the distillation after at least another 2 mL of distillate have been collected. Otherwise, continue the distillation, as described in Section 10, and determine the observed loss, as described in 11.1.

A4.5.2.1 If the intent of the distillation is to determine the value of Exxx and the distillation was terminated after about 2 mL of distillate was collected beyond the desired temperature, allow the distillate to drain into the receiving graduate. Allow the contents of the flask to cool to below approximately 40°C and then drain its contents into the receiving graduate. Note the volume of product in the receiving graduate to the nearest 0.5 mL at 2 min intervals until two successive observations agree.

A4.5.2.2 The amount recovered in the receiving graduate is the percent recovery. Determine the amount of observed loss by subtracting the percent recovery from 100.0.

A4.6 Automated Distillation

A4.6.1 In the region between about 10°C below and 10°C above the desired expected temperature reading determined in A4.3, collect temperature-volume data at 0.1 volume % intervals or less.

TABLE A4.1 Precision for Percent Evaporated at a Prescribed Temperature—Gasoline (Consolidated Equation)

Valid Range E70 – E180°C (Automated Apparatus)		
D86 Auto	r	R
	0.00836 (150 – X)	0.0200 (150 – X)

where: X = percent evaporated at the prescribed temperature

A4.6.2 Continue the distillation, as described in Section 10, and determine the percent loss, as described in 11.1.

A4.7 Calculations

A4.7.1 *Manual Method*—If a volume % recovered reading is not available at the exact temperature calculated in A4.3, determine the percent recovered by interpolation between the two adjacent readings. Either the linear, as described in 11.6.1, or the graphical procedure, as described in 11.6.2, is permitted. The percent recovered is equal to Rxxx.

A4.7.2 *Automated Method*—Report the observed volume to 0.1 volume % corresponding to the temperature closest to the expected temperature reading. This is the percent recovered, or Rxxx.

A4.7.3 *Manual and Automated Methods*—To determine the value of Exxx, add the observed loss to the percent recovered, Rxxx, as determined in A4.7.1 or A4.7.2 and as described in Eq 9.

A4.7.3.1 As prescribed in 12.6, do not use the corrected loss.

A4.8 *Precision*—The statistical determination of the precision of the volume % evaporated or recovered at a prescribed temperature for automated apparatus were derived according to Practice D6300 from a 2005 interlaboratory program.⁸ Table A4.1 shows the consolidated equations for volume % evaporated for gasoline, Table A4.2 shows the precision for volume % recovered for diesel. The precision is valid only for the range of temperatures stated. The estimation of precision for temperature points outside the stated range can be calculated from the procedures in A4.10 and the precision tables in Annex A1.

A4.9 The statistical determination of the precision of the volume % evaporated or recovered at a prescribed temperature for manual apparatus has not been directly measured in an interlaboratory program. It can be shown that the precision of the volume % evaporated or recovered at a prescribed temperature is equivalent to the precision of the temperature measurement at that point divided by the rate of change of temperature versus volume % evaporated or recovered. The estimation of precision becomes less precise at high slope values.

A4.10 Calculate the slope or rate of change in temperature reading, S_C (or S_F), as described in A4.10.1 and Eq A4.1 and using temperature values bracketing the desired temperature.

A4.10.1 *Slope or Rate of Change of Temperature:*

A4.10.1.1 To determine the precision of a result, it is generally necessary to determine the slope or rate of change of the temperature at that particular point. This variable, denoted as S_C or S_F , is equal to the change in temperature, either in °C or in °F, respectively, per percent recovered or evaporated.

A4.10.1.2 The precision of the IBP and EP does not require any slope calculation.

A4.10.1.3 With the exception stated in A4.10.1.2, the slope at any point during the distillation is calculated from the following equations, using the values shown in Table A4.3:

$$S_C \text{ (or } S_F) = (T_U - T_L) / (V_U - V_L) \quad (\text{A4.1})$$

where:

S_C = the slope, °C/volume %,

S_F = the slope, °F/volume %,

T_U = the upper temperature, °C (or °F),

T_L = the lower temperature, °C (or °F),

V_U = the volume % recovered or evaporated corresponding to T_U ,

V_L = the volume % recovered or evaporated corresponding to T_L , and

V_{EP} = the volume % recovered or evaporated corresponding to the end point.

A4.10.1.4 In the event that the distillation end point occurs prior to the 95 % point, the slope at the end point is calculated as follows:

$$S_C \text{ (or } S_F) = (T_{EP} - T_{HR}) / (V_{EP} - V_{HR}) \quad (\text{A4.2})$$

where:

T_{EP} or T_{HR} = the temperature, in °C or °F, at the percent volume recovered indicated by the subscript, and

V_{EP} or V_{HR} = the volume % recovered.

Subscript EP = end point, and

Subscript HR = highest reading, either 80 % or 90 %, prior to the end point.

A4.10.1.5 For points between 10 to 85 % recovered that are not shown in Table A4.3, the slope is calculated as follows:

$$S_C \text{ (or } S_F) = 0.05 (T_{(v+10)} - T_{(v-10)}) \quad (\text{A4.3})$$

A4.10.2 Calculate the repeatability, r , or the reproducibility, R , from the slope, S_C (or S_F) and the data in Tables A4.4 and A4.5.

A4.10.3 Determine the repeatability or reproducibility, or both, of the volume % evaporated or recovered at a prescribed temperature from the following formulas:

$$r_{\text{volume \%}} = r/S_C \text{ (or } S_F) \quad (\text{A4.4})$$

TABLE A4.2 Precision for Percent Recovered at a Prescribed Temperature—Diesel (Rxxx)

Valid Range R200 – R300°C (Automated Apparatus)	
D86 Auto	R200C, R250C, R300C
	r
	1.07
	R
	2.66

TABLE A4.3 Data Points for Determining Slope, S_C or S_F

Slope at %	IBP	5	10	20	30	40	50	60	70	80	90	95	EP
T_L at %	0	0	0	10	20	30	40	50	60	70	80	90	95
T_U at %	5	10	20	30	40	50	60	70	80	90	90	95	V_{EP}
$V_U - V_L$	5	10	20	20	20	20	20	20	20	20	10	5	$V_{EP} - 95$

TABLE A4.4 Repeatability and Reproducibility for Group 1

Evaporated Point, %	Manual Repeatability ^A		Manual Reproducibility ^A	
	°C	°F	°C	°F
IBP	3.3	6	5.6	10
5	1.9+0.86 S_C	3.4+0.86 S_F	3.1+1.74 S_C	5.6+1.74 S_F
10	1.2+0.86 S_C	2.2+0.86 S_F	2.0+1.74 S_C	3.6+1.74 S_F
20	1.2+0.86 S_C	2.2+0.86 S_F	2.0+1.74 S_C	3.6+1.74 S_F
30–70	1.2+0.86 S_C	2.2+0.86 S_F	2.0+1.74 S_C	3.6+1.74 S_F
80	1.2+0.86 S_C	2.2+0.86 S_F	2.0+1.74 S_C	3.6+1.74 S_F
90	1.2+0.86 S_C	2.2+0.86 S_F	0.8+1.74 S_C	1.4+1.74 S_F
95	1.2+0.86 S_C	2.2+0.86 S_F	1.1+1.74 S_C	1.9+1.74 S_F
FBP	3.9	7	7.2	13

^A S_C or S_F is the average slope (or rate of change) calculated in accordance with A4.10.1. Table A4.4 precision data obtained from RR study on both manual and automated D86 units by North American and IP laboratories.

TABLE A4.5 Repeatability and Reproducibility for Groups 2, 3 and 4 (Manual Method)

	Repeatability ^A		Reproducibility ^A	
	°C	°F	°C	°F
IBP	1.0+0.35 S_C	1.9+0.35 S_F	2.8+0.93 S_C	5.0+0.93 S_F
5–95 %	1.0+0.41 S_C	1.8+0.41 S_F	1.8+1.33 S_C	3.3+1.33 S_F
FBP	0.7+0.36 S_C	1.3+0.36 S_F	3.1+0.42 S_C	5.7+0.42 S_F
% volume at temperature reading	0.7+0.92/ S_C	0.7+1.66/ S_F	1.5+1.78/ S_C	1.53+3.20/ S_F

^A S_C or S_F is the average slope (or rate of change) calculated in accordance with A4.10.1. Table A4.5 has been derived from the monographs in Figs. 6 and 7 in D86–97.

$$R_{\text{volume \%}} = R/S_C (S_F) \quad (\text{A4.5})$$

where:

- $r_{\text{volume \%}}$ = repeatability of the volume % evaporated or recovered,
- $R_{\text{volume \%}}$ = reproducibility of the volume % evaporated or recovered,
- r = repeatability of the temperature at the prescribed temperature at the observed percent distilled,

- R = reproducibility of the temperature at the prescribed temperature at the observed percent distilled, and
- $S_C (S_F)$ = rate of change in temperature reading in °C (°F) per the volume % evaporated or recovered.

A4.10.4 Examples on how to calculate the repeatability and the reproducibility are shown in Appendix X2.

APPENDIXES

(Nonmandatory Information)

X1. EXAMPLES ILLUSTRATING CALCULATIONS FOR REPORTING OF DATA

X1.1 The observed distillation data used for the calculation of the examples below are shown in the first three columns of Fig. X1.1.

X1.1.1 Temperature readings corrected to 101.3 kPa (760 mm Hg) pressure (see 11.3) are as follows:

$$\text{correction } (^{\circ}\text{C}) = 0.0009 (101.3 - 98.6) (273 + t_c) \quad (\text{X1.1})$$

$$\text{correction } (^{\circ}\text{F}) = 0.00012 (760 - 740) (460 + t_f) \quad (\text{X1.2})$$

X1.1.2 Loss correction to 101.3 kPa (see 11.4) are as follows. The data for the examples are taken from Fig. X1.1.

$$\text{corrected loss} = (0.5 + (4.7 - 0.5)/ \quad (\text{X1.3})$$

$$\{1 + (101.3 - 98.6)/8.0\} = 3.6$$

X1.1.3 Recovery correction to 101.3 kPa (see 11.4.1) are as follows:

$$\text{corrected recovery} = 94.2 + (4.7 - 3.6) = 95.3 \quad (\text{X1.4})$$

X1.2 Temperature Readings at Prescribed Percent Evaporated

X1.2.1 Temperature reading at 10 % evaporated (4.7 % observed loss = 5.3 % recovered) (see 11.6.1) are as follows:

$$T_{10E} (^{\circ}\text{C}) = 33.7 + [(40.3 - 33.7) \quad (\text{X1.5})$$

$$(5.3 - 5)/(10 - 5)] = 34.1^{\circ}\text{C}$$

$$T_{10E} (^{\circ}\text{F}) = 92.7 + [(104.5 - 92.7) \quad (\text{X1.6})$$

$$(5.3 - 5)/(10 - 5)] = 93.1^{\circ}\text{F}$$

X1.2.2 Temperature reading at 50 % evaporated (45.3 % recovered) (see 11.6.1) are as follows:

$$T_{50E} (^{\circ}\text{C}) = 93.9 + [(108.9 - 93.9) \quad (\text{X1.7})$$

$$(45.3 - 40)/(50 - 40)] = 101.9^{\circ}\text{C}$$

$$T_{50E} (^{\circ}\text{F}) = 201 + [(228 - 201) \quad (\text{X1.8})$$

$$(45.3 - 40)/(50 - 40)] = 215.3^{\circ}\text{F}$$

X1.2.3 Temperature reading at 90 % evaporated (85.3 % recovered) (see 11.6.1) are as follows:

$$T_{90E} (^{\circ}\text{C}) = 181.6 + [(201.6 - 181.6) \quad (\text{X1.9})$$

$$(85.3 - 85)/(90 - 85)] = 182.8^{\circ}\text{C}$$

$$T_{90E} (^{\circ}\text{F}) = 358.9 + [(394.8 - 358.9) \quad (\text{X1.10})$$

$$(85.3 - 85)/(90 - 85)] = 361.0^{\circ}\text{F}$$

X1.2.4 Temperature reading at 90 % evaporated (85.3 % recovered) not corrected to 101.3 kPa pressure (see 11.6.1) are as follows:

$$T_{90E} (^{\circ}\text{C}) = 180.5 + [(200.4 - 180.5) \quad (\text{X1.11})$$

$$(85.3 - 85)/(90 - 85)] = 181.7^{\circ}\text{C}$$

$$T_{90E} (^{\circ}\text{F}) = 357 + [(392 - 357) \quad (\text{X1.12})$$

$$(85.3 - 85)/(90 - 85)] = 359.1^{\circ}\text{F}$$

NOTE X1.1—Results calculated from $^{\circ}\text{C}$ data may not correspond exactly to results calculated from $^{\circ}\text{F}$ data because of errors in rounding.

% recovered	Barometric pressure				% evaporated	procedure	
	observed		corrected			arithmetical	graphical
	98.6 kPa	740 mm Hg	101.3 kPa	760 mm Hg			
	$^{\circ}\text{C}$	$^{\circ}\text{F}$	$^{\circ}\text{C}$	$^{\circ}\text{F}$	$^{\circ}\text{C}$	$^{\circ}\text{F}$	
IBP	25.5	78	26.2	79.2	5	26.7	80.0
5	33.0	91	33.7	92.7	10	34.1	93.4
10	39.5	103	40.3	104.5	15	40.7	105.2
15	46.0	115	46.8	116.2	20	47.3	117.1
20	54.5	130	55.3	131.5	30	65.7	150.2
30	74.0	165	74.8	166.7	40	84.9	184.9
40	93.0	199	93.9	201.0	50	101.9	215.3
50	108.0	226	108.9	228.0	60	116.9	242.4
60	123.0	253	124.0	255.1	70	134.1	273.3
70	142.0	288	143.0	289.4	80	156.0	312.8
80	166.5	332	167.6	333.6	85	168.4	335.1
85	180.5	357	181.6	358.9	90	182.8	361.0
90	200.4	393	201.6	394.8	95	202.4	396.3
EP	215.0	419	216.2	421.1			
recovered, %	94.2		95.3				
residue, %	1.1		1.1				
loss, %	4.7		3.6				

FIG. X1.1 Example of Test Report

X2. EXAMPLES OF CALCULATION OF REPEATABILITY AND REPRODUCIBILITY OF VOLUME % (RECOVERED OR EVAPORATED) AT A PRESCRIBED TEMPERATURE READING

X2.1 Some specifications require the reporting of the volume % evaporated or recovered at a prescribed temperature. Table X2.1 shows the distillation data of a Group 1 sample as obtained by a manual unit.

X2.2 Example Calculation

X2.2.1 For a Group 1 sample exhibiting distillation characteristics as per Table X2.1, as determined by a manual unit, the reproducibility of the volume evaporated, R_v volume %, at 93.3 $^{\circ}\text{C}$ (200 $^{\circ}\text{F}$) is determined as follows:

X2.2.1.1 Determine first the slope at the desired temperature:

$$S_C \% = 0.1 (T_{(20)} - T_{(10)}) \quad (\text{X2.1})$$

$$= 0.1 (94 - 83)$$

$$= 1.1$$

$$S_F \% = 0.1 (T_{(20)} - T_{(10)})$$

$$= 0.1 (201 - 182)$$

$$= 1.9$$

X2.2.2 From **Table A4.4**, determine the value of R , the reproducibility at the observed percentage distilled. In this case, the observed percentage distilled is 18 % and

$$\begin{aligned}
 R &= 2.0 + 1.74 (S_C) && (X2.2) \\
 &= 2.0 + 1.74 \times 1.1 \\
 &= 3.9 \\
 R &= 3.6 + 1.74 (S_F) \\
 &= 3.6 + 1.74 \times 1.9 \\
 &= 6.9
 \end{aligned}$$

X2.2.3 From the calculated value of R , determine the value of volume, as described in **A4.10**.

$$\begin{aligned}
 R \text{ volume } \% &= R/(S_C) && (X2.3) \\
 &= 3.9/1.1 \\
 &= 3.5 \\
 R \text{ volume } \% &= R/(S_F) \\
 &= 6.9/1.9
 \end{aligned}$$

= 3.6

TABLE X2.1 Distillation Data from a Group 1 Sample Manual Distillation

Distillation Point Recovered, mL	Temperature° C	Temperature °F	Volume (mL) Recovered at 93.3°C (200°F)
			18.0
10	84	183	
20	94	202	
30	103	217	
40	112	233	

Distillation Point Evaporated, mL	Temperature° C	Temperature° F	Volume (mL) Evaporated at 93.3°C (200°F)
			18.4
10	83	182	
20	94	201	
30	103	217	
40	111	232	

X3. TABLES OF CORRECTED LOSS FROM MEASURED LOSS AND BAROMETRIC PRESSURE

X3.1 The table presented as **Fig. X3.1** can be used to determine the corrected loss from the measured loss and the barometric pressure in kPa.

X3.2 The table presented as **Fig. X3.2** can be used to determine the corrected loss from the measured loss and the barometric pressure in mm Hg.

Barometric Pressure, kPa

from through	76.1	80.9	84.5	87.3	89.6	91.5	93.1	94.1	95.5	96.4	97.2	97.9	98.4	98.9	99.5	100.0	100.4	100.8	101.2	101.5	102.0	102.4	102.8	103.2
through	80.8	84.4	87.2	89.5	91.4	93.0	94.0	95.4	96.3	97.1	97.8	98.3	98.8	99.4	99.9	100.3	100.7	101.1	101.4	101.9	102.3	102.7	103.1	103.5
Observed Loss																								
Corrected Loss																								
Units	0	0.37	0.35	0.33	0.31	0.29	0.27	0.25	0.23	0.20	0.18	0.16	0.14	0.13	0.11	0.09	0.06	0.04	0.02	-0.00	-0.02	-0.06	-0.09	-0.13
	1	0.63	0.65	0.67	0.69	0.71	0.73	0.75	0.78	0.80	0.82	0.84	0.86	0.87	0.89	0.92	0.94	0.96	0.98	1.00	1.03	1.06	1.09	1.13
	2	0.89	0.95	1.01	1.08	1.14	1.20	1.26	1.33	1.40	1.46	1.52	1.57	1.62	1.68	1.75	1.81	1.87	1.94	2.00	2.08	2.17	2.27	2.38
	3	1.15	1.25	1.36	1.46	1.57	1.67	1.77	1.88	1.99	2.09	2.19	2.28	2.37	2.47	2.58	2.69	2.79	2.90	3.00	3.13	3.29	3.45	3.63
	4	1.41	1.56	1.70	1.84	1.99	2.14	2.28	2.43	2.59	2.73	2.87	3.00	3.12	3.26	3.41	3.56	3.70	3.85	4.00	4.18	4.40	4.63	4.89
	5	1.68	1.86	2.04	2.23	2.42	2.61	2.79	2.98	3.19	3.37	3.55	3.71	3.87	4.05	4.25	4.44	4.62	4.81	5.00	5.23	5.51	5.81	6.14
	6	1.94	2.16	2.39	2.61	2.84	3.08	3.30	3.53	3.78	4.01	4.23	4.42	4.62	4.84	5.08	5.31	5.53	5.77	6.00	6.28	6.63	6.99	7.40
	7	2.20	2.46	2.73	3.00	3.27	3.55	3.80	4.08	4.38	4.65	4.90	5.14	5.37	5.63	5.91	6.18	6.44	6.73	7.00	7.33	7.74	8.17	8.65
	8	2.46	2.76	3.07	3.38	3.70	4.02	4.31	4.63	4.98	5.28	5.58	5.85	6.12	6.41	6.74	7.06	7.36	7.69	8.00	8.38	8.86	9.35	9.90
	9	2.72	3.07	3.41	3.76	4.12	4.49	4.82	5.18	5.57	5.92	6.26	6.56	6.87	7.20	7.57	7.93	8.27	8.65	9.00	9.43	9.97	10.53	11.16
	10	2.98	3.37	3.76	4.15	4.55	4.96	5.33	5.73	6.17	6.56	6.94	7.28	7.62	7.99	8.41	8.81	9.19	9.60	10.00	10.48	11.08	11.71	12.41
	11	3.24	3.67	4.10	4.53	4.97	5.43	5.84	6.28	6.77	7.20	7.61	7.99	8.37	8.78	9.24	9.68	10.10	10.56	11.00	11.53	12.20	12.89	13.67
	12	3.50	3.97	4.44	4.92	5.40	5.90	6.35	6.83	7.36	7.84	8.29	8.71	9.12	9.57	10.07	10.56	11.02	11.52	12.00	12.59	13.31	14.07	14.92
	13	3.76	4.27	4.78	5.30	5.83	6.36	6.86	7.39	7.96	8.47	8.97	9.42	9.86	10.36	10.90	11.43	11.93	12.48	13.00	13.64	14.43	15.25	16.17
	14	4.03	4.58	5.13	5.69	6.25	6.83	7.36	7.94	8.56	9.11	9.64	10.13	10.61	11.15	11.74	12.31	12.85	13.44	14.00	14.69	15.54	16.43	17.43
	15	4.29	4.88	5.47	6.07	6.68	7.30	7.87	8.49	9.15	9.75	10.32	10.85	11.36	11.93	12.57	13.18	13.76	14.40	15.00	15.74	16.66	17.61	18.68
	16	4.55	5.18	5.81	6.45	7.10	7.77	8.38	9.04	9.75	10.39	11.00	11.56	12.11	12.72	13.40	14.06	14.68	15.36	16.00	16.79	17.77	18.79	19.94
	17	4.81	5.48	6.16	6.84	7.53	8.24	8.89	9.59	10.35	11.03	11.68	12.27	12.86	13.51	14.23	14.93	15.59	16.31	17.00	17.84	18.88	19.97	21.19
	18	5.07	5.78	6.50	7.22	7.96	8.71	9.40	10.14	10.94	11.66	12.35	12.99	13.61	14.30	15.07	15.80	16.50	17.27	18.00	18.89	20.00	21.15	22.44
	19	5.33	6.08	6.84	7.61	8.38	9.18	9.91	10.69	11.54	12.30	13.03	13.70	14.36	15.09	15.90	16.68	17.42	18.23	19.00	19.94	21.11	22.33	23.70
	20	5.59	6.39	7.18	7.99	8.81	9.65	10.41	11.24	12.14	12.94	13.71	14.41	15.11	15.88	16.73	17.55	18.33	19.19	20.00	20.99	22.23	23.51	24.95
Tenths	0.0	0.00	0.00	0.00	0.00	0.00	0.00	0.00	0.00	0.00	0.00	0.00	0.00	0.00	0.00	0.00	0.00	0.00	0.00	0.00	0.00	0.00	0.00	0.00
	0.1	0.03	0.03	0.03	0.04	0.04	0.05	0.05	0.06	0.06	0.06	0.07	0.07	0.07	0.08	0.08	0.09	0.09	0.10	0.10	0.11	0.11	0.12	0.13
	0.2	0.05	0.06	0.07	0.08	0.09	0.09	0.10	0.11	0.12	0.13	0.14	0.14	0.15	0.16	0.17	0.17	0.18	0.19	0.20	0.21	0.22	0.24	0.25
	0.3	0.08	0.09	0.10	0.12	0.13	0.14	0.15	0.17	0.18	0.19	0.20	0.21	0.22	0.24	0.25	0.26	0.27	0.29	0.30	0.32	0.33	0.35	0.38
	0.4	0.10	0.12	0.14	0.15	0.17	0.19	0.20	0.22	0.24	0.26	0.27	0.29	0.30	0.32	0.33	0.35	0.37	0.38	0.40	0.42	0.45	0.47	0.50
	0.5	0.13	0.15	0.17	0.19	0.21	0.23	0.25	0.28	0.30	0.32	0.34	0.36	0.37	0.39	0.42	0.44	0.46	0.48	0.50	0.53	0.56	0.59	0.63
	0.6	0.16	0.18	0.21	0.23	0.26	0.28	0.31	0.33	0.36	0.38	0.41	0.43	0.45	0.47	0.50	0.52	0.55	0.58	0.60	0.63	0.67	0.71	0.75
	0.7	0.18	0.21	0.24	0.27	0.30	0.33	0.36	0.39	0.42	0.45	0.47	0.50	0.52	0.55	0.58	0.61	0.64	0.67	0.70	0.74	0.78	0.83	0.88
	0.8	0.21	0.24	0.27	0.31	0.34	0.38	0.41	0.44	0.48	0.51	0.54	0.57	0.60	0.63	0.67	0.70	0.73	0.77	0.80	0.84	0.89	0.94	1.00
	0.9	0.24	0.27	0.31	0.35	0.38	0.42	0.46	0.50	0.54	0.57	0.61	0.64	0.67	0.71	0.75	0.79	0.82	0.86	0.90	0.95	1.00	1.06	1.13

FIG. X3.1 Corrected Loss from Observed Loss and Barometric Pressure kPa

Barometric Pressure, mm Hg.

from through	571 606	607 633	634 654	655 671	672 685	686 697	698 705	706 715	716 722	723 728	729 733	734 737	738 741	742 745	746 749	750 752	753 755	756 758	759 761	762 764	765 767	768 770	771 773	774 776	
Observed Loss	/ -- Corrected Loss ----->																								
Units	0	0.37	0.35	0.33	0.31	0.29	0.27	0.25	0.23	0.20	0.18	0.16	0.14	0.13	0.11	0.09	0.07	0.05	0.02	-0.00	-0.03	-0.06	-0.09	-0.13	-0.17
1	0.63	0.65	0.67	0.69	0.71	0.73	0.75	0.77	0.80	0.82	0.84	0.86	0.87	0.89	0.91	0.93	0.95	0.98	1.00	1.03	1.06	1.09	1.13	1.17	
2	0.89	0.95	1.01	1.07	1.14	1.20	1.26	1.32	1.39	1.45	1.51	1.57	1.62	1.68	1.74	1.80	1.86	1.93	2.00	2.08	2.17	2.27	2.38	2.50	
3	1.15	1.25	1.36	1.46	1.56	1.67	1.77	1.87	1.99	2.09	2.19	2.28	2.36	2.46	2.57	2.67	2.77	2.88	3.00	3.13	3.28	3.44	3.63	3.83	
4	1.41	1.55	1.70	1.84	1.99	2.14	2.27	2.42	2.58	2.72	2.86	2.99	3.11	3.25	3.40	3.54	3.68	3.83	4.00	4.19	4.39	4.62	4.88	5.17	
5	1.67	1.86	2.04	2.22	2.41	2.61	2.78	2.97	3.18	3.36	3.54	3.70	3.86	4.03	4.23	4.41	4.59	4.79	5.00	5.24	5.50	5.80	6.13	6.50	
6	1.93	2.16	2.38	2.61	2.84	3.07	3.29	3.52	3.77	3.99	4.21	4.41	4.60	4.82	5.05	5.28	5.50	5.74	6.00	6.29	6.61	6.97	7.38	7.84	
7	2.19	2.46	2.72	2.99	3.26	3.54	3.79	4.07	4.36	4.63	4.88	5.12	5.35	5.60	5.88	6.15	6.41	6.69	7.00	7.34	7.72	8.15	8.63	9.17	
8	2.46	2.76	3.07	3.37	3.69	4.01	4.30	4.62	4.96	5.27	5.56	5.83	6.09	6.38	6.71	7.02	7.32	7.64	8.00	8.40	8.84	9.33	9.88	10.50	
9	2.72	3.06	3.41	3.76	4.11	4.48	4.81	5.17	5.55	5.90	6.23	6.54	6.84	7.17	7.54	7.89	8.23	8.60	9.00	9.45	9.95	10.50	11.13	11.84	
10	2.98	3.36	3.75	4.14	4.54	4.94	5.31	5.71	6.15	6.54	6.91	7.25	7.58	7.95	8.37	8.76	9.14	9.55	10.00	10.50	11.06	11.68	12.38	13.17	
11	3.24	3.66	4.09	4.52	4.96	5.41	5.82	6.26	6.74	7.17	7.58	7.96	8.33	8.74	9.19	9.63	10.05	10.50	11.00	11.56	12.17	12.86	13.63	14.51	
12	3.50	3.96	4.43	4.91	5.39	5.88	6.33	6.81	7.34	7.81	8.26	8.67	9.07	9.52	10.02	10.50	10.96	11.46	12.00	12.61	13.28	14.03	14.88	15.84	
13	3.76	4.27	4.78	5.29	5.81	6.35	6.83	7.36	7.93	8.44	8.93	9.38	9.82	10.31	10.85	11.37	11.87	12.41	13.00	13.66	14.39	15.21	16.13	17.17	
14	4.02	4.57	5.12	5.67	6.24	6.82	7.34	7.91	8.53	9.08	9.61	10.09	10.57	11.09	11.68	12.24	12.78	13.36	14.00	14.71	15.51	16.39	17.38	18.51	
15	4.28	4.87	5.46	6.06	6.66	7.28	7.85	8.46	9.12	9.71	10.28	10.80	11.31	11.88	12.51	13.11	13.68	14.31	15.00	15.77	16.62	17.57	18.63	19.84	
16	4.54	5.17	5.80	6.44	7.09	7.75	8.35	9.01	9.72	10.35	10.95	11.51	12.06	12.66	13.33	13.98	14.59	15.27	16.00	16.82	17.73	18.74	19.88	21.18	
17	4.80	5.47	6.14	6.82	7.51	8.22	8.86	9.56	10.31	10.98	11.63	12.22	12.80	13.45	14.16	14.85	15.50	16.22	17.00	17.87	18.84	19.92	21.13	22.51	
18	5.06	5.77	6.49	7.21	7.94	8.69	9.37	10.11	10.91	11.62	12.30	12.93	13.55	14.23	14.99	15.72	16.41	17.17	18.00	18.93	19.95	21.10	22.38	23.84	
19	5.32	6.07	6.83	7.59	8.36	9.15	9.88	10.65	11.50	12.25	12.98	13.64	14.29	15.02	15.82	16.59	17.32	18.12	19.01	19.98	21.06	22.27	23.64	25.18	
20	5.58	6.37	7.17	7.97	8.79	9.62	10.38	11.20	12.09	12.89	13.65	14.35	15.04	15.80	16.64	17.46	18.23	19.08	20.01	21.03	22.17	23.45	24.89	26.51	
Tenths	0.0	0.00	0.00	0.00	0.00	0.00	0.00	0.00	0.00	0.00	0.00	0.00	0.00	0.00	0.00	0.00	0.00	0.00	0.00	0.00	0.00	0.00	0.00	0.00	
0.1	0.03	0.03	0.03	0.04	0.04	0.05	0.05	0.05	0.06	0.06	0.07	0.07	0.07	0.08	0.08	0.09	0.09	0.10	0.10	0.11	0.11	0.12	0.13	0.13	
0.2	0.05	0.06	0.07	0.08	0.08	0.09	0.10	0.11	0.12	0.13	0.13	0.14	0.15	0.16	0.17	0.17	0.18	0.19	0.20	0.21	0.22	0.24	0.25	0.27	
0.3	0.08	0.09	0.10	0.11	0.13	0.14	0.15	0.16	0.18	0.19	0.20	0.21	0.22	0.24	0.25	0.26	0.27	0.29	0.30	0.32	0.33	0.35	0.38	0.40	
0.4	0.10	0.12	0.14	0.15	0.17	0.19	0.20	0.22	0.24	0.25	0.27	0.28	0.30	0.31	0.33	0.35	0.36	0.38	0.40	0.42	0.44	0.47	0.50	0.53	
0.5	0.13	0.15	0.17	0.19	0.21	0.23	0.25	0.27	0.30	0.32	0.34	0.36	0.37	0.39	0.41	0.43	0.45	0.48	0.50	0.53	0.56	0.59	0.63	0.67	
0.6	0.16	0.18	0.21	0.23	0.25	0.28	0.30	0.33	0.36	0.38	0.40	0.43	0.45	0.47	0.50	0.52	0.55	0.57	0.60	0.63	0.67	0.71	0.75	0.80	
0.7	0.18	0.21	0.24	0.27	0.30	0.33	0.35	0.38	0.42	0.44	0.47	0.50	0.52	0.55	0.58	0.61	0.64	0.67	0.70	0.74	0.78	0.82	0.88	0.93	
0.8	0.21	0.24	0.27	0.31	0.34	0.37	0.41	0.44	0.48	0.51	0.54	0.57	0.60	0.63	0.66	0.70	0.73	0.76	0.80	0.84	0.89	0.94	1.00	1.07	
0.9	0.23	0.27	0.31	0.34	0.38	0.42	0.46	0.49	0.54	0.57	0.61	0.64	0.67	0.71	0.75	0.78	0.82	0.86	0.90	0.95	1.00	1.06	1.13	1.20	

FIG. X3.2 Corrected Loss from Observed Loss and Barometric Pressure mm Hg

X4. PROCEDURE TO EMULATE THE EMERGENT STEM ERROR OF A MERCURY-IN-GLASS THERMOMETER

X4.1 When an electronic or other sensor without an emergent stem error is used, the output of this sensor or the associated data system should emulate the output of a mercury-in-glass thermometer. Based on information supplied by four manufacturers of automated Test Method D86 equipment, the averaged equations shown in X4.2 and X4.3 have been reported to be in use.

X4.1.1 The equations shown in X4.2 have limited applicability and are shown for information purposes only. In addition to the correction for the emergent stem, the electronic sensor and associated data system will also have to emulate the lag in response time observed for mercury-in-glass thermometers.

X4.2 When a low range thermometer would have been used, no stem correction is to be applied below 20°C. Above this temperature, the correction is calculated using the following formula:

$$ASTM\ 7C\ T_{elr} = T_t - 0.000162 \times (T_t - 20^\circ C)^2 \quad (X4.1)$$

X4.3 When a high range thermometer would have been used, no stem correction is to be applied below 35°C. Above this temperature the correction is calculated using the following formula:

$$ASTM\ 8C\ T_{chr} = T_t - 0.000131 \times (T_t - 35^\circ C)^2 \quad (X4.2)$$

where:

T_{elr} = emulated temperature in °C for low range thermometers,

T_{chr} = emulated temperature in °C for high range thermometers, and

T_t = true temperature in °C.

X5. EXPLANATORY REPORT FORMS

X5.1 Fig. X5.1 and Fig. X5.2 show report forms.

"Percent Recovered" Report Form

Date:
 Time:
 Operator:

Ambient temperature (°C)
 Atmospheric pressure (kPa)
 Condenser temperature (°C)
 Temperature of the bath around receiving cylinder (°C)

	Percent Recovered	Corrected Temperature Reading (°C)	Time or mL / min
	IBP		
	5		
	10		
	15		
	20		
	25		
	30		
	35		
	40		
	45		
	50		
	55		
	60		
	65		
	70		
	75		
	80		
	85		
	90		
5 ml residue	95		
FBP			

Percent Recovery
 Percent Residue
 Percent Total Recovery
 Percent Loss Corrected Loss
 Corrected Percent Recovery Corrected Total Recovery

Ambient temperature at the start of the test

Ambient barometric pressure at the start of the test

Volume of condensate observed in the receiving cylinder at any point in the distillation, expressed as a percentage of the charge volume, in connection with simultaneous temperature reading

Temperature measuring device readings which are corrected to 101,3 kPa barometric pressure

Group 1, 2 & 3: 5 to 10 minutes
 Group 4: 5 to 15 minutes

Group 1 & 2: 60 to 100 seconds

4 to 5 ml / min uniform average rate from 5% recovered to 5 ml in flask

Volume of condensate observed in the receiving cylinder when the 5ml conditions are reached

Volume of condensate observed in the receiving cylinder when the final boiling point is observed

Maximum percent recovered

Volume of residue in the flask expressed as a percentage of the charge volume

Combined Percent Recovery and Percent Residue in the flask

Time from 5 ml in flask to FBP = < 5 minutes

100 minus the Total Recovery

Percent Recovery corrected for barometric pressure

Percent Loss corrected for barometric pressure

Combined Percent Recovery and Percent Residue in the flask corrected for barometric pressure

Comments:

FIG. X5.1 Percent Recovered Report Form

"Percent Evaporated" Report Form

Laboratory: _____

Date: _____
 Time: _____
 Operator: _____

Ambient temperature (°C) _____
 Atmospheric pressure (kPa) _____
 Condenser temperature (°C) _____
 Temperature of the bath around receiving cylinder (°C) _____

Percent Recovered	Corrected Temperature Reading (°C)	Time or mL / min	Percent Evaporated	Temperature Readings at prescribed percent evaporated (°C)
IBP			IBP	
5			5	
10			10	
15			15	
20			20	
25			25	
30			30	
35			35	
40			40	
45			45	
50			50	
55			55	
60			60	
65			65	
70			70	
75			75	
80			80	
85			85	
90			90	
5 ml residue				
95			95	
FBP			FBP	

Percent Recovery _____
 Percent Residue _____
 Percent Total Recovery _____
 Percent Loss _____
 Corrected Percent Recovery _____
 Corrected Loss _____
 Corrected Total Recovery _____

Comments: _____

Ambient temperature at the start of the test

Ambient barometric pressure at the start of the test

Volume of condensate observed in the receiving cylinder at any point in the distillation, expressed as a percentage of the charge volume, in connection with simultaneous temperature reading

Temperature measuring device readings which are corrected to 101,3 kPa barometric pressure

Sum of the percent recovered and the percent loss

Temperature measuring device readings at specified percentages evaporated calculated with arithmetical or graphical procedures

Group 0: 2 to 5 minutes
 Group 1, 2 & 3: 5 to 10 minutes
 Group 4: 5 to 15 minutes

Group 1 & 2: 60 to 100 seconds

Group 0: time from first application of heat to 10% recovered = 3 to 4 minutes
 Group 0, 1, 2, 3 & 4: 4 to 5 ml / min uniform average rate from 5% recovered to 5 ml in flask

Volume of condensate observed in the receiving cylinder when the 5ml conditions are reached

Volume of condensate observed in the receiving cylinder when the final boiling point is observed

Maximum percent recovered

Volume of residue in the flask expressed as a percentage of the charge volume

Combined Percent Recovery and Percent Residue in the flask

Time from 5 ml in flask to FBP = < 5 minutes

100 minus the Total Recovery

Percent Recovery corrected for barometric pressure

Percent Loss corrected for barometric pressure

Combined Percent Recovery and Percent Residue in the flask corrected for barometric pressure

FIG. X5.2 Percent Evaporated Report Form

SUMMARY OF CHANGES

Subcommittee D02.08 has identified the location of selected changes to this standard since the last issue (D86–10) that may impact the use of this standard. (Approved Aug. 1, 2010.)

- (1) Revised **9.2.1**.
- (2) Revised **Fig. 6**.
- (3) Revised **3.1.11**.
- (4) Revised **Fig. A2.4**.

Subcommittee D02.08 has identified the location of selected changes to this standard since the last issue (D86–09^{e1}) that may impact the use of this standard. (Approved May 15, 2010.)

- (1) Modified **1.1**.
- (2) Added new **Note 1** and research report.
- (3) Added Specification **D5798** and Terminology **D4175** to the Referenced Documents and standard text.
- (4) Added new **3.1.14**.

Subcommittee D02.08 has identified the location of selected changes to this standard since the last issue (D86–08a) that may impact the use of this standard. (Approved April 15, 2009.)

- (1) Revised **7.4.1.1**.
- (2) Revised **Table 1**.

Subcommittee D02.08 has identified the location of selected changes to this standard since the last issue (D86–08) that may impact the use of this standard. (Approved Dec. 15, 2008.)

- (1) Added **Note 28** and **Note 29**.
- (2) Added **A4.8** and renumbered remaining sections.
- (3) Updated **A4.9**.
- (4) Deleted automated information from **Tables A4.4 and A4.5**.
- (5) Added **Table A4.1** **Table A4.2** on automated precision.
- (6) Updated **Appendix X2**.

Subcommittee D02.08 has identified the location of selected changes to this standard since the last issue (D86–07b) that may impact the use of this standard. (Approved Nov. 15, 2008.)

- (1) Revised title of **Table 1**.
- (2) Revised **10.2**.

ASTM International takes no position respecting the validity of any patent rights asserted in connection with any item mentioned in this standard. Users of this standard are expressly advised that determination of the validity of any such patent rights, and the risk of infringement of such rights, are entirely their own responsibility.

This standard is subject to revision at any time by the responsible technical committee and must be reviewed every five years and if not revised, either reapproved or withdrawn. Your comments are invited either for revision of this standard or for additional standards and should be addressed to ASTM International Headquarters. Your comments will receive careful consideration at a meeting of the responsible technical committee, which you may attend. If you feel that your comments have not received a fair hearing you should make your views known to the ASTM Committee on Standards, at the address shown below.

This standard is copyrighted by ASTM International, 100 Barr Harbor Drive, PO Box C700, West Conshohocken, PA 19428-2959, United States. Individual reprints (single or multiple copies) of this standard may be obtained by contacting ASTM at the above address or at 610-832-9585 (phone), 610-832-9555 (fax), or service@astm.org (e-mail); or through the ASTM website (www.astm.org). Permission rights to photocopy the standard may also be secured from the ASTM website (www.astm.org/COPYRIGHT/).