



Standard Test Method for Saybolt Color of Petroleum Products (Saybolt Chromometer Method)¹

This standard is issued under the fixed designation D156; the number immediately following the designation indicates the year of original adoption or, in the case of revision, the year of last revision. A number in parentheses indicates the year of last reapproval. A superscript epsilon (ϵ) indicates an editorial change since the last revision or reapproval.

This standard has been approved for use by agencies of the Department of Defense.

1. Scope*

1.1 This test method covers the determination of the color of refined oils such as undyed motor and aviation gasoline, jet propulsion fuels, naphthas and kerosine, and, in addition, petroleum waxes and pharmaceutical white oils.

NOTE 1—For determining the color of petroleum products darker than Saybolt Color – 16, see Test Method [D1500](#).

1.2 This test method reports results specific to this test method and recorded as, “Saybolt Color units.”

1.3 The values stated in inch-pound units or in SI units and which are not in parentheses are to be regarded as the standard. The values given in parentheses are for information only.

NOTE 2—Oil tubes and apparatus used in this test method have traditionally been marked in inches, (the tube is required to be etched with $\frac{1}{8}$ in. divisions.) The Saybolt Color Numbers are aligned with inch, $\frac{1}{2}$ in., $\frac{1}{4}$ in., and $\frac{1}{8}$ in. changes in the depth of oil. These fractional inch changes do not readily correspond to SI equivalents and in view of the preponderance of apparatus already in use and marked in inches, the inch/pound unit is regarded as the standard. However the test method does use SI units of length when the length is not directly related to divisions on the oil tube and Saybolt Color Numbers. The test method uses SI units for temperature.

1.4 *This standard does not purport to address all of the safety concerns, if any, associated with its use. It is the responsibility of the user of this standard to establish appropriate safety and health practices and determine the applicability of regulatory limitations prior to use.*

2. Referenced Documents

2.1 ASTM Standards:²

[D938 Test Method for Congealing Point of Petroleum](#)

¹ This test method is under the jurisdiction of ASTM Committee [D02](#) on Petroleum Products and Lubricants and is the direct responsibility of Subcommittee [D02.05](#) on Properties of Fuels, Petroleum Coke and Carbon Material.

Current edition approved Dec. 1, 2007. Published January 2008. Originally approved in 1923. Last previous edition approved in 2007 as D156–07. DOI: 10.1520/D0156-07A.

² For referenced ASTM standards, visit the ASTM website, www.astm.org, or contact ASTM Customer Service at service@astm.org. For *Annual Book of ASTM Standards* volume information, refer to the standard’s Document Summary page on the ASTM website.

[Waxes, Including Petrolatum](#)

[D1500 Test Method for ASTM Color of Petroleum Products \(ASTM Color Scale\)](#)

[D4057 Practice for Manual Sampling of Petroleum and Petroleum Products](#)

3. Terminology

3.1 Definitions:

3.1.1 *clear-and-bright, n*—condition in which the sample is free of haze or cloudiness. (Also termed *clean-and-bright*.)

3.1.2 *free water, n*—water in excess of that soluble in the sample and appearing in the sample as a haze or cloudiness, as droplets, or as a separated phase or layer.

3.1.3 *particulates, n*—small solid or semisolid particles, sometimes referred to as silt or sediment, that can be suspended in the sample or can settle to the bottom.

3.1.4 *turbidity, n*—reduction of transparency of a sample due to the presence of particulate matter or water haze, or both.

3.2 Definitions of Terms Specific to This Standard:

3.2.1 *Saybolt color, n*—an empirical definition of the color of a clear petroleum liquid based on a scale of –16 (darkest) to +30 (lightest).

3.2.1.1 *Discussion*—The number is derived by finding the height of a column of the sample that, when viewed through the length of the column, visually matches the appropriate one of three glass standards and referring to [Table 1](#) of Test Method [D156](#).

4. Summary of Test Method

4.1 The height of a column of sample is decreased by levels corresponding to color numbers until the color of the sample is unmistakably lighter than that of the standard. The color number above this level is reported, regardless of whether the sample was darker, questionable, or a match at the higher level.

5. Significance and Use

5.1 Determination of the color of petroleum products is used mainly for manufacturing control purposes and is an important quality characteristic since color is readily observed by the user of the product. In some cases the color may serve as an indication of the degree of refinement of the material. When the color range of a particular product is known, a variation outside

*A Summary of Changes section appears at the end of this standard.

TABLE 1 Saybolt Colors Corresponding to Depths of Oil

Number of Color Standards	Depth of Oil, in. (mm)	Color Number	Number of Color Standards	Depth of Oil, in. (mm)	Color Number
One-half	20.00 (508)	+30	Two	6.00 (152)	+6
One-half	18.00 (457)	+29	Two	5.75 (146)	+5
One-half	16.00 (406)	+28	Two	5.50 (139)	+4
One-half	14.00 (355)	+27	Two	5.25 (133)	+3
One-half	12.00 (304)	+26	Two	5.00 (127)	+2
One	20.00 (508)	+25	Two	4.75 (120)	+1
One	18.00 (457)	+24	Two	4.50 (114)	0
One	16.00 (406)	+23	Two	4.25 (107)	-1
One	14.00 (355)	+22	Two	4.00 (101)	-2
One	12.00 (304)	+21	Two	3.75 (95)	-3
One	10.75 (273)	+20	Two	3.625 (92)	-4
One	9.50 (241)	+19	Two	3.50 (88)	-5
One	8.25 (209)	+18	Two	3.375 (85)	-6
One	7.25 (184)	+17	Two	3.25 (82)	-7
One	6.25 (158)	+16	Two	3.125 (79)	-8
Two	10.50 (266)	+15	Two	3.00 (76)	-9
Two	9.75 (247)	+14	Two	2.875 (73)	-10
Two	9.00 (228)	+13	Two	2.75 (69)	-11
Two	8.25 (209)	+12	Two	2.625 (66)	-12
Two	7.75 (196)	+11	Two	2.50 (63)	-13
Two	7.25 (184)	+10	Two	2.375 (60)	-14
Two	6.75 (171)	+9	Two	2.25 (57)	-15
Two	6.50 (165)	+8	Two	2.125 (53)	-16
Two	6.25 (158)	+7			

the established range can indicate possible contamination with another product. However, color is not always a reliable guide to product quality and should not be used indiscriminately in product specifications.

6. Apparatus

6.1 The Saybolt chromometer consisting of sample and standard tubes, optical system, light source, and color standards, is described in detail in [Annex A1](#) and illustrated in [Fig. A1.1](#).

7. Standardization of Apparatus

7.1 Remove the glass disk from the bottom of the oil tube. Clean the disk, oil tube, and plain tube. When deposits are not removable by wiping or solvent rinsing, wash with soap and water. After cleaning, rinse with distilled or deionized water and with acetone or some other suitable solvent, and dry. Assemble the oil tube, and position the tubes in the instrument.

7.2 Using the specified light source and illumination, observe the comparative light intensity of the two halves of the optical field, with both tubes empty, and with the 12-mm diaphragm removed from under the plain tube. The intensity of light observed in each half of the optical field must be the same. Adjustment in the position of the light source may be necessary to achieve this match.

NOTE 3—On some instruments, removal of the 12-mm diaphragm can prevent the assembly from seating against the base (about a 1/4 in. gap), which can let a lot of stray light in that may affect the light intensity when trying to compare the two halves of the optical field in 7.2. If this occurs, follow the procedure in 7.3 (where the 12-mm diaphragm has been reattached) as the basis to ensure the light source has been properly set to provide the same light intensity in both halves of the optical field.

7.3 Replace the 12-mm diaphragm under the plain tube, and fill the oil tube to the 20 in. (508-mm) mark with distilled or deionized water. The intensity of the light observed in each half of the optical field must be the same, for the instrument to be

judged satisfactory for use. The optical properties of glass, from different batches, can vary significantly and it is recommended that only matched tubes, such as described in the Appendix, be used in this test. When a tube is broken, replace both tubes with a matched pair of tubes.

8. Sampling

8.1 Samples shall be taken in accordance with the instructions in Practice [D4057](#).

9. Preparation of Test Specimen

9.1 *Samples (Excluding Waxes)*—If the sample is contained in a clear, transparent container, such as glass bottle, visually inspect the sample for evidence of free water, particulate contamination, and haze by holding the container up to the light. If the sample is contained in a nontransparent container, shake or agitate the sample container vigorously to uniformly suspend any free water that may be present in the sample before transferring a portion to a clear, transparent container to conduct the visual inspection before proceeding.

9.2 *Wax Samples*—Carry out the same procedure in 9.1, except that the sample is to be heated to a temperature corresponding to the range specified in 11.1 to ensure the sample is liquid. (**Warning**—Take appropriate safety precautions in handling the sample at elevated temperatures.)

9.3 When the sample is not clear-and-bright (that is, visual inspection in 9.1 or 9.2 shows any presence of turbidity, free water, or particulates, or a combination thereof), filter through a sufficient number of qualitative filter papers until it is clear. For wax samples requiring filtration, it will be necessary to heat the filter paper and apparatus (for example, a filter funnel) that can come in contact with the molten sample to a temperature in the range specified in 11.1 to prevent the sample from solidifying during the filtration process.

TABLE 2 Example of Procedure

Observation	Using One Whole Color Standard, in. (mm)	Using Two Whole Color Standards, in. (mm)
Oil darker at depth of	16 (406)	4.5 (102)
Oil darker at depth of	14 (355)	4.25 (107)
Oil questionable at depth of	12 (304)	4.0 (101)
Oil lighter at depth of	10.75 (273)	3.75 (95)
Saybolt color	+21	-2

9.4 When preparing petroleum wax for testing do not heat excessively, because oxidation can occur, with consequent discoloration of the test specimen.

10. Procedure for Refined Light Oils and Pharmaceutical White Oils

10.1 Flush the oil tube with a portion of the test specimen, taking care to allow the tube to drain thoroughly. Fill the oil tube with the test specimen compare with a whole color standard. When the test specimen is lighter than the color standard, remove the standard and replace it with a half standard. When the sample is darker than the single whole standard at 6¼ in. (158 mm), add another whole standard. (**Warning**—It is important that all samples in the color tubes be free from air bubbles.)

10.2 With the proper color standard or standards in place, and the test specimen in the oil tube at a level where its color is decidedly darker than that of the color standard, draw off the test specimen slowly by means of the petcock until the oil appears just slightly darker than the color standard. From this point, draw the test specimen level down to the nearest depth corresponding to color number as shown in **Table 1**. When the color of the oil observed through the eyepiece is still darker than the color standard, draw the oil down to the next depth given in **Table 1**, and compare. Continue this operation until a depth is reached where the test specimen and color standard match, or show questionable differences. At this point, lower the oil column to the next specified depth and, when the oil is unmistakably lighter than the color standard, record the color corresponding to the next higher level as the Saybolt color.

10.3 Experience in the use of this instrument will obviate the necessity of following the step-by-step procedure outlined in **10.2** for choosing the proper color standards for each sample. Examples of the procedure are given in **Table 2**.

11. Procedure for Petroleum Wax

11.1 Heat the wax test specimen to 8 to 17°C above its congealing point as determined in accordance with Test Method **D938**. Preheat the oil tube.

11.2 Pour the liquid wax into the oil tube; turn the heating element off, and, after the heat waves in the test specimen can no longer be noted, obtain the required readings as directed in **Section 10**.

12. Report

12.1 Report the recorded color units as “Saybolt color _____.” When the sample has been filtered, add the words “(sample filtered).”

13. Precision and Bias

13.1 The precision of this test is not known to have been obtained in accordance with currently accepted guidelines (Research Report D02-1007).

13.2 The precision of this test method as obtained by statistical examination of interlaboratory test results is as follows:

13.2.1 *Repeatability*—The difference between successive test results obtained by the same operator with the same apparatus under constant operating conditions on identical test material would, in the long run, in the normal and correct operation of the test method, exceed the following value only in one case in twenty:

1 color unit

13.2.2 *Reproducibility*—The difference between two single and independent test results obtained by different operators working in different laboratories on identical test material would, in the long run, in the normal and correct operation of the test method exceed the following value only in one case in twenty:

2 color units

13.3 *Bias*—The procedure in this test method has no bias because the value of Saybolt Color is subjective and can only be defined in terms of this test method.

14. Keywords

14.1 aviation gasoline; color; jet fuel; kerosine; motor gasoline; oils; petroleum wax; Saybolt Color; white oils

(Mandatory Information)

A1. APPARATUS



FIG. A1.1 ASTM Saybolt Chromometer and Artificial Daylight Lamp

A1.1 Saybolt Chromometer

A1.1.1 *Oil Sample Tube*—For testing liquids, use a borosilicate glass tube, or its equivalent in color characteristics, having an inside diameter of not less than 16.5 mm nor more than 17.5 mm, and an outside diameter of not less than 21.25 mm nor more than 22.75 mm. Close the tube at the bottom with an optical clear plano glass disk 6.25 mm thick, free of striations and scratches. The tube shall be 508 to 510 mm long from the upper surface of the plano disk to the top of the tube. Mount the tube and disk in a suitable metal collar provided with a petcock to permit controlled drainage of the tube (Fig. A1.1). Construct the collar in a manner that permits removal of the glass disk for cleaning. Graduate the tube with etched 1/8-in. (3.2-mm) divisions. Etch each inch-line completely around the tube, and number them consecutively from the 2-in. (50-mm) line up.

A1.1.1.1 The condition and the color of the glass tubes shall be such that no color difference is observed between the plain tube and the oil tube when the tubes are empty, or when the oil tube is filled with distilled or deionized water. Comparisons shall be made with the tubes positioned in the instrument in the manner described in Section 7.

A1.1.2 *Wax Sample Tube*—For testing petroleum waxes, use an oil tube that meets the specifications prescribed in A1.1.1 and that has a 60-W heater evenly distributed over its entire length, as shown in Fig. A1.2. Alternative means can be used for keeping the wax in a liquid state and providing a means for readability of the graduated scale.

A1.1.3 *Plain Tube*—Use a glass tube or its equivalent in color characteristics, 483 mm long, meeting the diameter specifications given in A1.1.1, and open at both ends, with one end mounted in a suitable metal collar. The overall length of the tube and collar, assembled, shall be 516 to 518 mm. The collar provides a place to locate the color standards and a black metal diaphragm with a circular aperture 12 mm in diameter in the optical field. See A1.1.1.1.

A1.1.4 *Tube Assembly*—Mount the tubes securely in a vertical and central position with respect to the optical viewer. Cover the upper ends of the tubes with removable diaphragmed metal caps about 25 mm in length. The caps shall be of sufficient diameter to slip easily over the ends of the tubes. The aperture in the diaphragm of the cap shall be 14 mm in diameter.

A1.1.5 *Optical Viewer*—Provide the chromometer with a suitable optical viewer head consisting of prisms and an eyepiece containing a lens. Provide prisms of a suitable form, matched in their refracting angles and areas, and so mounted as to avoid the possibility of disarrangement. Arrange the prisms so that the light rays passing through the tubes are deflected into an optical head and can be viewed by the eyepiece. The arrangement must be such as to provide a circular field of vision free from distortion and parallax (Note A1.1), one half of which is illuminated by the light transmitted by the sample, and the other half by the color standard.

NOTE A1.1—An adapter (Fig. A1.3) may be used to locate the light rays passing up through the center of the eyepiece. The adapter consists of a metal collar of such diameter as to fit the outside diameter of the eyepiece closely. It is approximately 50 mm long, and closed at one end with a metal diaphragm having a centrally located aperture approximately 2.5 mm in diameter.

A1.1.6 *Illumination*—Arrange for the light to be transmitted through the tubes by means of a reflecting mirror of either white opal glass or clear glass, with a uniform coating of untarnished silver on one surface. Fix the mirror at a suitable angle, and so arrange it that reflected light of equal intensity of radiation will pass through the tubes in parallel rays. Alternatively, diffused light can be projected directly up through the tubes from the base of the instrument.

A1.1.7 *Light Source*—For the light source, use an artificial daylight lamp so arranged as to project a diffused light up through the tubes. The diffused light shall be free of glare or shadows. Interfering light from all other sources shall be excluded.

A1.2 Color Standards

A1.2.1 The whole color standard and the half color standard shall be of such colorimetric characteristics that the trilinear coordinates x , y , and z , and the luminous transmission T_w , when calculated from the spectral transmission data using the 1931

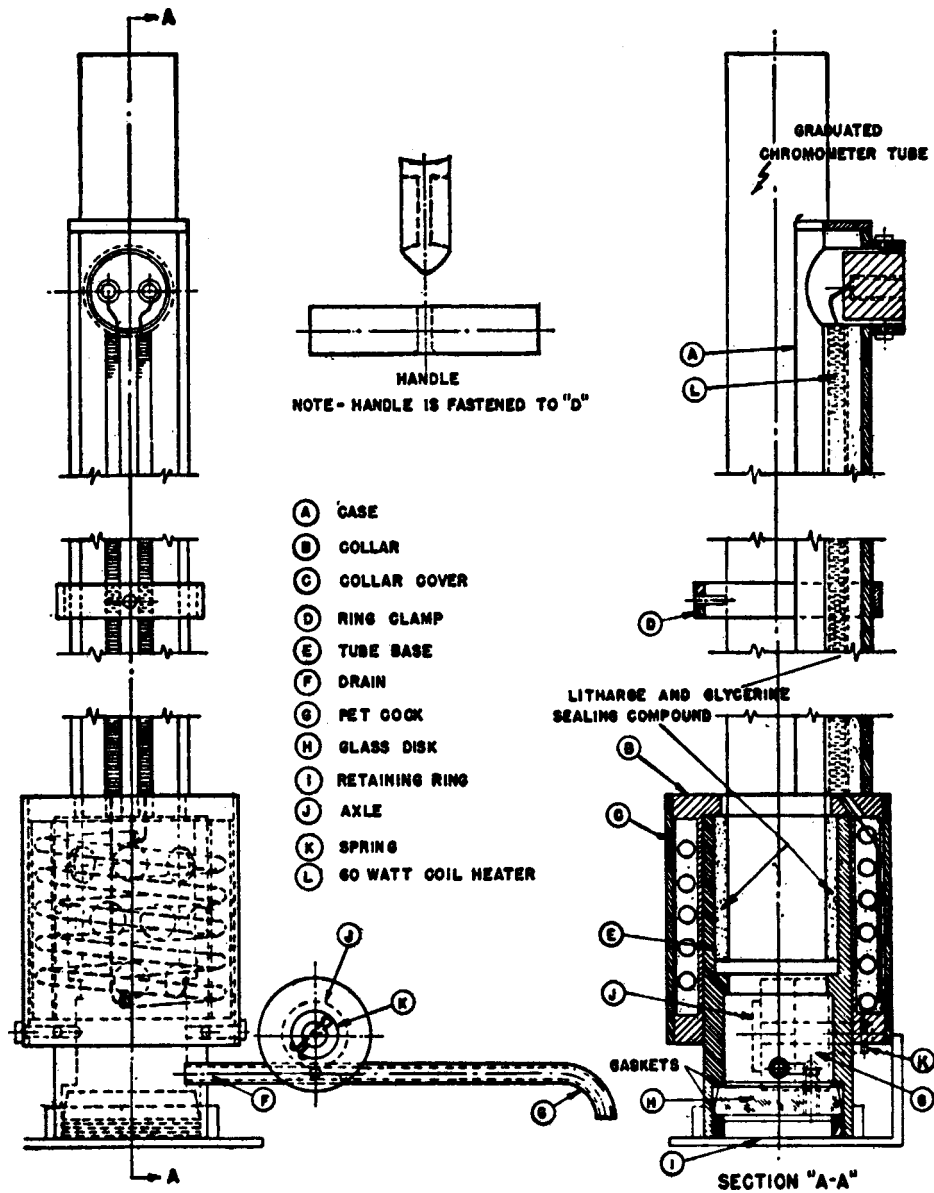

FIG. A1.2 Saybolt Chromometer Tube Heater

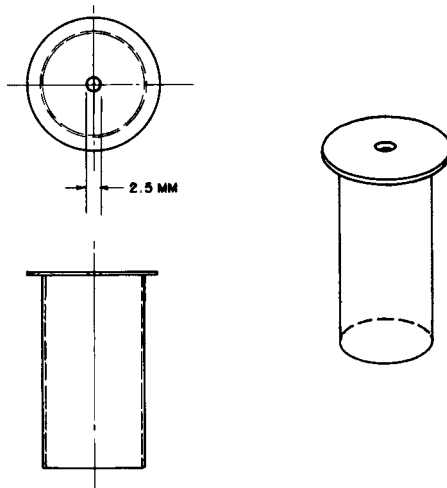

FIG. A1.3 Adapter

TABLE A1.1 Characteristics of Color Standards

Color Characteristics	Limits with:	
	Whole Color Standard	One-half Color Standard
T_w	0.860 to 0.865	0.888 to 0.891
x	0.342 to 0.350	0.327 to 0.331
y	0.367 to 0.378	0.344 to 0.350
z	0.272 to 0.291	0.319 to 0.330

TABLE A1.2 Characteristics of Daylight Filter

Color Characteristics	Limits
T_w	0.107 to 0.160
x	0.314 to 0.330
y	0.337 to 0.341
z	0.329 to 0.349

ICI International Commission on Illumination Standard Illuminant C,³ are as shown in **Table A1.1**. It is convenient, but not necessary, to mount the glasses in a turret within the collar mounted on the plain tube.

A1.3 Daylight Lamp

A1.3.1 *Lamp*—Use a lamp bulb rated at 60 W and conforming to the American Association of Lamp Manufacturers' specification 60A. It shall be constructed of clear glass, inside frost finish, and shall be rated at approximately 13 lm/W and 2750 K color temperature. Attach to a standard socket reflector, hemispherical in form, **Fig. A1.1**, the interior surface of which is finished with a brilliant aluminum bronze powder, free from mica and other adulterants, and applied with a heat-resistant bronzing liquid sprayed uniformly over the surface. This finish

shall be such as to be free from selective absorption, and have an initial reflectivity above 65 %.

A1.3.2 *Daylight Filter Glass* (**Note A1.2**), concave-convex in form, and dust-tight, shall fit closely over the opening in the hemispherical reflector, **Fig. A1.1**. The glass filter shall be finished on its concave surface by sandblasting and acid-smoothing or fortifying. An acceptable daylight filter shall possess such characteristics that the trilinear coordinates (x , y , and z), and the luminous transmission (T_w), when calculated from the spectral transmission data using the 1931 ICI Standard Illuminant A,³ are as shown in **Table A1.2**.

NOTE A1.2—A spectrophotometric test of an acceptable filter must indicate a transmission of radiant energy not less than 60 % at 410 nm, with a smooth curve down to a transmission below 10 percent at 700 nm. This curve furthermore, must not have the pronounced hump that is characteristic of excess cobalt. The typical cobalt curve has an increased transmission at a wavelength of 570 nm above a straight line drawn between the points 540 nm and 590 nm, and also a transmission band in the red for wavelengths of 600 nm and greater. This variation in an acceptable filter shall not, at 570 nm, exceed 0.03 above the straight line drawn between 540 nm and 590 nm, nor shall the transmission for wavelength 700 nm exceed the transmission for any shorter wavelength, such as 600 nm, by more than 0.03.

³ Judd, D. B., "The 1931 ICI Standard Observer and Coordinate System for Colorimetry," *Journal, Optical Soc. Am.*, JOSA, Vol 23, No. 10, October 1933, p. 359.

SUMMARY OF CHANGES

Subcommittee D02.05 has identified the location of selected changes to this standard since the last issue (D156–07) that may impact the use of this standard. (Approved Dec. 1, 2007.)

- (1) Updated definitions in **3.1.2-3.1.4**.
- (2) Updated **3.2.1** and added discussion.
- (3) Updated **5.1** and **9.1**.

Subcommittee D02.05 has identified the location of selected changes to this standard since the last issue (D156–02^{e1}) that may impact the use of this standard. (Approved July 15, 2007.)

- (1) Added **3.1**.
- (2) Added **9.1** and **9.2**.
- (3) Revised **9.3**.

ASTM International takes no position respecting the validity of any patent rights asserted in connection with any item mentioned in this standard. Users of this standard are expressly advised that determination of the validity of any such patent rights, and the risk of infringement of such rights, are entirely their own responsibility.

This standard is subject to revision at any time by the responsible technical committee and must be reviewed every five years and if not revised, either reapproved or withdrawn. Your comments are invited either for revision of this standard or for additional standards and should be addressed to ASTM International Headquarters. Your comments will receive careful consideration at a meeting of the responsible technical committee, which you may attend. If you feel that your comments have not received a fair hearing you should make your views known to the ASTM Committee on Standards, at the address shown below.

This standard is copyrighted by ASTM International, 100 Barr Harbor Drive, PO Box C700, West Conshohocken, PA 19428-2959, United States. Individual reprints (single or multiple copies) of this standard may be obtained by contacting ASTM at the above address or at 610-832-9585 (phone), 610-832-9555 (fax), or service@astm.org (e-mail); or through the ASTM website (www.astm.org).