



Standard Test Method for Flash Point by Tag Closed Cup Tester¹

This standard is issued under the fixed designation D56; the number immediately following the designation indicates the year of original adoption or, in the case of revision, the year of last revision. A number in parentheses indicates the year of last reapproval. A superscript epsilon (ϵ) indicates an editorial change since the last revision or reapproval.

This standard has been approved for use by agencies of the Department of Defense.

INTRODUCTION

To ensure an acceptable precision, this dynamic flash point test method employs a prescribed rate of temperature rise for the material under test. The rate of heating may not in all cases give the precision quoted in the test method because of the low thermal conductivity of certain materials. To improve the prediction of flammability, Test Method D3941, which utilizes a slower heating rate, was developed. Test Method D3941 provides conditions closer to equilibrium where the vapor above the liquid and the liquid are at about the same temperature. If a specification requires Test Method D56, do not change to Test Method D3941 or other test method without permission from the specifier.

Flash point values are a function of the apparatus design, the condition of the apparatus used, and the operational procedure carried out. Flash point can therefore only be defined in terms of a standard test method, and no general valid correlation can be guaranteed between results obtained by different test methods, or with test apparatus different from that specified.

1. Scope

1.1 This test method covers the determination of the flash point, by tag manual and automated closed testers, of liquids with a viscosity below 5.5 mm²/s (cSt) at 40°C (104°F), or below 9.5 mm²/s (cSt) at 25°C (77°F), and a flash point below 93°C (200°F).

1.1.1 For the closed-cup flash point of liquids with the following properties: a viscosity of 5.5 mm²/s (cSt) or more at 40°C (104°F); a viscosity of 9.5 mm²/s (cSt) or more at 25°C (77°F); a flash point of 93°C (200°F) or higher; a tendency to form a surface film under test conditions; or containing suspended solids, Test Method D93 can be used.

1.1.2 For cut-back asphalts refer to Test Methods D1310 and D3143.

NOTE 1—The U.S. Department of Transportation (RSTA)² and U.S. Department of Labor (OSHA) have established that liquids with a flash point under 37.8°C (100°F) are flammable as determined by this test

¹ This test method is under the jurisdiction of ASTM Committee D02 on Petroleum Products and Lubricants and is the direct responsibility of Subcommittee D02.08 on Volatility.

Current edition approved Oct. 1, 2010. Published November 2010. Originally approved in 1918. Last previous edition approved in 2005 as D56-05. DOI: 10.1520/D0056-05R10.

² For information on United States Department of Transportation regulations, see Codes of United States Regulation 49 CFR Chapter 1 and for information on United States Department of Labor regulations, see Code of United States Regulation 29 CFR Chapter XVII. Each of these items are revised annually and may be procured from the Superintendent of Documents, Government Printing Office, Washington, DC 20402.

method for those liquids that have a viscosity less than 5.5 mm²/s (cSt) at 40°C (104°F) or 9.5 mm²/s (cSt) or less at 25°C (77°F), or do not contain suspended solids or do not have a tendency to form a surface film while under test. Other flash point classifications have been established by these departments for liquids using this test method.

1.2 This test method can be used to measure and describe the properties of materials, products, or assemblies in response to heat and flame under controlled laboratory conditions and cannot be used to describe or appraise the fire hazard or fire risk of materials, products, or assemblies under actual fire conditions. However, results of this test method can be used as elements of fire risk assessment that takes into account all of the factors that are pertinent to an assessment of the fire hazard of a particular end use.

1.3 Related standards are Test Methods D93, D1310, D3828, D3278, and D3941.

1.4 The values stated in SI units are to be regarded as standard. The values given in parentheses are for information only.

1.5 **WARNING**—Mercury has been designated by many regulatory agencies as a hazardous material that can cause central nervous system, kidney and liver damage. Mercury, or its vapor, may be hazardous to health and corrosive to materials. Caution should be taken when handling mercury and mercury containing products. See the applicable product Material Safety Data Sheet (MSDS) for details and EPA's website—<http://www.epa.gov/mercury/faq.htm>—for additional information. Users should be aware that selling mercury

and/or mercury containing products into your state or country may be prohibited by law.

1.6 *This standard does not purport to address all of the safety concerns, if any, associated with its use. It is the responsibility of the user of this standard to establish appropriate safety and health practices and determine the applicability of regulatory limitations prior to use.* For specific warning statements see 8.2, 8.3, 9.5, 12.5, and refer to Material Safety Data Sheets.

2. Referenced Documents

2.1 ASTM Standards:³

D93 Test Methods for Flash Point by Pensky-Martens Closed Cup Tester

D1310 Test Method for Flash Point and Fire Point of Liquids by Tag Open-Cup Apparatus

D3143 Test Method for Flash Point of Cutback Asphalt with Tag Open-Cup Apparatus

D3278 Test Methods for Flash Point of Liquids by Small Scale Closed-Cup Apparatus

D3828 Test Methods for Flash Point by Small Scale Closed Cup Tester

D3941 Test Method for Flash Point by the Equilibrium Method With a Closed-Cup Apparatus

D4057 Practice for Manual Sampling of Petroleum and Petroleum Products

D6299 Practice for Applying Statistical Quality Assurance and Control Charting Techniques to Evaluate Analytical Measurement System Performance

D6300 Practice for Determination of Precision and Bias Data for Use in Test Methods for Petroleum Products and Lubricants

E1 Specification for ASTM Liquid-in-Glass Thermometers

E502 Test Method for Selection and Use of ASTM Standards for the Determination of Flash Point of Chemicals by Closed Cup Methods

2.2 Federal Test Method Standards:⁴

Method 1101, Federal Test Method Standard No. 791b

Method 4291, Federal Test Method Standard No. 141A

2.3 ISO Standards:⁵

Guide 34 General Requirements for the Competence of Reference Material Producers

Guide 35 Certification of Reference Materials—General and Statistical Principles

3. Terminology

3.1 Definitions:

3.1.1 *flash point*—the lowest temperature corrected to a pressure of 101.3 kPa (760 mm Hg) at which application of an ignition source causes the vapors of a specimen of the sample to ignite under specified conditions of test.

³ For referenced ASTM standards, visit the ASTM website, www.astm.org, or contact ASTM Customer Service at service@astm.org. For *Annual Book of ASTM Standards* volume information, refer to the standard's Document Summary page on the ASTM website.

⁴ Available from Superintendent of Documents, U.S. Government Printing Office, Washington, DC 20402.

⁵ Available from American National Standards Institute (ANSI), 25 W. 43rd St., 4th Floor, New York, NY 10036.

3.1.1.1 *Discussion*—The specimen is deemed to have flashed when a flame appears and instantaneously propagates itself over the entire surface of the fluid.

3.1.1.2 *Discussion*—When the ignition source is a test flame, the application of the test flame may cause a blue halo or an enlarged flame prior to the actual flash point. This is not a flash and should be ignored.

3.2 Definitions of Terms Specific to This Standard:

3.2.1 *dynamic (non-equilibrium)*—in this type of flash point apparatus, the condition of the vapor above the specimen and the specimen are not at the same temperature at the time that the ignition source is applied.

3.2.1.1 *Discussion*—This is primarily caused by the heating of the specimen at the constant prescribed rate with the vapor temperature lagging behind the specimen temperature. The resultant flash point temperature is generally within the reproducibility of the test method.

3.2.2 *equilibrium*—in that type of flash point apparatus or test method, the vapor above the specimen and the specimen are at the same temperature at the time the ignition source is applied.

3.2.2.1 *Discussion*—This condition may not be fully achieved in practice, since the temperature is not uniform throughout the specimen and the test cover and shutter are generally cooler.

4. Summary of Test Method

4.1 The specimen is placed in the cup of the tester and, with the lid closed, heated at a slow constant rate. An ignition source is directed into the cup at regular intervals. The flash point is taken as the lowest temperature at which application of the ignition source causes the vapor above the specimen to ignite.

5. Significance and Use

5.1 Flash point measures the tendency of the specimen to form a flammable mixture with air under controlled laboratory conditions. It is only one of a number of properties that shall be considered in assessing the overall flammability hazard of a material.

5.2 Flash point is used in shipping and safety regulations to define flammable and combustible materials. One should consult the particular regulation involved for precise definitions of these classes.

5.3 Flash point can indicate the possible presence of highly volatile and flammable materials in a relatively nonvolatile or nonflammable material. For example, an abnormally low flash point on a sample of kerosene can indicate gasoline contamination.

6. Apparatus (Manual Instrument)

6.1 *Tag Closed Tester*—The apparatus is shown in Fig. 1 and described in detail in Annex A1.

6.2 *Shield*—A shield 460 mm (18 in.) square and 610 mm (24 in.) high, open in front, is recommended.

6.3 *Temperature Measuring Device*—A liquid-in-glass thermometer, as prescribed in Table 1, or an electronic temperature measuring device such as a resistance device or thermocouple. The device shall exhibit the same temperature response as the liquid-in-glass thermometer.

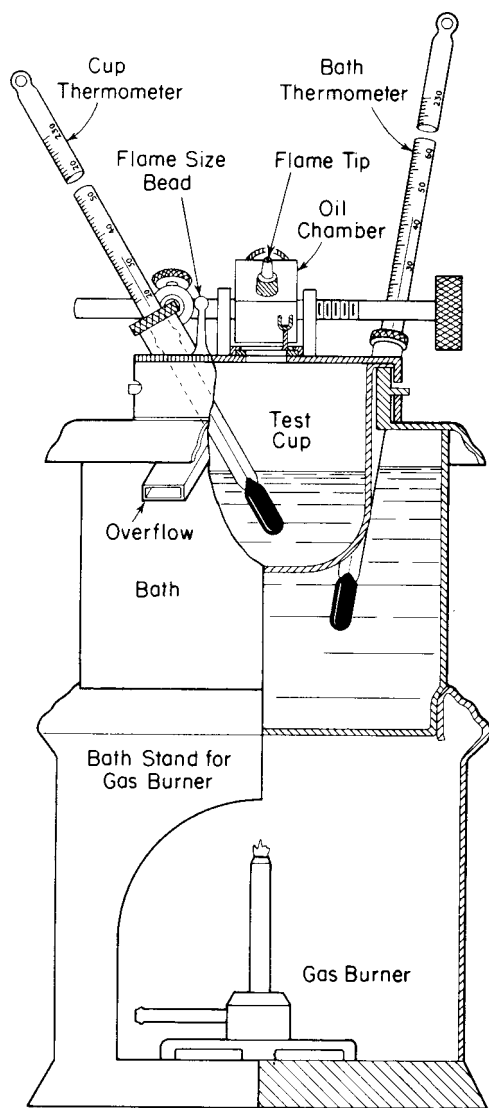

FIG. 1 Tag Closed Flash Tester (Manual)

TABLE 1 Thermometers

For tests	Below 4°C (40°F)	At 4 to 49°C (40 to 120°F)	Above 49°C (120°F)
Use ASTM Thermometer ^A	57C or (57F)	9C or (9F) 57C or (57F)	9C or (9F)

^A Complete specifications for these thermometers are given in Specification E1.

NOTE 2—Whenever thermometers complying with ASTM requirements are not available, thermometers complying with the requirements for The Institute of Petroleum thermometer IP 15C PM-Low can be used.

7. Sampling

7.1 Erroneously high flash points will be obtained when precautions are not taken to avoid the loss of volatile material. Containers should not be opened unnecessarily to prevent loss of volatile material and possible introduction of moisture. Transfers should not be made unless the sample temperature is at least 10°C (18°F) below the expected flash point. When possible, flash point shall be the first test performed on a sample and the sample must be stored at low temperature.

7.2 Do not store samples in gas-permeable containers since volatile materials may diffuse through the walls of the enclosure. Samples in leaky containers are suspect and not a source of valid results.

7.3 At least 50 mL of sample is required for each test. Refer to sampling information in Practice D4057.

8. Preparation of Apparatus (Manual)

8.1 Support the manual apparatus on a level steady surface, such as a table. Unless tests are made in a draft-free room or compartment, surround the tester on three sides by the shield for protection from drafts. Tests are not to be made in a laboratory draft hood or near ventilators.

8.2 Natural gas and bottled gas flame and electric ignitors have been found acceptable for use as the ignition source. (Warning—Gas pressure supplied to the apparatus must not be allowed to exceed 3 kPa (12 in.) of water pressure.)

8.3 For flash points below 13°C (55°F) or above 60°C (140°F), use as a bath liquid a 1 + 1 mixture of water and ethylene glycol (Warning—Ethylene Glycol—Poison. Harmful or fatal if swallowed. Vapor harmful. Avoid contact with skin.) For flash points between 13°C (55°F) and 60°C (140°F), either water or a water-glycol mixture can be used as bath liquid. The temperature of the liquid in the bath shall be at least 10°C (18°F) below the expected flash point at the time of introduction of the sample into the test cup. Do not cool bath liquid by direct contact with dry ice (solid carbon dioxide).

NOTE 3—Due to possible difficulty in maintaining the prescribed rate of temperature rise and due to the formation of ice on the lid, results by this test method for samples having flash points below 0°C (32°F) may be unreliable. Trouble due to ice formation on the slide can be minimized by carefully lubricating the slide shutter with high-vacuum silicone lubricant.

8.4 Verify the performance of the manual apparatus (or in 11.2.3, the automated apparatus) at least once per year by determining the flash point of a certified reference material (CRM), such as those listed in Annex A2, which is reasonably close to the expected temperature range of the samples to be tested. The material shall be tested according to the procedure of this test method and the observed flash point obtained in 9.5 shall be corrected for barometric pressure (see Section 13). The flash point obtained shall be within the limits stated in Table A2.1 for the identified CRM or within the limits calculated for an unlisted CRM (see Annex A2).

8.5 Once the performance of the apparatus has been verified, the flash point of secondary working standards (SWSs) can be determined along with their control limits. These secondary materials can then be utilized for more frequent performance checks (see Annex A2).

8.6 When the flash point obtained is not within the limits stated in 8.4 or 8.5, check the condition and operation of the apparatus to ensure conformity with the details listed in Annex A1, especially with regard to tightness of the lid (see A1.1.3), the action of the shutter, the position of the ignition source (see A1.1.3.3), and the angle and position of the temperature measuring device (see A1.1.3.4). After any adjustment, repeat the test in 8.4 using fresh test specimen, with special attention to the procedural details prescribed in the test method.

9. Procedure (Manual)

9.1 Using a graduated cylinder and taking care to avoid wetting the cup above the final liquid level, measure 50 ± 0.5 mL of the sample into the cup, both the sample and graduated cylinder being precooled, when necessary, so that the specimen temperature at the time of measurement will be $27 \pm 5^\circ\text{C}$ ($80 \pm 10^\circ\text{F}$) or at least 10°C (18°F) below the expected flash point, whichever is lower. It is essential that the sample temperature be maintained at least 10°C (18°F) below the expected flash point during the transfers from the sample container to the cylinder and from the cylinder to the test cup. Destroy air bubbles on the surface of the specimens by use of knife point or other suitable device. Wipe the inside of the cover with a clean cloth or absorbent tissue paper; then attach the cover, with the temperature measuring device in place, to the bath collar.

9.2 Light the test flame, when used, adjusting it to the size of the small bead on the cover. Operate the mechanism on the cover in such a manner as to introduce the ignition source into the vapor space of the cup, and immediately bring it up again. The time consumed for the full operation should be 1 s, allowing equal time periods for the introduction and return. Avoid any hesitation in the operation of depressing and raising the ignition source. When a flash is observed on the initial operation of the mechanism, discontinue the test and discard the result. In this case, a fresh sample shall be cooled an additional 10°C (18°F), below the original specimen installation temperature.

9.2.1 Exercise care when using a test flame, if the flame is extinguished it cannot ignite the specimen and the gas entering the vapor space can influence the result. When the flame is prematurely extinguished the test shall be discontinued and any result discarded.

9.3 *Flash Points Below 60°C (140°F)*—When the flash point of the sample is known to be below 60°C (140°F), apply and adjust the heat so that the temperature of the portion will rise at a rate of 1°C (2°F)/min ± 6 s. When the temperature of the specimen in the test cup is 5°C (10°F) below its expected flash point, apply the ignition source in the manner just described in 9.2 and repeat the application of the ignition source after each 0.5°C (1°F) rise in temperature of the specimen.

9.4 *Flash Points at 60°C (140°F) or Above*—If the flash point of the sample is known to be 60°C (140°F) or higher, apply and adjust the heat so that the temperature of the specimen will rise at a rate of 3°C (5°F)/min ± 6 s. When the temperature of the specimen in the test cup is 5°C (10°F) below its expected flash point, apply the ignition source in the manner just described in 9.2 and repeat the application of the ignition source each 1°C (2°F) rise in temperature of the specimen.

9.5 When the application of the ignition source causes a distinct flash in the interior of the cup, as defined in 3.1.1, observe and record the temperature of the specimen as the flash point. Do not confuse the true flash with the bluish halo that sometimes surrounds the ignition source during applications immediately preceding the actual flash. (**Warning**—For certain mixtures containing halogenated hydrocarbons, such as, methylene chloride or trichloroethylene, no distinct flash, as

defined, is observed. Instead a significant enlargement of the test flame (not halo effect) and change in color of the test flame from blue to yellowish-orange occurs. Continued heating and testing of these samples above ambient temperature can result in significant burning of vapors outside the test cup, and can be a potential fire hazard. See [Appendix X1](#) and [Appendix X2](#) for more information.)

9.6 Discontinue the test and remove the source of heat. Lift the lid and wipe the temperature measuring device bulb. Remove the test cup, empty, and wipe dry.

9.7 If, at any time between the first introduction of the ignition source and the observation of the flash point, the rise in temperature of the specimen is not within the specified rate, discontinue the test, discard the result and repeat the test, adjusting the source of heat to secure the proper rate of temperature rise, or using a modified “expected flash point,” or both, as required.

9.8 Never make a repeat test on the same specimen of sample; always take fresh specimen of sample for each test.

10. Apparatus (Automated Instrument)

10.1 An automated flash point instrument is used that is capable of performing the test in accordance with Section 9. The apparatus can use a gas test flame or electric ignitor. The dimensions for the test cup and test cover are shown in [Fig. A1.1](#) and [Fig. A1.2](#).

10.2 Samples with low flash point may require a source of cooling for the heating area.

11. Preparation of Apparatus (Automated Instrument)

11.1 Support the automated apparatus on a level, steady surface, such as a table. Unless tests are made in a draft-free compartment, it is a good practice, but not required, to surround the tester with a shield to prevent draft.

11.2 The user of the automatic instrument must be sure that all of the manufacturer’s instructions for calibrating, checking, and operating the equipment are followed.

11.2.1 Adjust the detection system per manufacturer’s instructions.

11.2.2 Calibrate the temperature measuring device per manufacturer’s instructions.

11.2.3 Verify the performance of the automated apparatus at least once per year by determining the flash point of a certified reference material (CRM) such as those listed in [Annex A2](#), which is reasonably close to the expected temperature range of the samples to be tested. The material shall be tested according to the procedure of this test method and the observed flash point obtained in 9.5 shall be corrected for barometric pressure (see Section 13). The flash point obtained shall be within the limits stated in [Table A2.1](#) for the identified CRM or within the limits calculated for an unlisted CRM (see [Annex A2](#)).

11.2.4 Once the performance of the apparatus has been verified, the flash point of secondary working standards (SWSs) can be determined along with their control limits. These secondary materials can then be utilized for more frequent performance checks (see [Annex A2](#)).

11.2.5 When the flash point obtained is not within the limits stated in 11.2.3 or 11.2.4, check the condition and operation of the apparatus to ensure conformity with the details listed in

Annex A1, especially with regard to tightness of the lid (see **A1.1.3**), the action of the shutter, the position of the ignition source (see **A1.1.3.3**), and the angle and position of the temperature measuring device (see **A1.1.3.4**). After any adjustment, repeat the test in **11.2.3** using fresh test specimen, with special attention to the procedural details prescribed in the test method.

12. Procedure (Automated)

12.1 Adjust the external cooling system, if required, to a temperature necessary to cool the heating area 10°C below the expected flash point.

12.2 Place the test cup in position in the instrument.

12.3 Enter the Expected Flash Point; this will allow the heating area to be cooled to the required minimum starting temperature.

NOTE 4—To avoid an abnormal heating rate when the specimen is at a low temperature, it is recommended to precool the test cup and cover. This may be accomplished by placing the assembly into position in the instrument while it is cooling to 10°C (18°F) below the programmed Expected Flash Point.

NOTE 5—Flash Point results determined in an “unknown Expected Flash Point mode” should be considered approximate. This value can be used as the Expected Flash Point when a fresh specimen is tested in the standard mode of operation.

12.4 Using a graduated cylinder and taking care to avoid wetting the cup above the final liquid level, measure 50 ± 0.5 mL of the sample into the cup, both the sample and the graduated cylinder being precooled, when necessary, so that the specimen temperature at the time of the measurement is 27 ± 5°C (80 ± 10°F) or at least 10°C (18°F) below the expected flash point, whichever is lower. It is essential that the sample temperature be maintained at least 10°C (18°F) below the expected flash point during the transfers from the sample container to the cylinder and from the cylinder to the test cup. Destroy air bubbles on the surface of the specimen by use of knife point or other suitable device. Wipe the inside of the cover with a clean cloth or absorbent tissue paper; then attach the cover, with the temperature measuring device in place, to the bath collar. Connect the shutter and ignition source activator, if so equipped, into the lid housing. When using a gas test flame, light the pilot flame and adjust the test flame to 4 mm ($\frac{5}{32}$ in.) in diameter. If the instrument is equipped with an electrical ignition device, adjust according to the manufacturer’s instructions. Test the ignition source dipping action, if so equipped, and observe if the apparatus functions correctly. Press the start key. If a flash is observed upon initial operation, discontinue the test and discard the result. In this case a fresh specimen shall be cooled to an additional 10°C (18°F) below the original specimen installation temperature.

NOTE 6—Care should be taken when cleaning and positioning the lid assembly so as not to damage or dislocate the flash detection system or temperature measuring device. See manufacturer’s instructions for proper care and maintenance.

12.5 The apparatus shall automatically control the test procedure as described in this test method. When the flash point is detected, the apparatus will record the temperature and automatically discontinue the test. If a flash is detected on the first application, the test should be discontinued, the result shall

be discarded and the test repeated with a fresh specimen. (**Warning**—For certain mixtures containing halogenated hydrocarbons, such as, methylene chloride or trichloroethylene, no distinct flash, as defined, is observed. Instead a significant enlargement of the test flame (not halo effect) and change in color of the test flame from blue to yellowish-orange occurs. Continued heating and testing of these samples above ambient temperature can result in significant burning of vapors outside the test cup, and can be a potential fire hazard. See **Appendix X1** and **Appendix X2** for more information.)

12.6 When the apparatus has cooled down to a safe handling temperature (less than 55°C (130°F)) remove the cover and the test cup and clean the apparatus as recommended by the manufacturer.

13. Report

13.1 Correction for barometric pressure. Observe and record the ambient barometric pressure at the time and place of the test. When the pressure differs from 101.3 kPa (760 mm Hg), correct the flash point as follows:

$$\text{Corrected flash point} = C + 0.25 (101.3 - p) \quad (1)$$

$$\text{Corrected flash point} = F + 0.06 (760 - P) \quad (2)$$

$$\text{Corrected flash point} = C + 0.033 (760 - P) \quad (3)$$

where:

C = observed flash point, °C,

F = observed flash point, °F,

p = ambient barometric pressure, kPa, and

P = ambient barometric pressure, mm Hg.

13.2 The barometric pressure used in this calculation shall be the ambient pressure for the laboratory at the time of test. Many aneroid barometers, such as those used at weather stations and airports, are precorrected to give sea level readings; these shall not be used.

13.3 Report the corrected flash point to the nearest 0.5°C (or 1°F).

14. Precision and Bias

14.1 *Precision*—The following criteria shall be used for judging the acceptability of results (95 % probability):

14.1.1 *Repeatability*—The difference between successive test results, obtained by the same operator with the same apparatus under constant operating conditions on identical test material, would in the long run, in the normal and correct operation of the test method, exceed the following values only in one case in twenty:

Flash Point, °C (°F)	Repeatability, °C (°F)
Below 60°C (140°F)	1.2°C (2.0°F)
At and Above 60°C (140°F)	1.6°C (3.0°F)

14.1.2 *Reproducibility*—The difference between two single and independent results, obtained by different operators working in different laboratories on identical test material, would in the long run, in the normal and correct operation of the test method, exceed the following values only in one case in twenty:

Flash Point, °C (°F)

Reproducibility, °C (°F)

Below 60°C (140°F)

4.3°C (8°F)

At and Above 60°C (140°F)

5.8°C (10°F)

14.2 *Bias*—The procedure in Test Method D56 for measuring flash point has no bias since the tag flash point can be defined only in terms of this test method. The current inter-laboratory tests confirm that there is no relative bias between manual and automated procedures. In any case of dispute the flash point as determined by the manual procedure shall be considered the referee test.

NOTE 7—Mixtures such as, but not limited to, those that are chlorinated or include water may cause significant differences in the results obtained by manual and automatic instruments. For these mixtures, the precision statement may not apply.

NOTE 8—The precision data were developed in a 1991 cooperative test program⁶ using eight (8) samples. Twelve (12) laboratories participated with the manual apparatus and seventeen (17) laboratories participated with the automatic equipment. Information on the type of samples and their average flashpoints are in the research report.

15. Keywords

15.1 combustible; fire risk; flammable; flash point; tag closed cup

⁶ Supporting data have been filed at ASTM International Headquarters and may be obtained by requesting Research Report RR:S15-1007.

ANNEXES

(Mandatory Information)

A1. APPARATUS

A1.1 Tag Closed Tester

A1.1.1 The Tag Closed Tester shall consist of the test cup, lid with ignition source, and liquid bath conforming to the following requirements:

A1.1.2 *Test Cup*, of brass or other nonrusting metal of equivalent heat conductivity, conforming to dimensional requirements prescribed in Fig. A1.1.

A1.1.3 Lid:

A1.1.3.1 The lid comprises a circle of nonrusting metal with a rim projecting downward about 15.9 mm (⁵/₈ in.), a slide shutter, a device which simultaneously opens the shutter and depresses the ignition source, and a slanting collar in which the cup-temperature measuring device ferrule is inserted. Fig. A1.2 gives a diagram of the upper surface of the lid, showing dimensions and positions of the three holes opened and closed by the shutter, and the size and position of the opening for the cup temperature measuring device.

A1.1.3.2 The rim shall fit the collar of the liquid bath with a clearance not exceeding 0.4 mm (0.002 in.) and shall be slotted in such a manner as to press the lid firmly down on the top of the cup when the latter is in place in the bath. When this requirement is not met, the vertical position of the cup in the bath shall be suitably adjusted, as by placing a thin ring of metal under the flange of the cup.

A1.1.3.3 The shutter shall be of such size and shape that it covers the three openings in the lid when in the closed position and uncovers them completely when in the open position. The nozzle of the flame-exposure device, when used, shall conform to the dimensions given in Table A1.1. The ignition source

device shall be designed and constructed so that opening the shutter depresses the tip to a point approximately 2 mm (0.08 in.) to the right of the horizontal center of the middle opening of the lid (refer to lower part of Fig. A1.3). This will bring the ignition source to the approximate center of the opening. The plane of the underside of the lid shall be between the top and bottom of the tip of the ignition source when the latter is fully depressed.

A1.1.3.4 The collar for the cup-temperature measuring device ferrule shall be set at an angle that permits placement of the temperature measuring device with its bulb approximately in the horizontal center of the cup, at a depth prescribed in Table A1.1.

A1.1.4 *Liquid Bath*, conforming to the limiting or minimum dimension shown in Fig. A1.3. It shall be of brass, copper, or other noncorroding metal of substantial construction. Sheet metal of about No. 20 B&S gage (0.812 mm) is satisfactory. It may, if desired, be lagged with heat-insulating material to facilitate control of temperature.

A1.1.5 *Heater*, of any type (electric, gas, alcohol, and so forth) capable of controlling temperature as required in Section 9. An external electric heater, controlled by a variable voltage transformer, is recommended.

A1.1.6 *Bath Stand*—For electric heating, any type of stand may be used. For alcohol lamp or gas burner, a stand, as illustrated in Fig. 1, to protect the ignition source from air currents (unless tests can be made in a draft-free room) is required.

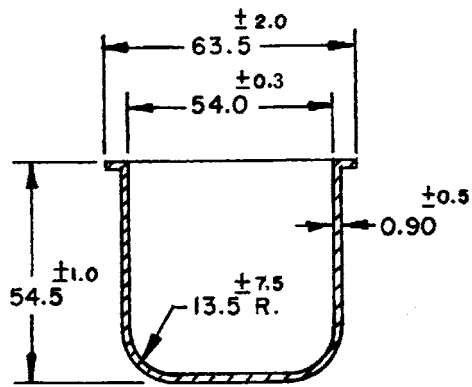
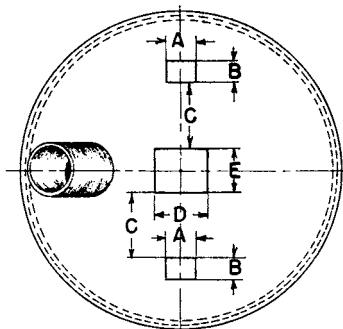
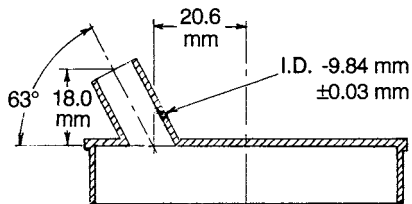

FIG. A1.1 Specimen Cup



- A — 7.15 mm
- B — 4.78 mm
- C — 15.10 mm
- D — 11.92 mm
- E — 10.32 mm

Note: All dimensions ± 0.13 mm unless otherwise shown.



Inch-Pound Equivalents			
mm	in.	mm	in.
0.03	0.001	10.32	0.406
0.13	0.005	11.92	0.469
4.78	0.188	15.10	0.594
7.15	0.281	18.0	0.71
9.84	0.387	20.6	0.81

NOTE—Dimensions relating to the size and position of the temperature measuring device collar are recommended but not mandatory.

FIG. A1.2 Top of Lid Showing Position and Dimensions of Openings

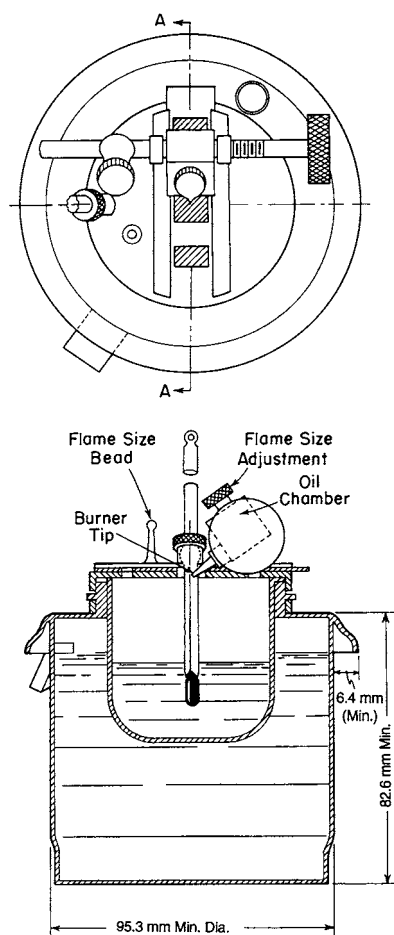

Inch-Pound Equivalents

mm	in.
6.4	0.25
82.6	3.25
95.3	3.75

FIG. A1.3 Section of Liquid Bath and Test Cup (Manual Apparatus)

TABLE A1.1 Dimensional Requirements

Depth of bath liquid surface below top of test cup	27.8 ± 0.4 mm (1.094 ± 0.016 in.)
Depth of sample surface below top of test cup	29.4 ± 0.8 mm (1.156 ± 0.031 in.)
Depth of bottom of bulb of test temperature measuring device below top of cup when in place	45.0 ± 0.8 mm (1.77 ± 0.031 in.)
Inside diameter of specimen cup	54.0 ± 0.3 mm (2.125 ± 0.010 in.)
Diameter of bead on top of cover	4.0 ± 0.8 mm (0.156 ± 0.031 in.)
Diameter of opening in tip of test flame nozzle	1.2 ± 0.3 mm (0.049 ± 0.010 in.)
Outside diameter of tip of test flame nozzle	2.0 mm max (0.079 in. max)

A2. VERIFICATION OF APPARATUS PERFORMANCE

A2.1 *Certified Reference Material (CRM)*—CRM is a stable, pure (99 + mol % purity) hydrocarbon or other stable petroleum product with a method-specific flash point established by a method-specific interlaboratory study following Practice D6300 (formerly known as ASTM RR:D02-1007 guidelines) or ISO Guide 34 and 35.

A2.1.1 Typical values of the flash point corrected for barometric pressure for some reference materials and their typical limits are given in Table A2.1 (see Note A2.2). Suppliers of CRM's will provide certificates stating the method-specific flash point for each material of the current production batch. Calculation of the limits for these other

TABLE A2.1 D56 Typical Flash Point Values and Typical Limits for CRM

Hydrocarbon	Purity (mole %)	Flash Point(°C)	Limits (°C)
n-decane	99+	50.9	±2.3
n-undecane	99+	67.1	±2.3

CRM's can be determined from the reproducibility value of this test method, reduced by interlaboratory effect and then multiplied by 0.7 (see Research Report RR:S15-1007⁶).

NOTE A2.1—Supporting data for the interlaboratory study to generate the flash point in Table A2.1 can be found in research report RR:S15-1010.⁷

⁷ Supporting data have been filed at ASTM International Headquarters and may be obtained by requesting Research Report RR:S15-1010.

NOTE A2.2—Materials, purities, flash point values and limits stated in Table A2.1 were developed in an ASTM interlaboratory program (see RR:S15-1010⁷) to determine suitability of use for verification fluids in flash point test methods. Other materials, purities, flash point values and limits can be suitable when produced according to the practices of Practice D6300 (formerly known as ASTM RR:D02-1007 guidelines) or ISO Guides 34 and 35. Certificates of performance of such materials should be consulted before use, as the flash point value will vary dependent on the composition of each CRM batch.

NOTE A2.3—p-Xylene obtained from any reputable chemical supplier may be used as calibrating fluid as long as it meets the specifications detailed in A2.1.1.

A2.2 *Secondary Working Standard (SWS)*—SWS is a stable, pure (99 + mol % purity) hydrocarbon, or other petroleum product with composition known to remain appreciably stable.

A2.2.1 Establish the mean flash point and the statistical control limits (3σ) for the SWS using standard statistical techniques. See Practice D6299.

A3. MANUFACTURING STANDARDIZATION

A3.1 The cup temperature measuring device, which conforms also to the specifications for the low-range temperature measuring device used in the Pensky-Martens flash tester, Test Method D93, is frequently supplied by the temperature measuring device manufacturer with a metal or polytetrafluoroethylene ferrule intended to fit the collar on the lid of the flash tester. This ferrule is frequently supplemented by an adapter that is used in the larger-diameter collar of the Pensky-Martens apparatus. Differences in dimensions of these collars, which are immaterial in their effect on the result of tests, are a source

of considerable unnecessary trouble to manufacturers and suppliers of instruments as well as to users.

A3.2 Subcommittee E01.21 on Reference Material Planning, Proficiency Testing, and Laboratory Accreditation, has studied this problem and has established some dimensional requirements which are shown, suitably identified, in Fig. A1.1, Fig. A3.1, and Fig. A3.2. Conformity to these requirements is not mandatory but is desirable to users as well as suppliers of tag closed testers.

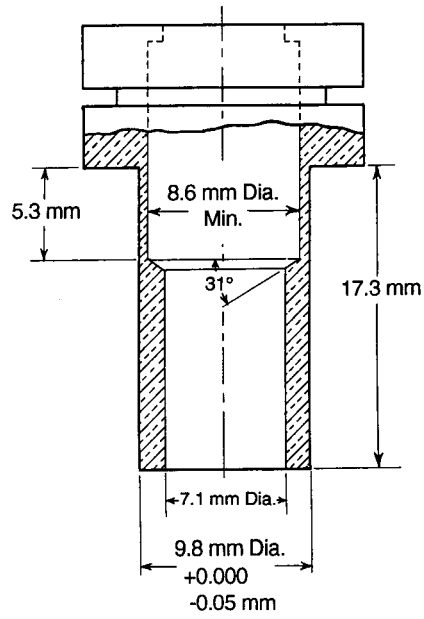

Inch-Pound Equivalents

mm	in.	mm	in.
0.05	0.002	8.6	0.34
5.3	0.21	9.8	0.385
7.1	0.28	17.3	0.68

FIG. A3.1 Dimensions for Temperature Measuring Device Ferrule (Not Mandatory)

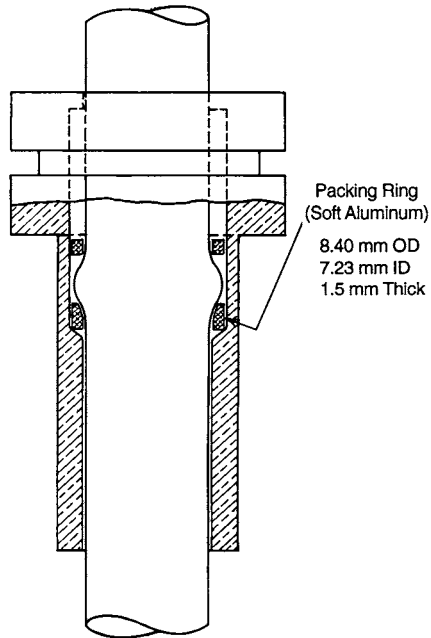

Inch-Pound Equivalents

mm	in.
1.5	0.06
7.23	0.284
8.40	0.330

FIG. A3.2 Dimensions for Temperature Measuring Device Packing Ring (Not Mandatory)

APPENDIXES

(Nonmandatory Information)

X1. FLASH POINT MASKING PHENOMENON

X1.1 A condition during flash point testing can occur with certain mixtures whereby the nonflammable component of the sample tends to inert the vapor space above the liquid, thus preventing a flash. Under this condition, the flash point of the material is masked resulting in the reporting of incorrect high flash point or no flash point.

X1.2 This flash point masking phenomenon most frequently occurs with ignitable liquids that contain certain halogenated hydrocarbons such as dichloromethane (methylene chloride) and trichloroethylene.

X1.3 Under this condition, no distinct flash as defined in 3.1.1 is observed. Instead a significant enlargement of the test

flame and a change in the color of the test flame from blue to yellow-orange laminar flame is observed.

X1.4 Under this condition, continued heating and testing for flash point at temperatures above ambient temperature, have resulted in significant burning of the ignitable vapor outside the test cup, often above the test flame. This can be a potential fire hazard if not recognized.

X1.5 It is recommended that if this condition is encountered during the flash point testing of these type of materials, testing should be discontinued.

X1.6 Further commentaries regarding flash point test and flammability of mixtures can be found in Test Method E502.

X2. FLASH POINT TEST AND FLAMMABILITY OF MIXTURES

X2.1 While the flash point can be used to indicate the flammability of liquid materials for certain end uses, flash point does not represent the minimum temperature at which a material can evolve flammable vapors.

X2.2 There are instances with pure materials where the absence of a flash point does not ensure freedom from flammability. Included in this category are materials that require large diameters for flash propagation, such as trichloroethylene. This material will not propagate a flame in apparatus the size of a flash point tester, however, its vapors are flammable and will burn when ignited in apparatus of adequate size.

X2.3 When a liquid contains flammable and nonflammable

components, there are cases where this liquid can evolve flammable vapors under certain conditions and yet will not exhibit a close-cup flash point. This phenomenon is noted when a nonflammable component is sufficiently volatile and present in sufficient quantity to inert the vapor space of the closed cup, thus preventing a flash. In addition, there are certain instances where an appreciable quantity of the nonflammable component will be present in the vapor, and the material will exhibit no flash point.

X2.4 Liquids containing a highly volatile nonflammable component or impurity, which exhibit no flash point because of the influence of the nonflammable material, may form flammable mixtures if totally flash vaporized in air in the proper proportions.

ASTM International takes no position respecting the validity of any patent rights asserted in connection with any item mentioned in this standard. Users of this standard are expressly advised that determination of the validity of any such patent rights, and the risk of infringement of such rights, are entirely their own responsibility.

This standard is subject to revision at any time by the responsible technical committee and must be reviewed every five years and if not revised, either reapproved or withdrawn. Your comments are invited either for revision of this standard or for additional standards and should be addressed to ASTM International Headquarters. Your comments will receive careful consideration at a meeting of the responsible technical committee, which you may attend. If you feel that your comments have not received a fair hearing you should make your views known to the ASTM Committee on Standards, at the address shown below.

This standard is copyrighted by ASTM International, 100 Barr Harbor Drive, PO Box C700, West Conshohocken, PA 19428-2959, United States. Individual reprints (single or multiple copies) of this standard may be obtained by contacting ASTM at the above address or at 610-832-9585 (phone), 610-832-9555 (fax), or service@astm.org (e-mail); or through the ASTM website (www.astm.org). Permission rights to photocopy the standard may also be secured from the ASTM website (www.astm.org/COPYRIGHT/).