



Designation: D1403 – 10



Designation: 310/84 (92)

Standard Test Methods for Cone Penetration of Lubricating Grease Using One-Quarter and One-Half Scale Cone Equipment¹

This standard is issued under the fixed designation D1403; the number immediately following the designation indicates the year of original adoption or, in the case of revision, the year of last revision. A number in parentheses indicates the year of last reapproval. A superscript epsilon (ϵ) indicates an editorial change since the last revision or reapproval.

This standard has been approved for use by agencies of the Department of Defense.

1. Scope*

1.1 These test methods cover two procedures for measuring the consistency of small samples of lubricating greases by penetration of a 1/4-scale cone or a 1/2-scale cone. These test methods include procedures for the measurement of unworked and worked penetrations.

1.2 Unworked penetrations do not generally represent the consistency of greases in use as effectively as do worked penetrations. The latter are usually preferred for inspecting lubricating greases.

1.3 The values in SI units are to be regarded as the standard. The values given in parentheses are for information only. In the United States, the equipment dimensions stated in inches are to be regarded as the standard.

1.4 *This standard does not purport to address all of the safety concerns, if any, associated with its use. It is the responsibility of the user of this standard to establish appropriate safety and health practices and determine the applicability of regulatory limitations prior to use.*

2. Referenced Documents

2.1 *ASTM Standards:*²

D217 Test Methods for Cone Penetration of Lubricating Grease

D4175 Terminology Relating to Petroleum, Petroleum Products, and Lubricants

¹ These test methods are under the jurisdiction of ASTM Committee D02 on Petroleum Products and Lubricants and is the direct responsibility of Subcommittee D02.G0.02 on Consistency and Related Rheological Tests.

In the IP, this test method is under the jurisdiction of the Standardization Committee. This test method has been approved by the sponsoring committee and accepted by the cooperating societies in accordance with established procedures.

Current edition approved May 1, 2010. Published June 2010. Originally approved in 1956. Last previous edition approved in 2007 as D1403-02(2007). DOI: 10.1520/D1403-10.

² For referenced ASTM standards, visit the ASTM website, www.astm.org, or contact ASTM Customer Service at service@astm.org. For *Annual Book of ASTM Standards* volume information, refer to the standard's Document Summary page on the ASTM website.

2.2 *Energy Institute Standard:*³

IP 50 Method of Testing for Cone Penetration of Lubricating Grease

3. Terminology

3.1 *Definitions:*

3.1.1 *consistency, n*—of lubricating grease, the degree of resistance to movement under stress.

3.1.1.1 *Discussion*—The term consistency is used somewhat synonymously with penetration. Generally, consistency refers to the worked penetration of a grease. **D217**

3.1.2 *lubricant, n*—any material interposed between two surfaces that reduces the friction or wear between them. **D4175**

3.1.3 *lubricating grease, n*—a semi-fluid to solid product of a dispersion of a thickener in a liquid lubricant.

3.1.3.1 *Discussion*—The dispersion of the thickener forms a two-phase system and immobilizes the liquid lubricant by surface tension and other physical forces. Other ingredients imparting special properties are often included. **D217**

3.1.4 *penetrometer, n*—an instrument that measures the consistency or hardness of semiliquid to semisolid materials by measuring the depth to which a specified cone or needle under a given force falls into the material.

3.1.4.1 *Discussion*—In these test methods, either a one-quarter scale cone (A1.1) or a one-half scale cone (A1.3) can be used to determine the consistency of lubricating greases. The penetration forces are determined by the respective masses of the cones and shafts.

3.1.5 *thickener, n*—in lubricating grease, a substance composed of finely divided particles dispersed in a liquid lubricant to form the product's structure.

3.1.5.1 *Discussion*—The thickener can be fibers (such as various metallic soaps) or plates or spheres (such as certain non-soap thickeners) which are insoluble or, at the most, only

³ Available from Energy Institute, 61 New Cavendish St., London, WIG 7AR, U.K., <http://www.energyinst.org.uk>.

*A Summary of Changes section appears at the end of this standard.

very slightly soluble in the liquid lubricant. The general requirements are that the solid particles be extremely small, uniformly dispersed, and capable of forming a relatively stable, gel-like structure with the liquid lubricant. **D217**

3.2 Definitions of Terms Specific to This Standard:

3.2.1 *penetration, n*—of lubricating grease, the depth in units of 0.1 mm that a ¼-scale cone or ½-scale cone penetrates the sample when released to fall under its own weight for 5 s.

3.2.1.1 *Discussion*—The term penetration used in these test methods is similar to that found in Test Methods **D217**. Due to the differences in scale, the terms are not synonymous and should not be confused.

3.2.2 *penetrometer, n*—an instrument similar to that shown in Fig. 1 of Test Methods **D217**, designed to measure the depth to which the ¼-scale or the ½-scale cone falls into grease.

3.2.3 *unworked penetration, n*—the penetration at 25°C (77°F) of a sample of lubricating grease that has received only minimum disturbance in transfer to a ¼-scale or ½-scale grease worker cup or dimensionally equivalent rigid container.

3.2.4 *worked penetration, n*—the penetration of a sample of lubricating grease that has been brought to 25°C (77°F), subjected to 60 double strokes in a ¼-scale or ½-scale grease worker, and penetrated without delay.

3.2.5 *working, v*—the subsection of a lubricating grease to the shearing action of the ¼-scale or ½-scale grease worker.

4. Summary of Test Method

4.1 The penetration is determined at $25 \pm 0.5^\circ\text{C}$ ($77 \pm 1^\circ\text{F}$) by releasing the ¼-scale or ½-scale cone assembly from the penetrometer and allowing the cone to drop freely into the grease for 5 ± 0.1 s.

5. Significance and Use

5.1 These test methods are applicable to greases of National Lubricating Grease Institute (NLGI) consistency numbers 0 to 4 and is intended for use only where the size of the sample prevents the use of Test Methods **D217**.

5.2 Actual reduced-scale penetration values are not used or reported. They are converted to full-scale penetration values (see Sections 9 and 10). This test method is not intended to replace the full-scale penetration as described in Test Methods **D217**. Precision is better in the full-scale penetration method.

5.3 Worked penetration results, after conversion to full-scale values, may be used to establish the consistency of lubricating greases within the above NLGI consistency numbers. The results obtained from these test methods are widely used for specification purposes, however, no correlation with field performance has been established.

5.4 Unworked penetration results provide a means of evaluating the effect of storage conditions on grease consistency.

6. Apparatus

6.1 *Penetrometer*—An instrument similar to that shown in Fig. 1 of Test Methods **D217**, adapted for use with the ¼-scale or ½-scale cone.

NOTE 1—Any slight binding in the instrument may produce a significant error in penetration values. Periodic check of the release mechanism, cone dimensions, and weights of cone and its movable attachments is recommended.

6.2 ¼ -Scale Cone and Shaft, as specified in **A1.1**.

6.3 ¼ -Scale Grease Worker, as specified in **A1.2**.

6.4 ½ -Scale Cone and Shaft, as specified in **A1.3**.

6.5 ½ -Scale Grease Worker, as specified in **A1.4**.

6.6 *Temperature Bath*, capable of controlling the bath temperature at $25 \pm 0.5^\circ\text{C}$ ($77 \pm 1^\circ\text{F}$) and designed to bring the assembled grease worker to test temperature conveniently. Examples of suitable temperature baths include a water bath, air bath, constant temperature test room, or a temperature-controlled metal block. If a water bath is to be used for samples for unworked penetration, means should be provided for protecting the grease surface from water and for maintaining the air above the sample at test temperature. An air bath is preferred for bringing block greases to test temperature, but a tightly sealed container placed in a water bath will suffice.

6.7 *Spatula*, corrosion-resistant, having a stiff blade approximately 13 mm (0.5 in.) wide and convenient in length.

7. Procedure for Unworked Penetration

7.1 *Sample*—Sufficient sample to overfill the cup of the grease worker is required. Three measurements can be obtained from one filling of the grease cup, by replacement of grease lost to the cone and repairing of the grease surface.

7.2 *Preparing Sample for Measurement*—Place the empty grease worker cup and an appropriate amount of the sample in a container in the temperature bath maintained at $25 \pm 0.5^\circ\text{C}$ ($77 \pm 1^\circ\text{F}$) for sufficient time to bring the temperature of the sample and the worker cup to $25 \pm 0.5^\circ\text{C}$ ($77 \pm 1^\circ\text{F}$). Transfer the sample, preferably in one lump, to overfill the cup of the grease worker. Make this transfer in such a manner that the grease will be worked as little as possible. Jar the cup to drive out trapped air and pack the grease with the spatula, with as little manipulation as possible to fill the cup without air pockets. Scrape off the excess grease extending above the rim, creating a flat surface, by moving the blade of the spatula, held inclined toward the direction of motion at an angle of approximately 45° , across the rim of the cup, retaining the portion removed. Do not perform any further leveling or smoothing of the surface throughout the determination of unworked penetration and determine the measurement immediately.

NOTE 2—The jarring should be as vigorous as required to remove the entrapped air without splashing the specimen from the cup. In performing these operations, a minimum of manipulation should be used, as any agitation of the grease can have the effect of applying some working effect on the unworked grease and affecting the result.

NOTE 3—Retain the grease removed from the cup in scraping for subsequent tests. Keep the outside of the rim of the cup clean so that the grease forced by the penetrometer cone to overflow the cup can be returned to the cup prior to preparing the specimen for the next test.

7.3 *Cleaning Cone and Shaft*—Clean the penetrometer cone carefully before each test. Bending of the cone shaft can be avoided by holding it securely in its raised position while cleaning. Do not permit grease or oil on the penetrometer shaft, as they can cause drag on the shaft assembly. Do not rotate the cone, as this can cause wear on the release mechanism.

7.4 *Penetration Measurement*—Place the cup on the penetrometer table, making certain that it cannot teeter. Set the mechanism to hold the cone in the zero position of the indicator dial, and adjust the apparatus carefully so that the tip of the

cone just touches the surface at the center of the test sample. Watching the shadow of the cone tip is an aid to accurate setting. Release the cone shaft rapidly, and allow it to drop for 5.0 ± 0.1 s. The release mechanism should not drag on the shaft. Gently depress the indicator shaft until stopped by the cone shaft and read the penetration to the nearest full unit (0.1 mm) from the indicator.

NOTE 4—If the indicator shaft is depressed with force, the penetration measurement may vary considerably.

7.5 Additional Testing—Make a total of three tests on the specimen, positioning the cone in the center of the specimen each time. Between each measurement, replace the grease adhering to the cone with some of the portion removed and saved earlier (7.2). The cup will need to be jarred to remove any trapped air and the surface will need to be leveled, as described in 7.2. The cone also needs to be cleaned between measurements, as described in 7.3. Report the average value of the three measurements, to the nearest 0.1 mm, as the ¼-scale or ½-scale unworked penetration of the sample.

8. Procedure for Worked Penetration

8.1 Sample—Sufficient sample to overfill the cup of the appropriate grease worker is required.

8.2 Working—Transfer sufficient specimen to the cup of the clean grease worker to fill it heaping full, mounded up about 7 mm (0.25 in.) at the center, avoiding the inclusion of air by packing with the spatula. Jar the cup from time to time as it is being packed to remove any air inadvertently entrapped. Assemble the worker and, with the vent cock open, depress the plunger to the bottom. Close the vent cock and place the assembled worker in the temperature bath maintained at $25 \pm 0.5^\circ\text{C}$ ($77 \pm 1^\circ\text{F}$) until the temperature of the worker and contents are at $25 \pm 0.5^\circ\text{C}$ ($77 \pm 1^\circ\text{F}$). Then remove the worker from the bath and wipe off any water adhering to its surfaces. Subject the grease to 60 full double strokes of the plunger, completed in $1 \text{ min} \pm 5 \text{ s}$, and return the plunger to its top position. Open the vent cock, remove the top and plunger, and return to the cup as much of the grease clinging to the plunger as can readily be removed. As the worked penetration of a lubricating grease can change significantly on standing, proceed in accordance with 8.3 and 8.4, immediately.

NOTE 5—If a water bath is used and if it is desired to immerse the portion of the worker above its closure, take care that the lid is watertight in order to prevent the entrance of water to the worker.

8.3 Preparing Sample for Measurement—Prepare the worked specimen in the cup for testing so that a uniform and reproducible structure of the grease will be obtained. Jar the cup sharply on the bench or floor and pack the grease down with a spatula to fill the holes left by the plunger and to remove any air pockets. Scrape off the excess grease extending above the rim of the cup, creating a flat surface, by moving the blade of the spatula, held inclined toward the direction of motion at an angle of approximately 45° , across the rim of the cup retaining the portion removed.

NOTE 6—The jarring should be as vigorous as required to remove the entrapped air without splashing the specimen from the cup. In performing these operations, a minimum of manipulation should be used, as any

TABLE 1 Repeatability (Unconverted Units)

	¼-Scale Units	½-Scale Units
Unworked	2	4
Worked	3	4

agitation of the grease can have the effect of increasing the working beyond the specified 60 strokes.

NOTE 7—Retain the grease removed from the cup in scraping for subsequent tests. Keep the outside of the rim of the cup clean so that the grease forced by the penetrometer cone to overflow the cup can be returned to the cup prior to preparing the specimen for the next test.

8.4 Penetration Measurement—Determine the penetration of the specimen three times, as described in 7.3, 7.4, and 7.5. Report the average of the three tests, to the nearest 0.1 mm, as the ¼-scale or ½-scale worked penetration of the sample.

9. Calculation

9.1 The penetration values obtained from the ¼-scale and ½-scale cone equipment in 7.5 shall be converted to full-scale penetrations (Test Methods D217) by the following equations:

9.1.1 ¼ Scale:

$$P = 3.75p + 24 \quad (1)$$

where:

P = cone penetration by Test Methods D217, and
 p = cone penetration by ¼-scale equipment.

9.1.2 ½ Scale:

$$P = 2r + 5 \quad (2)$$

where:

P = cone penetration by Test Methods D217, and
 r = cone penetration by ½-scale equipment.

NOTE 8—Full-scale penetration values derived from the ¼-scale or the ½-scale may differ from those obtained using Test Methods D217. Parties interested in using full-scale penetration values converted from the ¼-scale or the ½-scale results may use modified conversion equations when mutually agreeable.

10. Report

10.1 Do not report the actual penetration values from the ¼-scale or the ½-scale cone equipment (unless specified by the user). Report only the calculated values from the conversion equations in 9.1.1 and 9.1.2.

11. Precision and Bias ⁴

11.1 *Precision*—The precision of these test methods has been obtained in accordance with the requirements of Committee D02, RR:D02-1007). The precision of these test methods as determined by statistical examination of interlaboratory results is as follows:

11.1.1 *Repeatability*—The difference between two test results obtained by the same operator with the same apparatus under constant operating conditions on identical test material would, in the long run, in the normal and correct operation of these test methods, exceed the values in Table 1 in only one case in twenty.

⁴ Supporting data have been filed at ASTM International Headquarters and may be obtained by requesting Research Report RR:D02-1689.

TABLE 2 Reproducibility (Unconverted Units)

	¼-Scale Units	½-Scale Units
Unworked	21	16
Worked	18	18

11.1.2 *Reproducibility*—The difference between two single and independent test results obtained by different operators working in different laboratories on identical test material would, in the long run, in the normal and correct operation of the test methods, exceed the values in **Table 2** in only one case

in twenty.

11.2 *Bias*—Because there is no accepted reference material suitable for determining bias for the procedure in these test methods for measuring cone penetration of lubricating grease by one-quarter and one-half scale equipment, bias cannot be determined.

12. Keywords

12.1 ¼-scale; ½-scale; consistency; grease; lubricating grease; penetration; penetrometer; unworked penetration; worked penetration

ANNEX

(Mandatory Information)

A1. APPARATUS

A1.1 *One-Quarter Scale Cone and Shaft*—The cone shall be made of plastic or other lightweight material with hardened steel tip of 45 to 50 Hardness, Rockwell C Scale and shall be constructed to conform to the dimensions and tolerances shown in **Fig. A1.1**. The shaft may be made of magnesium. The total mass of the cone and its movable attachments shall be 9.38 ± 0.025 g. The total mass of the cone and its movable attachments may be adjusted by adding small shot to the cavity of the shaft.

A1.2 *One-Quarter Scale Grease Worker* shall conform to the dimensions given in **Fig. A1.2**. Other methods of fastening the cover and securing the worker may be used. The worker may be constructed for either manual or mechanical operation. Design shall be such that a rate of 60 ± 10 strokes per minute, with a minimum length of 14 mm ($\frac{9}{16}$ in.), can be maintained.

A1.3 *One-Half Scale Cone and Shaft*—The cone shall be made of steel, stainless steel, or brass with the tip of 45 to 50 Hardness, Rockwell C Scale and shall be constructed to conform to the dimensions and tolerances shown in **Fig. A1.3**. The shaft may be made of stainless steel. The total mass of the cone and its movable attachments shall be 37.5 ± 0.050 g. The mass of the cone shall be 22.5 ± 0.025 g. The mass of the movable attachments shall be 15 ± 0.025 g.

A1.4 *One-Half Scale Grease Worker* shall conform to the dimensions given in **Fig. A1.4**. Other methods of fastening the cover and securing the worker may be used. The worker may be constructed for either manual or mechanical operation. Design shall be such that a rate of 60 ± 10 strokes per minute, with a minimum length of 35 mm ($1\frac{3}{8}$ in.), can be maintained.

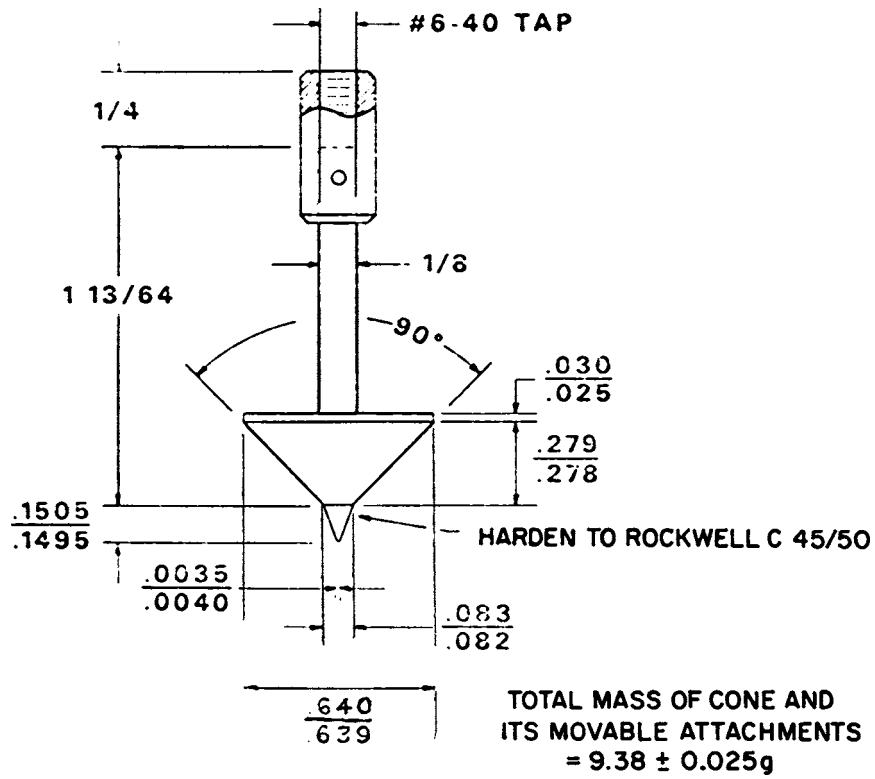

NOTE—All dimensions are in inches. Tolerance of fractional dimensions is $\pm 1/64$ in. (± 0.4 mm).

Approximate Metric Equivalents

Inches	Millimetres
$1/8$	3.2
$1/4$	6.4
$1\ 13/64$	30.6
0.0035	0.09
0.0040	0.10
0.025	0.64
0.030	0.76
0.082	2.08
0.083	2.11
0.1495	3.80
0.1505	3.82
0.278	7.06
0.279	7.09
0.639	16.23
0.640	16.26

FIG. A1.1 One-Quarter Scale Cone

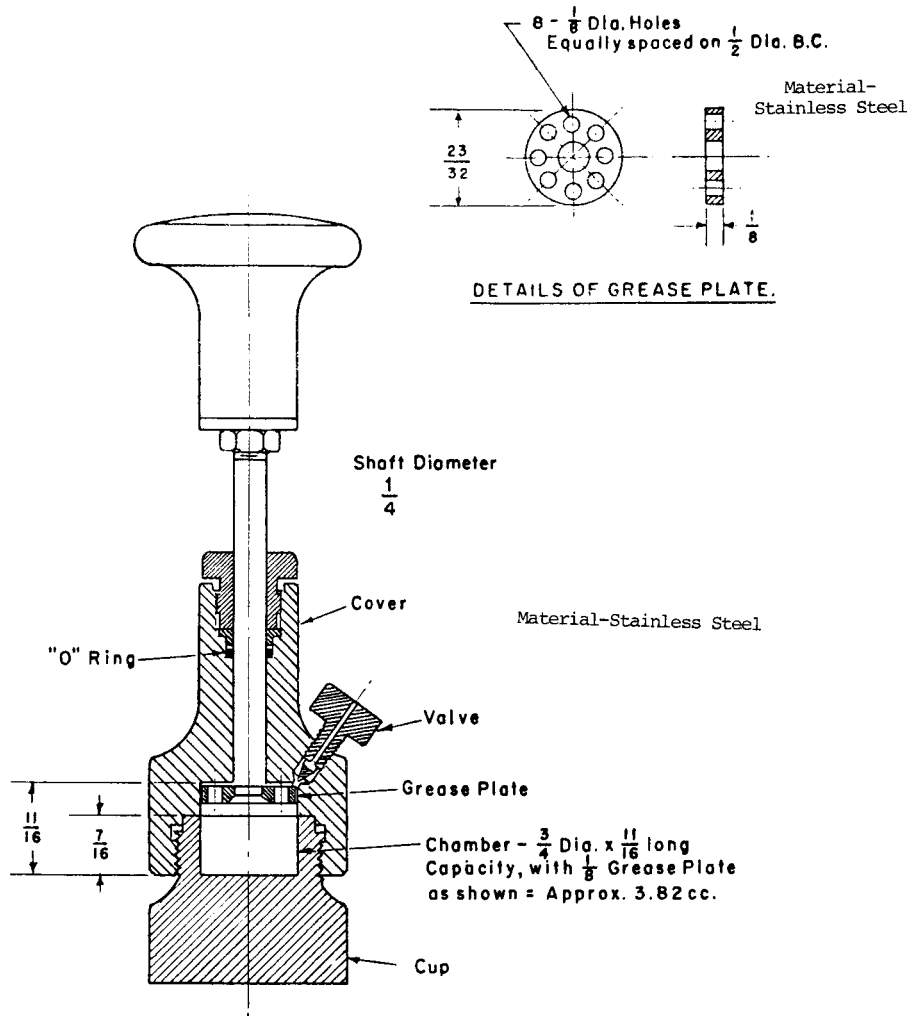

NOTE—All dimensions are in inches. Tolerance of fractional dimensions is $\pm \frac{1}{64}$ in. (± 0.4 mm).

Approximate Metric Equivalents	
Inches	Millimetres
$\frac{1}{8}$	3.2
$\frac{1}{4}$	6.4
$\frac{7}{16}$	11.1
$\frac{7}{16}$	12.7
$\frac{11}{16}$	17.5
$\frac{23}{32}$	18.2
$\frac{3}{4}$	19.0

FIG. A1.2 One-Quarter Scale Grease Worker

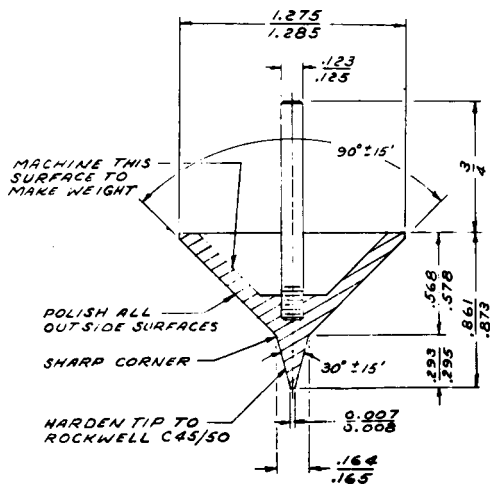

Mass of cone = 22.5 ± 0.025 g
 Mass of movable attachments = 15 ± 0.025 g
 Total mass of cone and its movable attachments = 37.5 ± 0.050 g

NOTE—All dimensions are in inches.

Approximate Metric Equivalents

Inches	Millimetres
$\frac{3}{4}$	19
0.007	0.18
0.008	0.20
0.123	3.12
0.125	3.18
0.164	4.17
0.165	4.19
0.293	7.44
0.295	7.49
0.568	14.43
0.578	14.68
0.861	21.87
0.873	22.17
1.275	32.38
1.285	32.64

FIG. A1.3 One-Half Scale Cone

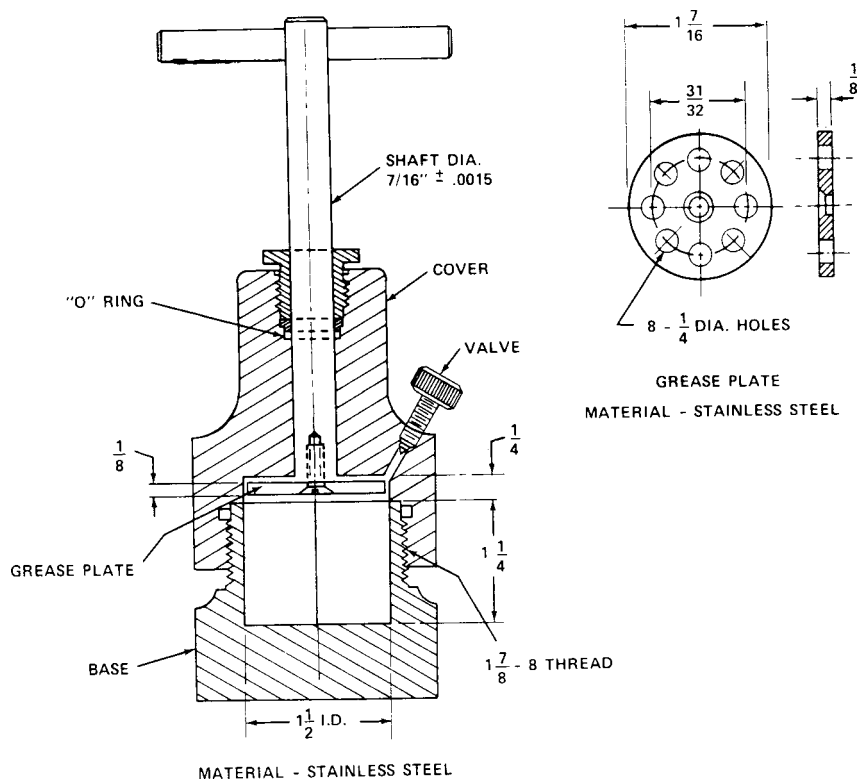

NOTE—All dimensions are in inches unless otherwise specified. Tolerance of fractional dimensions is $\pm 1/64$ in. (± 0.4 mm).

Approximate Metric Equivalents

Inches	Millimetres
1/8	3.2
1/4	6.4
7/16 ± 0.0015	11.1 ± 0.04
31/32	24.6
1 1/4	31.8
1 7/16	36.5
1 1/2	38.1

FIG. A1.4 One-Half Scale Grease Worker

SUMMARY OF CHANGES

Subcommittee D02.G0 has identified the location of selected changes to this standard since the last issue (D1403-02(2007)) that may impact the use of this standard.

- (1) Revised 6.6 to describe options for bringing the grease sample and test equipment to test temperature.
- (2) Deleted original Note 2, 7.4.1, and 8.5 to remove redundant or obsolete information.
- (3) Revised 7.1, 7.2, and 7.5 to standardize sample size for each test method and sample preparation and retention techniques with the revised test protocol.

- (4) Added Note 2 and Note 3 to include additional information regarding sample preparation and retention techniques.
- (5) Revised 8.2 and 8.4 to be consistent with renumbering of earlier sections and to describe the new technique for making repeat determinations on a single specimen.
- (6) Revised 11.1 to include reference to new Research Report.
- (7) Revised Table 1 to include updated precision data.

ASTM International takes no position respecting the validity of any patent rights asserted in connection with any item mentioned in this standard. Users of this standard are expressly advised that determination of the validity of any such patent rights, and the risk of infringement of such rights, are entirely their own responsibility.

This standard is subject to revision at any time by the responsible technical committee and must be reviewed every five years and if not revised, either reapproved or withdrawn. Your comments are invited either for revision of this standard or for additional standards and should be addressed to ASTM International Headquarters. Your comments will receive careful consideration at a meeting of the responsible technical committee, which you may attend. If you feel that your comments have not received a fair hearing you should make your views known to the ASTM Committee on Standards, at the address shown below.

This standard is copyrighted by ASTM International, 100 Barr Harbor Drive, PO Box C700, West Conshohocken, PA 19428-2959, United States. Individual reprints (single or multiple copies) of this standard may be obtained by contacting ASTM at the above address or at 610-832-9585 (phone), 610-832-9555 (fax), or service@astm.org (e-mail); or through the ASTM website (www.astm.org). Permission rights to photocopy the standard may also be secured from the ASTM website (www.astm.org/COPYRIGHT/).