



Standard Test Method for Dropping Point of Lubricating Grease Over Wide Temperature Range¹

This standard is issued under the fixed designation D2265; the number immediately following the designation indicates the year of original adoption or, in the case of revision, the year of last revision. A number in parentheses indicates the year of last reapproval. A superscript epsilon (ϵ) indicates an editorial change since the last revision or reapproval.

This standard has been approved for use by agencies of the Department of Defense.

1. Scope

1.1 This test method covers the determination of the dropping point of lubricating grease.

1.2 *This standard does not purport to address all of the safety concerns, if any, associated with its use. It is the responsibility of the user of this standard to establish appropriate safety and health practices and determine the applicability of regulatory limitations prior to use.*

2. Referenced Documents

2.1 *ASTM Standards:*²

[D217 Test Methods for Cone Penetration of Lubricating Grease](#)

[D566 Test Method for Dropping Point of Lubricating Grease](#)

[D3244 Practice for Utilization of Test Data to Determine Conformance with Specifications](#)

[E1 Specification for ASTM Liquid-in-Glass Thermometers](#)

3. Terminology

3.1 *Definitions:*

3.1.1 *dropping point, n*—a numerical value assigned to a grease composition representing the corrected temperature at which the first drop of material falls from the test cup and reaches the bottom of the test tube.

3.1.1.1 *Discussion*—In the normal and proper operation of this test method, the observed dropping point is corrected by adding to it a value representing one third of the difference between the oven block temperature and the observed dropping

point temperature. This corrected value is recorded as the dropping point of the grease.

3.1.2 *lubricating grease, n*—a semi-fluid to solid product of a thickener in a liquid lubricant.

3.1.2.1 *Discussion*—The dispersion of the thickener forms a two-phase system and immobilizes the liquid lubricant by surface tension and other physical forces. Other ingredients are commonly included to impart special properties. **D217**

3.1.3 *observed dropping point, n*—the value noted on the thermometer monitoring the internal temperature of the grease test cup when the first drop of material falls from the test cup and reaches the bottom of the test tube.

3.1.4 *thickener, n—in lubricating grease*, a substance composed of finely-divided particles dispersed in a liquid to form the product's structure.

3.1.4.1 *Discussion*—Thickeners can be fibers (such as various metallic soaps) or plates or spheres (such as certain non-soap thickeners), which are insoluble or, at most, only very slightly soluble in the liquid lubricant. The general requirements are that the solid particles be extremely small, uniformly dispersed, and capable of forming a relatively stable, gel-like structure with the liquid lubricant. **D217**

4. Summary of Test Method

4.1 A grease sample in a grease test cup is supported in a test tube placed in an aluminum block oven at a preset constant temperature. A sample thermometer is placed in the tube and so positioned that it measures the temperature in the sample cup without coming in contact with the grease.

4.2 As the temperature increases, at some point a drop of material will fall from the cup to the bottom of the test tube. The reading on the sample thermometer is recorded to the nearest degree as the observed dropping point. At the same time, the temperature of the aluminum block oven is also recorded to the nearest degree.

4.3 One third the difference between the two values is the correction factor which is added to the observed value and recorded as the dropping point of the grease.

¹ This test method is under the jurisdiction of ASTM Committee D02 on Petroleum Products and Lubricants and is the direct responsibility of Subcommittee D02.G0 on Lubricating Grease.

Current edition approved May 1, 2006. Published May 2006. Originally approved in 1964. Last previous edition approved in 2000 as D2265-00. DOI: 10.1520/D2265-06.

² For referenced ASTM standards, visit the ASTM website, www.astm.org, or contact ASTM Customer Service at service@astm.org. For *Annual Book of ASTM Standards* volume information, refer to the standard's Document Summary page on the ASTM website.

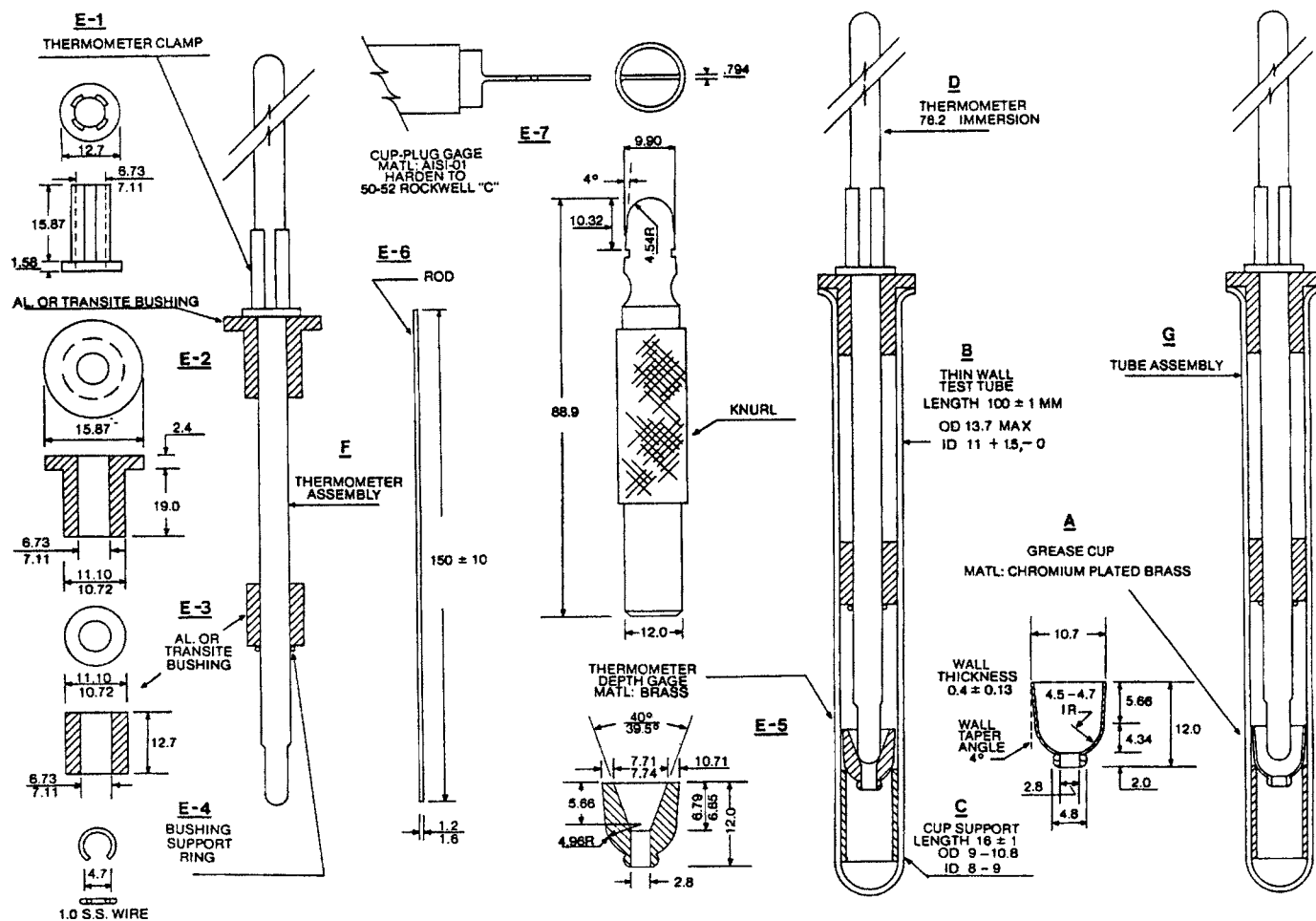

(a) Dimensions in millimetres.

FIG. 1 Apparatus for Dropping Point Test of Lubricating Grease

5. Significance and Use

5.1 The dropping point is useful to assist in identifying the grease as to type and for establishing and maintaining bench marks for quality control. The results are to be considered to have only limited significance with respect to service performance because dropping point is a static test.

5.2 Cooperative testing³ indicates that, in general, dropping points by Test Method D2265 and Test Method D566 are in agreement up to 260°C. In cases where results differ, there is no known significance. However, agreement between the manufacturer and purchaser as to test method used is advisable.

6. Apparatus

6.1 *Dropping Point Assembly* (Fig. 1) consisting of the following:

6.1.1 *Grease Cup*, chromium-plated brass cup conforming to the dimensions shown in A, Fig. 1.

6.1.2 *Test Tube*, thin walled, soft glass test tube with rim, having dimensions shown in B, Fig. 1.

6.1.3 *Cup Support*, glass tubing as shown in C, Fig. 1.

6.1.4 *Thermometer*, thermometer 3C as prescribed in Specification E1 and shown in D, Fig. 1.

6.1.5 *Accessories*, thermometer clamp as shown in E-1, bushings as shown in E-2 and E-3, bushing support ring as shown in E-4, thermometer depth gage as shown in E-5, a metal rod as shown in E-6, and cup gage as shown in E-7, all of Fig. 1.

6.2 *Aluminum Block Oven*, aluminum block oven of the design and dimensions shown in Fig. 2. The block shall be equipped with an integral cartridge-type heater. Control of the current to the heater shall be used to obtain and maintain the desired oven temperature.

6.2.1 *Aluminum Block Oven Thermometer*, conforming to thermometer 11C in accordance with Specification E1.

7. Sampling

7.1 The sample presented for analysis should be large enough to make possible the selection of a representative portion for testing. Examine for any indication of non-homogeneity such as oil separation, phase changes, or gross contamination. If any abnormal conditions are found, obtain a new sample.

³ Supporting data have been filed at ASTM International Headquarters and may be obtained by requesting Research Report D02-1164.

DROPPING POINT APPARATUS

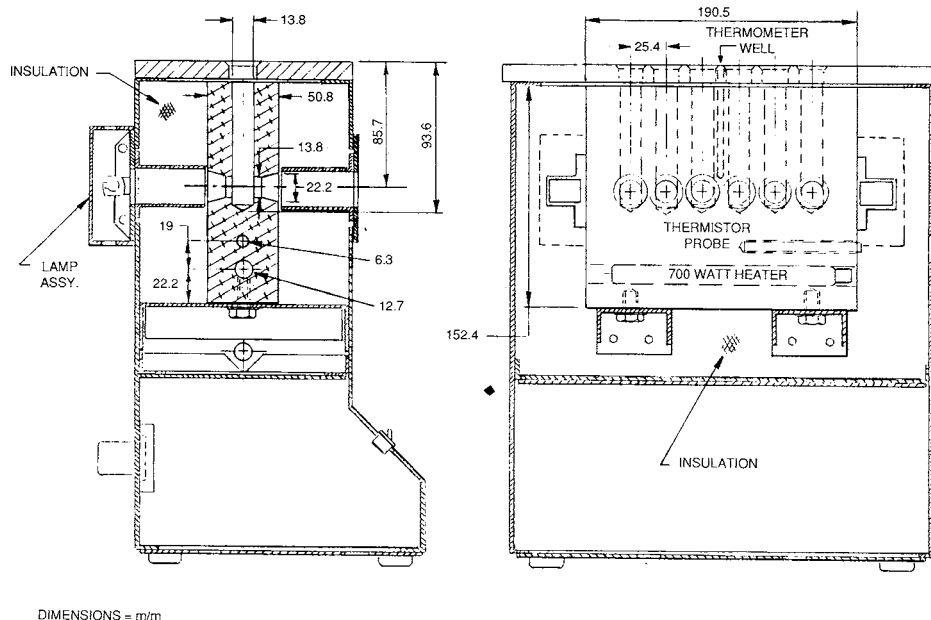

FIG. 2 Aluminum Block Oven

8. Preparation of Apparatus

8.1 Thoroughly clean the cup, cup support, and test tube with mineral spirits. (**Warning**—Flammable. Vapor harmful.)

8.2 Use only cups that are clean and free of any residue. When the interior plating of the cup shows indications of wear, discard.

8.3 When new cups are to be used, check their dimensions by using the cup plug gage (E-7 of Fig. 1). To check the bottom opening of the cup a 2.78 mm rod should fit easily while a 2.82 mm rod should not.⁴ If the hole is undersize, ream to the correct size. If too large, discard. Cups of the proper dimensions need not be rechecked before each test run.

8.4 Test tubes shall be clean and free of residues and conform to the dimensions shown in B, Fig. 1. Inspect for chips or cracks and replace when necessary.

8.5 Sample thermometer bulb shall be clean and free of residues. Inspect bushings for cleanliness and be certain the thermometer clamp, E-1, Fig. 1, is sufficiently tight to hold the thermometer in position.

8.6 The glass sleeve used to support the cup shall be free of any cracks or chips, residue or stain, and conform to the dimensions shown in C, Fig. 1. Replace when necessary.

9. Procedure

9.1 Insert empty test tubes in every test tube well and a thermometer having a range from - 5 to 400°C in the thermometer well of the oven.

9.2 Turn on the oven and select the lowest aluminum block oven temperature setting from the four listed below that will result in an observed dropping point at or below the corre-

sponding maximum observed dropping point shown for that oven temperature setting.

Oven Temperature, °C	Maximum Observed Dropping Point, °C
121 ± 3	116
232 ± 3	221
288 ± 3	277
316 ± 3	304

9.3 Select and use test tubes and accessories E-1, E-2, and E-3 to minimize wobble of the thermometer. All components must be at room temperature prior to the test. Place the components E-1 through E-4 on the thermometer in the order shown by the thermometer assembly (F) Fig. 1. Adjust the bushing E-3 and the bushing support ring E-4 so that E-4 is about 25 mm from the tip of the thermometer. Place the cup support C in tube B. Insert the thermometer depth gage E-5 and the thermometer assembly in the tube. Position the thermometer so that the tip bottoms in the gage. Adjust the bushing E-2 and the thermometer clamp E-1 so that the bushing shoulders on the top edge of the tube.

9.4 Select a clean cup, and fill it with grease either by pushing the cup into the sample presented or by using a small spatula. Overfill the cup, and use the spatula to force some of the grease out of the bottom hole of the cup to help remove any trapped air. Add more sample, and strike off the excess grease level with the top of the cup. Gently press the cup, held in a vertical position with the smaller opening at the bottom, down over the metal rod E-6, Fig. 1, until the latter protrudes about 25 mm. Press the rod against the cup in such a manner that the rod makes contact at both the upper and lower peripheries of the cup. Maintain this contact, rotating the cup on the rod along the index finger to give it a spiral-like motion down the rod to

⁴ These are commonly available as a 7/64-in. drill and a No. 34 drill, respectively.

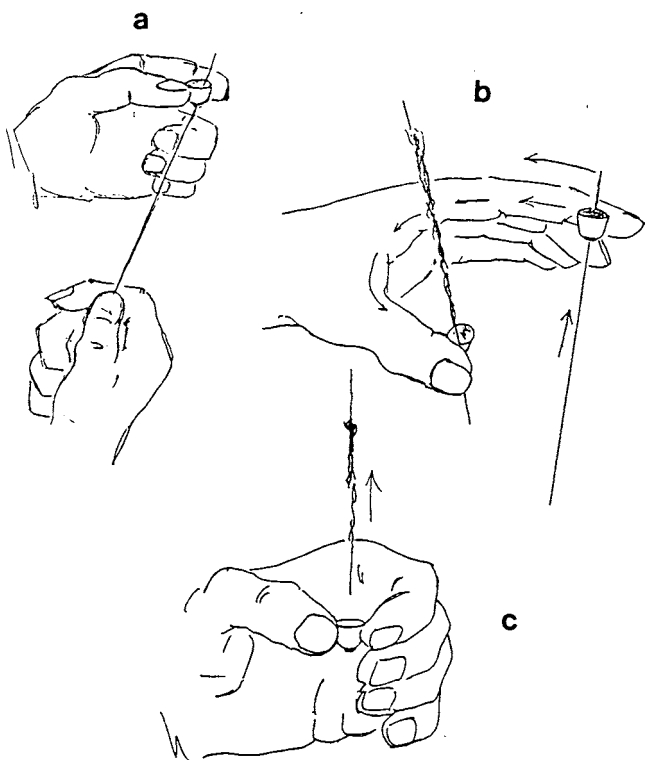

FIG. 3 Technique for Filling Grease Cup

remove a conical section of the grease which adheres along the rod. As the cup approaches the end of the rod, carefully slip the rod out of the cup, without marring the inside surface of the grease, so that a smooth film of reproducible thickness remains inside the cup. If the surface has been touched by the rod or any air bubbles are noted, repack the cup. See Fig. 3.

9.5 Remove the thermometer assembly and depth gage from the tube. Place the grease cup on the cup support in the test tube and carefully reinsert the thermometer assembly. Make no further adjustment as the thermometer bulb is now positioned to provide adequate clearance between the tip of the bulb and grease sample in the cup.

9.6 After making certain that the oven temperature has stabilized, remove an empty tube from the oven and gently insert the tube assembly, G, (Fig. 1) in its place. Exercise care to ensure that the cup remains upright in the cup support. If the cup is tilted, the thermometer bulb can come in contact with the film of grease and result in an erroneous value.

9.7 When the first drop of material falls free of the cup orifice and reaches the bottom of the test tube, record both the temperature of the cup and of the oven to the nearest degree. Certain greases, for example, some simple soap compositions, or those containing some types of polymers can form a drop with a tailing thread which can hold until the drop reaches the bottom of the test tube. The temperature in the cup when the drop reaches the bottom of the test tube is recorded as the observed dropping point.

NOTE 1—The aluminum block oven can accommodate up to six

samples of the same or different greases so that multiple determinations can be made simultaneously.

10. Calculation

10.1 Calculate the dropping point as follows:

$$DP = ODP + [(BT - ODP)/3]$$

where:

- DP = dropping point,
- ODP = thermometer reading when first drop reaches the bottom of the test tube, and
- BT = block temperature when the drop falls.

11. Report

11.1 Report the following information:

- 11.1.1 Sample identification,
- 11.1.2 The corrected dropping point, and
- 11.1.3 The aluminum block oven temperature immediately after the drop was observed.
- 11.1.4 Follow local laboratory protocol for additional reportable requirements.

12. Precision and Bias

12.1 The precision of this test method is not known to have been obtained in accordance with currently accepted guidelines in Committee D02 Research Report D02-1007.

12.1.1 *Repeatability*—The difference between two test results obtained by the same operator with the same apparatus under constant operating conditions on identical test material would, in the long run, in the normal and correct operation of the test method, exceed the following values in only one case in twenty:

Greases Dropping °C	°C (Note 2 and Note 3)
Up to 116	6
116 up to 221	8
221 up to 277	6
277 up to 316	7

12.1.2 *Reproducibility*—The difference between two single and independent results obtained by different operators working in different laboratories on identical test material would, in the long run, in the normal and correct operation of the test method, exceed the following values in only one case in twenty:

Greases Dropping °C	°C (Note 2 and Note 3)
Up to 116	9
116 up to 221	12
221 up to 277	16
277 up to 316	12

12.2 *Bias*—There is no bias for this test method because the value of the dropping point can be defined only in terms of the test method.

NOTE 2—When results do not agree within the limits shown, proceed as described in Practice D3244.

NOTE 3—Values for greases dropping below 221°C based on the use of the older heavy wall temperature resistant tubes. Values for greases dropping above 221°C are based on the use of the thin wall test tube (6.1.2).

NOTE 4—The dropping points of some greases, particularly those containing simple soaps, are known to decrease upon aging, the change being much greater than the deviation permitted in results obtained by different laboratories. Therefore, comparative tests between laboratories should be made within a period of six days.

NOTE 5—The cooperative data given in *NLGI Spokesman*,⁵ indicate that precision varied with dropping point range.

13. Keywords

13.1 dropping point; greases; lubricating grease

⁵ *NLGI Spokesman*, Vol 31, 1967, p. 76.

APPENDIX

(Nonmandatory Information)

X1. PRECISION VALUES

X1.1 The precision values shown in 12.1.1 and 12.1.2 were developed from the round robin of 1991 using seven greases: a lithium complex synthetic base, two lithium complex oil bases, two lithium 12-hydroxy stearates, an aluminum complex, and a polyurea.

X1.2 The original values for the deleted 343°C block temperature are noted below for informational purposes.

Repeatability 6°C

Reproducibility 24°C

ASTM International takes no position respecting the validity of any patent rights asserted in connection with any item mentioned in this standard. Users of this standard are expressly advised that determination of the validity of any such patent rights, and the risk of infringement of such rights, are entirely their own responsibility.

This standard is subject to revision at any time by the responsible technical committee and must be reviewed every five years and if not revised, either reapproved or withdrawn. Your comments are invited either for revision of this standard or for additional standards and should be addressed to ASTM International Headquarters. Your comments will receive careful consideration at a meeting of the responsible technical committee, which you may attend. If you feel that your comments have not received a fair hearing you should make your views known to the ASTM Committee on Standards, at the address shown below.

This standard is copyrighted by ASTM International, 100 Barr Harbor Drive, PO Box C700, West Conshohocken, PA 19428-2959, United States. Individual reprints (single or multiple copies) of this standard may be obtained by contacting ASTM at the above address or at 610-832-9585 (phone), 610-832-9555 (fax), or service@astm.org (e-mail); or through the ASTM website (www.astm.org). Permission rights to photocopy the standard may also be secured from the ASTM website (www.astm.org/COPYRIGHT/).