



# Standard Test Method for Copper Strip Corrosion by Liquefied Petroleum (LP) Gases<sup>1</sup>

This standard is issued under the fixed designation D1838; the number immediately following the designation indicates the year of original adoption or, in the case of revision, the year of last revision. A number in parentheses indicates the year of last reapproval. A superscript epsilon ( $\epsilon$ ) indicates an editorial change since the last revision or reapproval.

## 1. Scope\*

1.1 This test method covers the detection of the presence of components in liquefied petroleum gases which may be corrosive to copper.

NOTE 1—For an equivalent copper strip test applicable to less volatile petroleum products, see Test Method D130.

1.2 The values stated in SI units are to be regarded as standard. The values given in parentheses are for information only.

1.3 *This standard does not purport to address all of the safety concerns, if any, associated with its use. It is the responsibility of the user of this standard to establish appropriate safety and health practices and determine the applicability of regulatory limitations prior to use.* For specific warning statements, see 6.1, 9.3.1, and Annex A1.

## 2. Referenced Documents

2.1 *ASTM Standards:*<sup>2</sup>

D130 Test Method for Corrosiveness to Copper from Petroleum Products by Copper Strip Test

E1 Specification for ASTM Liquid-in-Glass Thermometers

D1265 Practice for Sampling Liquefied Petroleum (LP) Gases, Manual Method

D3700 Practice for Obtaining LPG Samples Using a Floating Piston Cylinder

2.2 *ASTM Adjuncts:*

ADJD0130, ASTM Copper Strip Corrosion Standard for Petroleum<sup>3</sup>

## 3. Summary of Test Method

3.1 A polished copper strip is immersed in approximately 100 mL of the sample and exposed at a temperature of 37.8°C

<sup>1</sup> This test method is under the jurisdiction of ASTM Committee D02 on Petroleum Products and Lubricants and is the direct responsibility of Subcommittee D02.H0 on Liquefied Petroleum Gas.

Current edition approved Nov. 1, 2007. Published November 2007. Originally approved in 1961. Last previous edition approved in 2006 as D1838-06. DOI: 10.1520/D1838-07.

<sup>2</sup> For referenced ASTM standards, visit the ASTM website, www.astm.org, or contact ASTM Customer Service at service@astm.org. For *Annual Book of ASTM Standards* volume information, refer to the standard's Document Summary page on the ASTM website.

<sup>3</sup> Available from ASTM International Headquarters. Order Adjunct No. ADJD0130.

(100°F) for 1 h in a cylinder of suitable working pressure. At the end of this period, the copper strip is removed and rated as one of the four classifications of the ASTM Copper Corrosion Standards.

## 4. Significance and Use

4.1 Copper corrosion limits provide assurance that difficulties will not be experienced in deterioration of the copper and copper-alloy fittings and connections that are commonly used in many types of utilization, storage, and transportation equipment.

## 5. Apparatus

5.1 *Corrosion Test Cylinder*, constructed of stainless steel with an O-ring removable top closure according to the dimensions given in Fig. 1. Provide a flexible inert hose, such as one composed of aluminum or stainless steel, which permits inverting the test cylinder as required in the procedure (see Note 2). The whole assembly, including the corrosion test cylinder, shall be constructed to withstand a minimum hydrostatic test pressure of 6900 kPa (1000 psig). No leak shall be discernible when tested at 3450 kPa (500 psig) with gas.

NOTE 2—Swivel connections with an adapter to fit a 6.4 mm (1/4 in.) pipe may be used.

5.1.1 The assembly shall be tested for compliance with the minimum pressure rating of 6900 kPa (1000 psig) by hydrostatic testing, or alternative testing protocol acceptable to the local authority having jurisdiction, prior to first use. Additional testing can be required by the local authority having jurisdiction.

5.1.2 The assembly shall be verified for gas tightness by leak testing at 3450 kPa (500 psig) with inert gas prior to first use, whenever pressure-containing components of the assembly are replaced, or otherwise on an annual basis.

5.1.3 Note the presence and length (about 60 mm) of the outage tube shown in Fig. 1, to provide adequate ullage for safety. A safety pressure relief device may also be incorporated into the design of the corrosion test cylinder, if desired. If a pressure relief device is incorporated, ensure that the materials of its construction will not affect the test results.

\*A Summary of Changes section appears at the end of this standard.

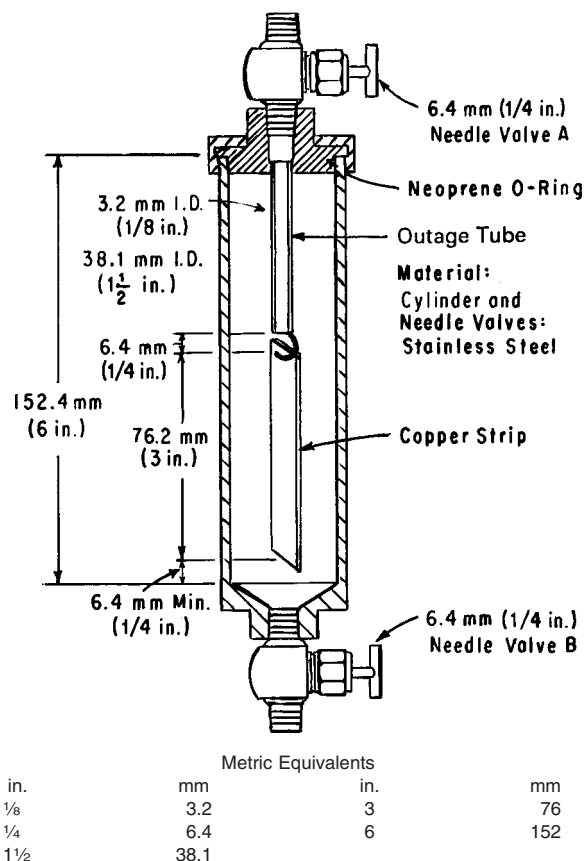

FIG. 1 Copper Strip Corrosion Test Cylinder

5.2 *Water Bath*, capable of being maintained at 37.8 ± 0.5°C (100 ± 1°F). Incorporate suitable supports to hold the test cylinder in an upright position. Make the bath deep enough so that the entire cylinder and valves will be covered during the test.

5.3 *Temperature Sensing Device (TSD)*—Capable of monitoring the desired test temperature in the bath to within an accuracy of ±0.5°C (1°F) or better. The ASTM 12C (12F) total immersion thermometer has been found suitable to use in the test (see Specification E1). If used, no more than 25 mm (1 in.) of the mercury should extend above the surface of the bath at the test temperature.

5.4 *Strip Polishing Vise*, to hold the copper strip firmly without marring the edges. For convenient vises see Test Method D130.

6. Materials

6.1 *Wash Solvent*—Use acetone or knock test grade 2.2.4 trimethylpentane. (Warning—Extremely flammable. See Annex A1.)

6.2 *Copper Strip*, approximately 12.5 mm (1/2 in.) wide, 1.5 to 3.0 mm (1/16 to 1/8 in.) thick, cut approximately 75 mm (3 in.) long from smooth-surfaced, hard-temper, cold-finished copper of 99.9 + % purity; electrical bus bar stock is generally suitable. Drill a 3.2 mm (1/8 in.) hole approximately 3.2 mm (1/8 in.) from one end in the center of the strip. The strips may be used repeatedly but should be discarded if surfaces become deformed.

6.3 *Surface Preparation/Polishing Materials*—00 grade or finer steel wool; silicon carbide grit paper or cloth of varying degrees of fineness including 65-µm (240-grit) grade; also a supply of 105-µm (150-mesh) size silicon carbide grain or powder and absorbent cotton. A commercial grade is suitable, but pharmaceutical grade cotton wool is most commonly available and is acceptable.

6.4 *Copper Corrosion Standard Plaques* are available.<sup>3</sup> Their care and inspection for stability are described in detail in Test Method D130.

7. Preparation of Strips

7.1 *Surface Preparation*—Remove all surface blemishes from all six sides of the strip obtained from a previous analysis. One way to accomplish this is to use 00 grade or finer steel wool or silicon carbide paper or cloth of such degrees of fineness as are needed to accomplish the desired results efficiently. Finish with 65-µm (240-grit) silicon carbide paper or cloth, removing all marks that may have been made by other grades of paper used previously. Ensure the prepared copper strip is protected from oxidation prior to final preparation, such as by immersing the strip in wash solvent from which it can be withdrawn immediately for finish preparation (polishing) or in which it can be stored for future use.

7.1.1 As a practical manual procedure for surface preparation, a sheet of silicon carbide paper may be placed on a flat surface and then moisten the paper with wash solvent before rubbing the strip against the silicon carbide paper or cloth with a circular motion. Protect the strip from contact with the fingers, such as by using ashless filter paper. Alternatively, the surface of the strip can be prepared by use of motor-driven machines using appropriate grades of dry paper or cloth.

7.2 *Final Preparation*—For strips prepared in 7.1 or new strips being used for the first time, remove a strip from its protected location, such as by removing it from the wash solvent. Polish first the ends and then the sides with the 105-µm (150-µm mesh) silicon carbide grains picked up with a pad of absorbent cotton moistened with wash solvent, making sure that the surface is protected from coming in contact with the fingers, such as by using ashless filter paper. Wipe vigorously with fresh pads of absorbent cotton and subsequently handle without touching the surface of the strip with the fingers. Padded forceps (to prevent the scratching of the surface) have been found suitable to use. Secure the copper strip in a vise or suitable holder and polish the main surfaces with silicon-carbide grains on absorbent cotton. Do not polish in a circular motion. Rub in the direction of the long axis of the strip, carrying the stroke beyond the end of the strip before reversing the direction. Clean all metal dust from the strip by rubbing vigorously with clean pads of absorbent cotton until a fresh pad remains unsoiled. When the strip is clean, with minimal delay, attach to the dip tube and lower into the prepared corrosion test cylinder (see Fig. 1).

7.2.1 It is important to polish the whole surface of the strip uniformly to obtain a uniformly stained strip. If the edges show wear (surface elliptical) they will likely show more corrosion than the center. The use of a vise will facilitate uniform polishing.

7.2.2 It is important to follow the order of preparation with the correctly sized silicon carbide material as described in 7.1 and 7.2. The final preparation is with 105- $\mu\text{m}$  silicon carbide grain. This is a larger grain size than the 65- $\mu\text{m}$  paper used in the surface preparation stage. The reason for this use of larger silicon carbide grains in the final preparation is to produce asperities (controlled roughness) on the surface of the copper, which acts as sites for the initiation of corrosion reactions.

## 8. Sampling

8.1 Obtain a sample from a point in the LPG system that will give a representative sample of the volume being tested, such as from a dynamic flowing stream or from a well mixed container, as appropriate. Preferably, collect the sample directly into the corrosion test cylinder (5.1) after it has been prepared for testing (9.1). Pay particular attention to safety and warning notes in Practices D1265 and D3700.

8.2 Alternatively, collect a sample in accordance with Practices D1265 and D3700.

8.2.1 If a sample is first collected in a sampling cylinder, ensure that the interior surfaces are inert and will not react with corrosive species. Sampling cylinders with protective (inert) internal coatings or surface treatments (such as fused glass) may be used.

NOTE 3—Some internal coatings are porous and can adsorb or release contaminants that can affect test results. Also, fresh steel surfaces can react with some corrosive sulfur species and potentially remove them, which could result in a “false pass” in the copper strip corrosion test.

8.3 The time between when the sample is collected and when the test is begun should be held to a minimum (preferably only a few minutes) (see Note 4).

8.4 In case of dispute, a sample shall be collected directly into a corrosion test cylinder.

## 9. Procedure

9.1 With Valve B (Fig. 1), open, place approximately 1 mL of distilled water into a clean test cylinder and swirl to moisten the walls; allow the remainder to drain from the cylinder, insert the freshly polished copper strip suspended from the hook on the dip tube making sure that the bottom of the strip is at least 6.4 mm ( $\frac{1}{4}$  in.) from the bottom of the cylinder when assembled. After assembly of the apparatus, close both Valve A (Fig. 1), on closure assembly with outage tube, and Valve B.

9.2 Holding the test cylinder upright so as not to wet the copper strip with water, attach the sample source to the test cylinder Valve A (Fig. 1) by means of a short length of flexible inert hose that has been purged with the sample. Admit some sample to the cylinder by opening the valve at the sample source and then Valve A.

9.3 Close Valve A without disconnecting the test cylinder from the sample source. Invert the test cylinder and open Valve B to purge the air from the test cylinder. Return the test cylinder to the upright position and drain any residual liquid through the open Valve B. Close Valve B with the test cylinder now in its upright position, open Valve A and fill the test cylinder with the sample. When the test cylinder is full, close Valve A, the valve at the sample source, and disconnect the tubing.

9.3.1 (**Warning**—Safe means for the disposal of vapors and liquids during this and subsequent procedures must be provided.)

9.4 As soon as the flexible inert hose is disconnected, and with the cylinder in its upright position, open Valve A slightly so that all liquid above the end of the outage tube will be removed from the test cylinder. When vapor first emerges from Valve A, close Valve A.

9.5 With minimal delay, and as soon as practical after filling and venting (described in 9.4) the test cylinder (see Note 4), immerse the test cylinder in the water bath maintained at  $37.8 \pm 0.5^\circ\text{C}$  ( $100 \pm 1^\circ\text{F}$ ). Allow the test cylinder to remain in the bath for  $1 \text{ h} \pm 5 \text{ min}$ .

NOTE 4—Any delay between preparing the test cylinder, collecting the sample, and immersing the test cylinder in the water bath gives the copper strip more time in the sample, and thus more time to potentially develop increased discoloration if corrosive species are present in the sample.

9.6 At the end of the test period remove the cylinder from the bath and, holding the cylinder in a vertical position, open the bottom valve to a suitable disposal unit (9.3.1) until all of the liquid and most of the vapor is discharged.

9.7 When only a slight pressure remains in the cylinder, disassemble immediately and compare at once the copper strip that has been exposed to the liquefied petroleum gases with the ASTM Copper Strip Corrosion Standards.

9.8 Handling only with stainless steel forceps, compare the exposed strip with the ASTM Copper Strip Corrosion Standards. Hold both the test strip and the standard in such a manner that light reflected from them at an angle of approximately  $45^\circ$  will be observed. In handling the test strip during the inspection and comparison, the danger of marking or staining can be avoided if it is inserted in a flat test tube which is then stoppered with absorbent cotton.

9.9 The added distilled water frequently causes isolated brown spots on the copper strip. The presence of these spots should be disregarded or the test should be repeated.

9.10 If the copper strip shows any appreciable discoloration, the interior of the cylinder should be polished with steel wool and washed with wash solvent soon after use so as to be clean for another test.

## 10. Report

10.1 Report the results in accordance with one of the classifications listed in Table 1. State the duration of the test and the test temperature.

## 11. Precision and Bias

11.1 In the case of ordinal classification data, no generally accepted method for determining precision or bias is currently available.

## 12. Keywords

12.1 copper corrosion; copper strip; liquefied petroleum gases

**TABLE 1 ASTM Copper Strip Classifications**

Classification	Designation	Description <sup>A</sup>
Freshly polished strip	...	<sup>B</sup>
1	Slight tarnish	Light orange, almost the same as a freshly polished strip Dark orange
2	Moderate tarnish	Claret red Lavender Multicolored with lavender blue and/or silver overlaid on claret red Silvery Brassy or gold
3	Dark tarnish	Magenta overcast on brassy strip Multicolored with red and green showing (peacock), but no gray
4	Corrosion	Transparent black, dark gray or brown with peacock green barely showing Graphite or lusterless black Glossy or jet black

<sup>A</sup> The ASTM Copper Corrosion Standard is made up to strips characteristic of these descriptions.

<sup>B</sup> The freshly polished strip is included in a series only as an indication of the appearance of a properly polished strip before a test run; it is not possible to duplicate this appearance after a test even with a completely noncorrosive sample.

## ANNEX

### (Mandatory Information)

#### A1. WARNING STATEMENT

##### A1.1 2.2.4 Trimethylpentane

A1.1.1 Keep away from heat, sparks, and open flame.

A1.1.2 Keep container closed.

A1.1.3 Use with adequate ventilation.

A1.1.4 Avoid buildup of vapors and eliminate all sources of ignition, especially non-explosion proof electrical apparatus and heaters.

A1.1.5 Avoid prolonged breathing of vapor or spray mist.

A1.1.6 Avoid prolonged or repeated skin contact.

#### SUMMARY OF CHANGES

Subcommittee D02.H0 has identified the location of selected changes to this standard since the last issue (D1838–06) that may impact the use of this standard. (Approved Nov. 1, 2007.)

(1) Revised 5.1.

(2) Added new paragraphs 5.1.1-5.1.3.

(3) Added new Section 8 and renumbered the rest of the sections accordingly.

(4) Added Practices D1265 and D3700 to the Referenced Documents and text.

(5) Moved 9.9 from Report section to the Procedure.

Subcommittee D02.H0 has identified the location of selected changes to this standard since the last issue (D1838–05) that may impact the use of this standard. (Approved July 1, 2006.)

(1) Updated 9.5.

(2) Added Note 4.

*ASTM International takes no position respecting the validity of any patent rights asserted in connection with any item mentioned in this standard. Users of this standard are expressly advised that determination of the validity of any such patent rights, and the risk of infringement of such rights, are entirely their own responsibility.*

*This standard is subject to revision at any time by the responsible technical committee and must be reviewed every five years and if not revised, either reapproved or withdrawn. Your comments are invited either for revision of this standard or for additional standards and should be addressed to ASTM International Headquarters. Your comments will receive careful consideration at a meeting of the responsible technical committee, which you may attend. If you feel that your comments have not received a fair hearing you should make your views known to the ASTM Committee on Standards, at the address shown below.*

*This standard is copyrighted by ASTM International, 100 Barr Harbor Drive, PO Box C700, West Conshohocken, PA 19428-2959, United States. Individual reprints (single or multiple copies) of this standard may be obtained by contacting ASTM at the above address or at 610-832-9585 (phone), 610-832-9555 (fax), or [service@astm.org](mailto:service@astm.org) (e-mail); or through the ASTM website ([www.astm.org](http://www.astm.org)).*