



# Standard Test Method for Solvent Extractables in Petroleum Waxes<sup>1</sup>

This standard is issued under the fixed designation D 3235; the number immediately following the designation indicates the year of original adoption or, in the case of revision, the year of last revision. A number in parentheses indicates the year of last approval. A superscript epsilon ( $\epsilon$ ) indicates an editorial change since the last revision or reapproval.

## 1. Scope\*

1.1 This test method covers the determination of solvent extractables in petroleum waxes.

1.2 The values stated in SI units are to be regarded as the standard. The values given in parentheses are for information only.

1.3 *This standard does not purport to address all of the safety concerns, if any, associated with its use. It is the responsibility of the user of this standard to establish appropriate safety and health practices and determine the applicability of regulatory limitations prior to use.*

## 2. Referenced Documents

2.1 *ASTM Standards:*<sup>2</sup>

- E 1 Specification for ASTM Liquid-in-Glass Thermometers
- E 128 Test Method for Maximum Pore Diameter and Permeability of Rigid Porous Filters for Laboratory Use

## 3. Summary of Test Method

3.1 The sample is dissolved in a mixture consisting of 50 volume % methyl ethyl ketone and 50 volume % toluene. The solution is cooled to  $-32^{\circ}\text{C}$  ( $-25^{\circ}\text{F}$ ) to precipitate the wax, then filtered. The solvent extractables content is determined by evaporating the solvent from the filtrate and weighing the residue.

## 4. Significance and Use

4.1 The solvent extractables in a wax may have significant effects on several of its properties such as strength, hardness, flexibility, scuff resistance, coefficient of friction, coefficient of expansion, melting point, and staining characteristics. Whether

these effects are desirable or undesirable depends on the intended use of the wax.

## 5. Apparatus

5.1 *Filter Stick and Assembly*, consisting of a 10-mm diameter sintered glass filter stick of 10 to 15  $\mu\text{m}$  maximum pore diameter as determined by the method in Appendix X1, provided with an air pressure inlet tube and delivery nozzle. It is provided with a ground-glass joint to fit a 25 by 170-mm test tube. The dimensions for a suitable filtration assembly are shown in Fig. 1.

NOTE 1—A metallic filter stick may be employed if desired. A filter stick<sup>3</sup> made of stainless steel and having a 12.7-mm (0.50-in.) disk of 10 to 15  $\mu\text{m}$  maximum pore diameter, as determined by Test Method E 128, has been found to be satisfactory. The metallic apparatus is inserted into a 25 by 150-mm test tube and held in place by means of a cork.

5.2 *Cooling Bath*, consisting of an insulated box with  $30 \pm 5\text{-mm}$  ( $1.2 \pm 0.2\text{-in.}$ ) holes in the center to accommodate any desired number of test tubes. The bath may be filled with a suitable medium such as kerosine, and may be cooled by circulating a refrigerant through coils, or by using solid carbon dioxide. A suitable cooling bath to accommodate three test tubes is shown in Fig. 2.

5.3 *Dropper Pipet*, dispensing device capable of delivering  $0.5 \pm 0.05\text{ g}$  of molten wax.

5.4 *Transfer Pipet*, or equivalent volume dispensing device, capable of delivering  $15 \pm 0.06\text{ mL}$ .

5.5 *Air Pressure Regulator*, designed to supply air to the filtration assembly (8.5) at sufficient pressure to give an even flow of filtrate. Either a conventional pressure-reducing valve or a mercury bubbler-type regulator has been found satisfactory. The latter type, illustrated in Fig. 3, consists of a 250-mL glass cylinder and a T-tube held in the cylinder by means of a

<sup>1</sup>This test method is under the jurisdiction of ASTM Committee D02 on Petroleum Products and Lubricants and is the direct responsibility of Subcommittee D02.10.0A on Physical/Chemical Properties.

Current edition approved Nov. 1, 2006. Published November 2006. Originally approved in 1973. Last previous edition approved in 2005 as D 3235-05.

<sup>2</sup>For referenced ASTM standards, visit the ASTM website, www.astm.org, or contact ASTM Customer Service at service@astm.org. For *Annual Book of ASTM Standards* volume information, refer to the standard's Document Summary page on the ASTM website.

<sup>3</sup>The sole source of supply of a suitable metal filter stick with designated porosity G known to the committee at this time is the Pall Trinity Micro Corp., Route 281, Cortland, NY 13045. A list of United Kingdom suppliers can be obtained from Energy Institute, 61 New Cavendish St., London, W1G 7AR, United Kingdom. If you are aware of alternative suppliers, please provide this information to ASTM International Headquarters. Your comments will receive careful consideration at a meeting of the responsible technical committee,<sup>1</sup> which you may attend.

\*A Summary of Changes section appears at the end of this standard.

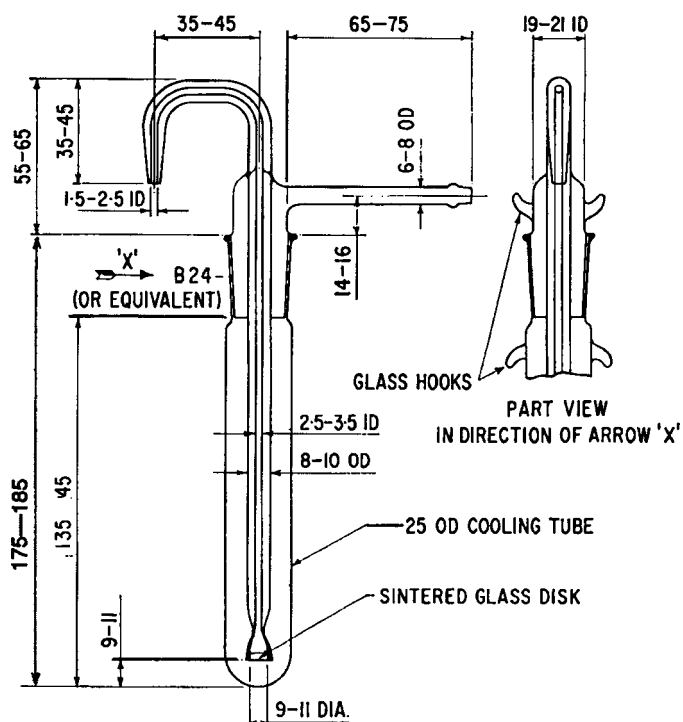

All dimensions are in millimetres.

FIG. 1 Filter Stick

rubber stopper grooved at the sides to permit the escape of excess air. The volume and pressure of the air supplied to the filtration assembly is regulated by the depth to which the T-tube is immersed in mercury at the bottom of the cylinder. Absorbent cotton placed in the space above the mercury prevents the loss of mercury by spattering. The air pressure regulator is connected to the filter stick and assembly by means of rubber tubing.

#### 5.6 Temperature Measuring Devices:

5.6.1 *Thermometers*, two, having a range as shown below and conforming to the requirements as prescribed in Specification E 1 or in the specifications for IP Standard Thermometers. One thermometer is required for the cold bath and a second thermometer is required for the sample solution.

Temperature Range	Thermometer Number	
	ASTM	IP
-37 to +21°C	71C	72C
-35 to +70°F	71F	72F

5.6.2 Temperature measuring devices other than those described in 5.6.1 are satisfactory for this test method, provided they exhibit the same temperature response as the equivalent mercury-in-glass thermometers.

5.7 *Weighing Bottles*, glass-stoppered, having a typical capacity of 15-25 mL.

5.8 *Evaporation Assembly*, consisting of an evaporating cabinet and connections, essentially as illustrated in Fig. 4, and capable of maintaining a temperature of  $35 \pm 1^\circ\text{C}$  ( $95 \pm 2^\circ\text{F}$ ) around the evaporation flasks. Construct the jets with an inside diameter of  $4 \pm 0.2$  mm for delivering a stream of clean, dry air vertically downward into the weighing bottle. Support each jet so that the tip is  $15 \pm 5$  mm above the surface of the liquid at the start of the evaporation. Supply purified air at the rate of

2 to 3 L/min per jet. One way to purify the air is to pass it through a tube of approximately 1-cm bore packed loosely to a height of approximately 20 cm with absorbent cotton. Periodically check the cleanliness of the air by evaporating 4 mL of the solvent mixture described in 6.3 by the procedure specified in 8.5. When the residue does not exceed 0.1 mg, the evaporation equipment is operating satisfactorily.

NOTE 2—Investigations by the European World Federation have indicated that improved precision may be achieved by individually calibrating each nozzle to deliver a flow rate of 2 to 3 L/min.

5.9 *Analytical Balance*, capable of reproducing weights to 0.1 mg.

5.10 *Wire Stirrer*—A piece of stiff made of iron, stainless steel, or Nichrome wire of about No. 20 Bands (0.9 mm in diameter) or 16 swg. gage, 250 mm long. A 10-mm diameter loop is formed at each end, and the loop at the bottom end is bent so that the plane of the loop is perpendicular to the wire.

## 6. Solvent

6.1 *Methyl Ethyl Ketone*, conforming to the specifications of the Committee on Analytical Reagents of the American Chemical Society.<sup>4</sup>

6.2 *Toluene*, conforming to the specifications of the Committee on Analytical Reagents of the American Chemical Society.<sup>4</sup>

<sup>4</sup> *Reagent Chemicals, American Chemical Society Specifications*, American Chemical Society, Washington, DC. For suggestions on the testing of reagents not listed by the American Chemical Society, see *Analar Standards for Laboratory Chemicals*, BDH Ltd., Poole, Dorset, U.K., and the *United States Pharmacopeia and National Formulary*, U.S. Pharmacopeial Convention, Inc. (USPC), Rockville, MD.

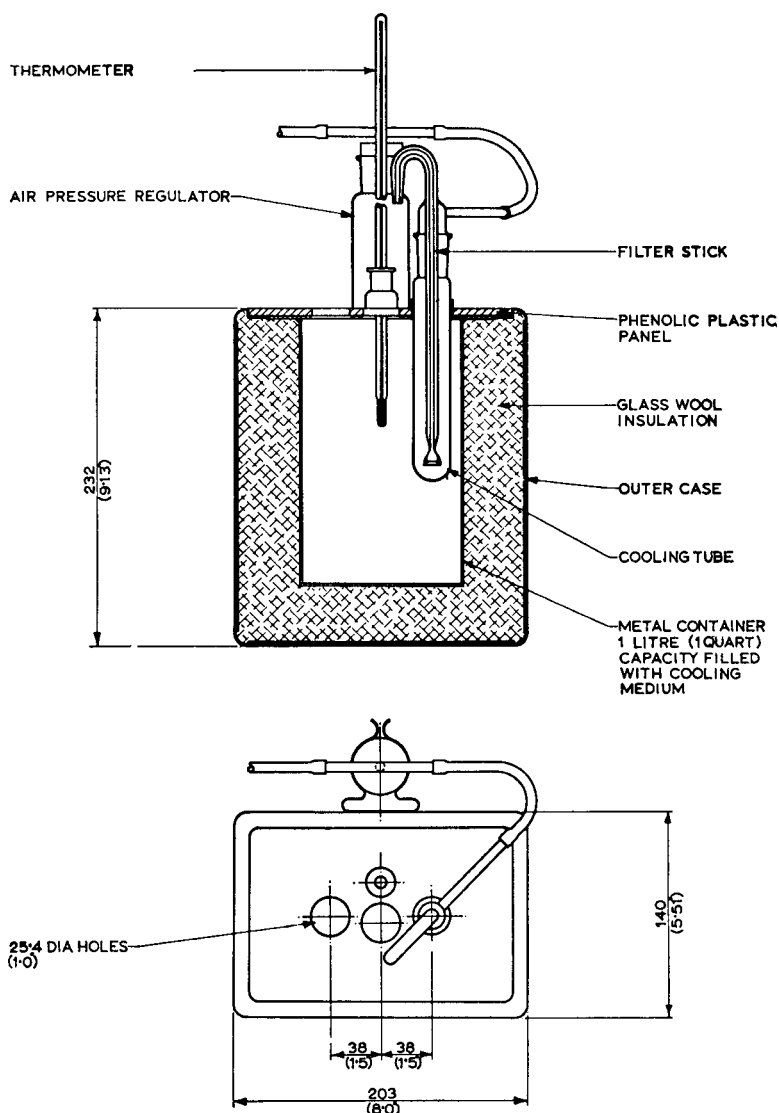

All dimensions are in millimetres (inches).

FIG. 2 Cooling Bath

6.3 *Solvent Mixture*—Prepare a mixture of 50 volume % methyl ethyl ketone and 50 volume % toluene.

6.4 Store the solvent mixture over anhydrous calcium sulfate (5 weight % of the solvent). Filter prior to use.

## 7. Sample

7.1 Obtain a representative portion by melting the entire sample and stirring thoroughly. This is necessary because the extractables may not be distributed uniformly throughout the solidified sample.

## 8. Procedure

8.1 Melt a representative portion of the sample, using a water bath or oven maintained at 70 to 100°C (158 to 212°F). As soon as the wax is completely melted, thoroughly mix. Preheat the pipet or equivalent measuring device in order to prevent the solidification of wax in the tip, and withdraw a

portion of the sample as soon as possible after the wax has melted. The mass of wax transferred to the test tube must be  $1.00 \pm 0.05$  g. Allow the test tube to cool, and weigh to at least the nearest 1 mg.

NOTE 3—The weight of a test tube which is cleaned by means of solvent will not vary to a significant extent. Therefore, a tare weight may be obtained and used repeatedly.

8.2 Pipet 15 mL of the solvent mixture into the test tube and place the latter just up to the level of its contents in a hot water or steam bath. Heat the solvent-wax mixture, stirring up and down with the wire stirrer, until a homogeneous solution is obtained. Exercise care to avoid loss of solvent by prolonged boiling.

NOTE 4—Very high-melting wax samples may not form clear solutions. Stir until the undissolved material is well dispersed as a fine cloud.

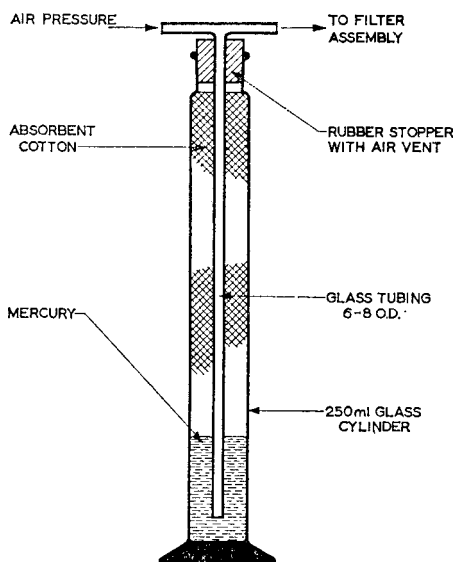

All dimensions are in millimetres.

FIG. 3 Air Pressure Regulator

8.2.1 Plunge the test tube into an 800-mL beaker of ice water and continue to stir until the contents are cold. Remove the stirrer. Remove the test tube from the ice bath, wipe dry on the outside with a cloth, and weigh to at least the nearest 0.1 g.

NOTE 5—During this operation the loss of solvent through vaporization should be less than 1 %. The weight of the solvent is, therefore, practically a constant, and after a few samples are weighed, this weight can be used as a constant factor.

8.3 Place the test tube containing the wax-solvent slurry in the cooling bath, which is maintained at  $-34.5 \pm 1.0^\circ\text{C}$  ( $-30.0 \pm 2.0^\circ\text{F}$ ). During this chilling operation, stir the contents of the tube by means of a temperature measurement device placed in the tube. It is important that stirring by means of the temperature measurement device be almost continuous, in order to maintain a slurry of uniform consistency as the wax precipitates. Do not allow the wax to set up on the walls of the cooling vessel nor permit any lumps of wax crystals to form. Continue stirring until the temperature reaches  $-31.7 \pm 0.3^\circ\text{C}$  ( $-25.0 \pm 0.5^\circ\text{F}$ ).

8.4 Remove the temperature measurement device from the tube and allow it to drain momentarily into the tube, then immediately immerse in the mixture the clean, dry filter stick, which has previously been cooled by placing it in a test tube and holding at  $-34.5 \pm 1.0^\circ\text{C}$  ( $-30.0 \pm 2.0^\circ\text{F}$ ) in the cooling bath for a minimum of 10 min. Seat the ground-glass joint of the filter so as to make an airtight seal. Place an unstoppered weighing bottle, previously weighed together with the glass stopper to the nearest 0.1 mg, under the delivery nozzle of the filtration assembly.

NOTE 6—Take every precaution to ensure the accuracy of the weight of the stoppered weighing bottle. Prior to determining this weight, rinse the clean, dry weighing bottle and stopper with the solvent mixture described in 6.3, wipe dry on the outside with a cloth, and place in the evaporation assembly to dry for about 5 min. Then remove the weighing bottle and stopper, place near the balance, and allow to stand for 10 min prior to weighing. Stopper the bottle during this cooling period. Once the weighing bottle and stopper have been dried in the evaporation assembly,

lift only with forceps. Take care to remove and replace the glass stopper with a light touch.

8.5 Apply air pressure to the filtration assembly and immediately collect about 4 mL of filtrate in the weighing bottle. Release the air pressure to permit the liquid to drain back slowly from the delivery nozzle. Remove the weighing bottle immediately, and stopper and weigh to at least the nearest 10 mg without waiting for it to come to room temperature. Unstopper the weighing bottle and place it under one of the jets in the evaporation assembly maintained at  $35 \pm 1^\circ\text{C}$  ( $95 \pm 2^\circ\text{F}$ ), with the air jet centered inside the neck, and the tip  $15 \pm 5$  mm above the surface of the liquid. After the solvent has evaporated, which usually takes less than 30 min, remove the bottle, stopper, and place near the balance. Allow to stand for 10 min and weigh to the nearest 0.1 mg. Repeat the evaporation procedure, using 5 min evaporation periods, until the loss between successive weighings is not over 0.2 mg.

## 9. Calculation

9.1 Calculate the amount of extractables in the wax as follows:

$$\text{Solvent extractables, weight \%} = 100 AC/BD \quad (1)$$

where:

A = weight of extractables residue, g,

B = weight of wax sample, g,

C = weight of solvent, g, obtained by subtracting weight of test tube plus wax sample (8.1) from weight of test tube and contents (8.2), and

D = weight of solvent evaporated, in g, obtained by subtracting weight of weighing bottle plus extractables residue from weight of weighing bottle plus filtrate (8.5).

## 10. Report

10.1 Report the result as solvent extractables, weight %, Test Method D 3235. If the result is negative, report as zero.

## 11. Precision and Bias

11.1 The precision of this test method as determined by statistical examination of interlaboratory results is as follows:

11.1.1 *Repeatability*—The difference between two test results, obtained by the same operator with the same apparatus under constant operating conditions on identical test material would, in the long run, in the normal and correct operation of the test method, exceed the following values only in one case in twenty:

Range	Repeatability
15 to 55 %	2 %

11.1.2 *Reproducibility*—The difference between two single and independent results obtained by different operators working in different laboratories on identical test material would, in the long run, in the normal and correct operation of the test method, exceed the following values only in one case in twenty:

Range	Reproducibility
15 to 55 %	5 %

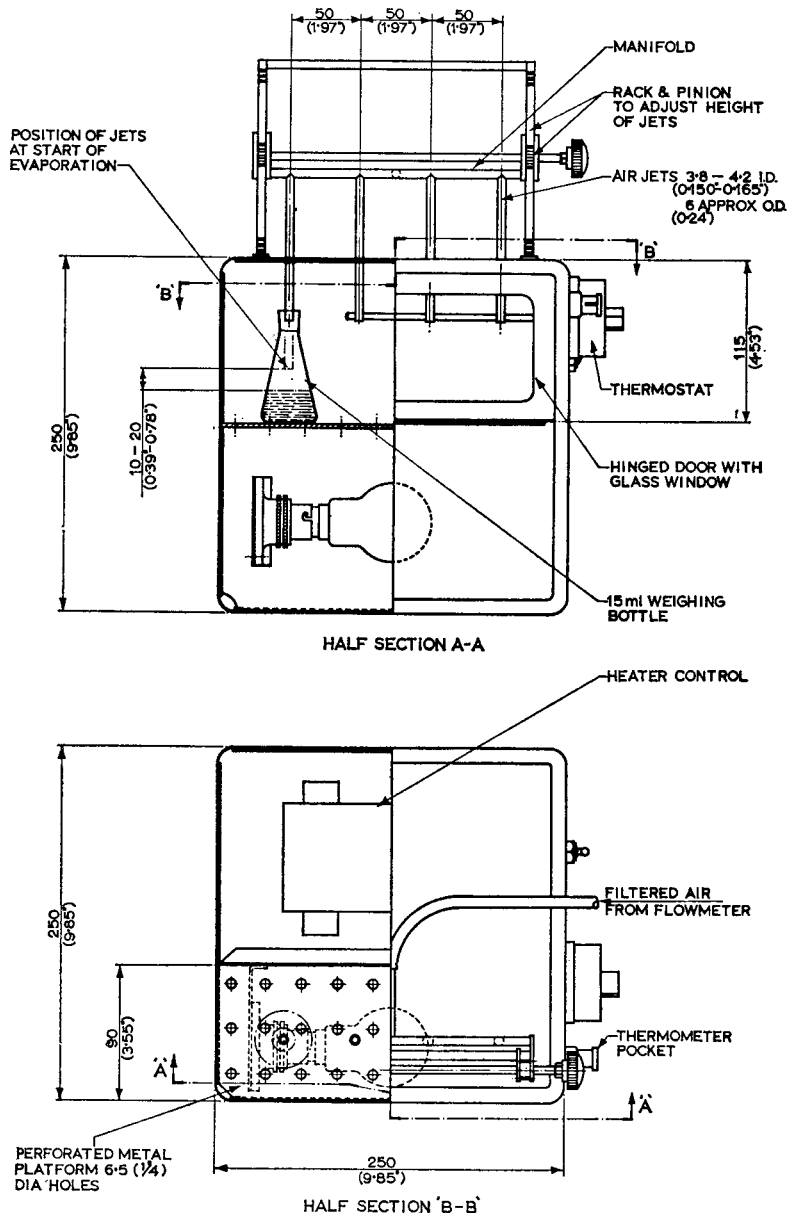

All dimensions are in millimetres (inches).

FIG. 4 Evaporation Assembly

11.2 The procedure in this test method has no bias because the value of solvent extractables can be defined only in terms of a test method.

12. Keywords

12.1 petroleum waxes; solvent extractables; wax

APPENDIX

(Nonmandatory Information)

**X1. TEST METHOD OF TEST FOR MEASUREMENT OF MAXIMUM PORE DIAMETER OF RIGID POROUS FILTERS**

**X1.1 Scope**

X1.1.1 This test method covers the determination of the acceptability of porous filter sticks used for filtration in Test Method D 3235. This method establishes the maximum pore diameter and also provides a means of detecting and measuring changes which occur from continued use.

**X1.2. Terminology**

X1.2.1 *Definitions:*

X1.2.1.1 *maximum pore diameter*—the diameter in nanometres of the largest opening in the filter.

*Discussion*—It is recognized that the maximum pore diameter as defined herein does not necessarily indicate the physical dimensions of the largest pore in the filter. It is further recognized that the pores are highly irregular in shape. Because of the irregularity in shape and other phenomena characteristic of filtration, a filter may be expected to retain all particles larger than the maximum pore diameter as defined and determined herein, and will generally retain particles which are much smaller than the determined diameter.

**X1.3 Summary of Test Method**

X1.3.1 The filter is cleaned and wetted with water. It is then immersed in water and air pressure is applied against its upper surface until the first bubble of air passes through the filter. The maximum pore diameter is calculated from the surface tension of water and the applied pressure.

**X1.4 Apparatus**

X1.4.1 *Pressure Measuring Device*, mercury filled manometer or equivalent, capable of measuring pressures in increments of 0.5 mm of Hg.

X1.4.2 *Air Supply*, clean and filtered.

X1.4.3 *Air Pressure Regulator*, needle-valve type.

X1.4.4 *Drying Oven*.

**X1.5 Procedure**

X1.5.1 Clean the filter sticks by soaking in concentrated hydrochloric acid, and then wash them with distilled water. Rinse with acetone, air dry, and place in drying oven at 220°F (105°C) for 30 min.

X1.5.2 Thoroughly wet the clean filter to be tested by soaking it in distilled water.

X1.5.3 Assemble the apparatus as shown in Fig. X1.1. Apply pressure slowly from a source of clean air.

X1.5.4 Immerse the filter just below the surface of the water.

NOTE X1.1—If a head of liquid exists above the surface of the filter, the back pressure produced must be deducted from the observed pressure.

X1.5.5 Increase the air pressure to about 10 mm Hg (or equivalent pressure value if using different units) below the acceptable pressure limit and then at a slow uniform rate equivalent to about 3 mm Hg/min until the first bubble passes through the filter. This can be conveniently observed by placing the beaker or test tube over a mirror. Read the pressure measuring device when the first bubble passes off the underside of the filter.

**X1.6 Calculation**

X1.6.1 Calculate the pore diameter as follows:

$$D = 2180/p \tag{X1.1}$$

where:

$D$  = pore diameter, nm, and

$p$  = pressure reading, mm Hg.

NOTE X1.2—From this equation, pressure corresponding to the upper and lower limits of the specified pore diameters can be calculated. These pressures may be used for acceptance testing.

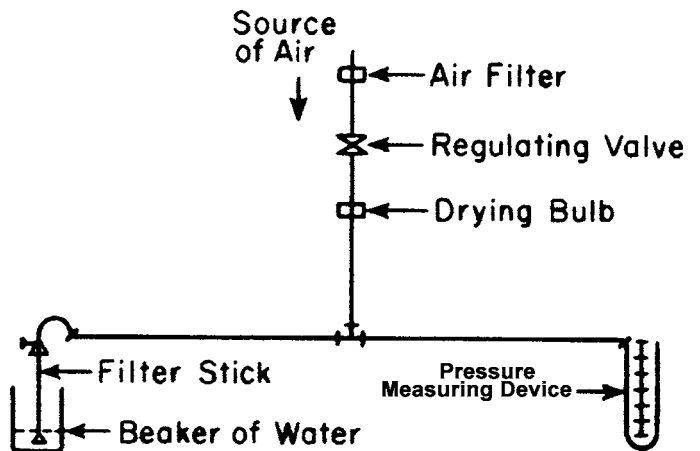

FIG. X1.1 Assembly of Apparatus for Checking Pore Diameter of Filter Sticks



**SUMMARY OF CHANGES**

Subcommittee D02.10.0A has identified the location of selected changes to this standard since the last issue (D 3235–05) that may impact the use of this standard. (Approved Nov. 1, 2006.)

- (1) Revised **8.1.**
- (2) Revised **8.2.1.**
- (3) Revised **8.3.**
- (4) Revised **8.4.**
- (5) Revised **8.5.**

Subcommittee D02.10.0A has identified the location of selected changes to this standard since the last issue (D 3235–04) that may impact the use of this standard. (Approved Nov. 1, 2005.)

- (1) Added **5.6** and **5.6.2.**
- (2) Renumbered previous 5.6 as **5.6.1.**
- (3) Revised **5.2, 5.7, 5.9, 8.3, and 8.4.**

*ASTM International takes no position respecting the validity of any patent rights asserted in connection with any item mentioned in this standard. Users of this standard are expressly advised that determination of the validity of any such patent rights, and the risk of infringement of such rights, are entirely their own responsibility.*

*This standard is subject to revision at any time by the responsible technical committee and must be reviewed every five years and if not revised, either reapproved or withdrawn. Your comments are invited either for revision of this standard or for additional standards and should be addressed to ASTM International Headquarters. Your comments will receive careful consideration at a meeting of the responsible technical committee, which you may attend. If you feel that your comments have not received a fair hearing you should make your views known to the ASTM Committee on Standards, at the address shown below.*

*This standard is copyrighted by ASTM International, 100 Barr Harbor Drive, PO Box C700, West Conshohocken, PA 19428-2959, United States. Individual reprints (single or multiple copies) of this standard may be obtained by contacting ASTM at the above address or at 610-832-9585 (phone), 610-832-9555 (fax), or [service@astm.org](mailto:service@astm.org) (e-mail); or through the ASTM website ([www.astm.org](http://www.astm.org)).*