



Standard Test Method for Rust-Preventing Characteristics of Steam Turbine Oil in the Presence of Water (Horizontal Disk Method)¹

This standard is issued under the fixed designation D3603; the number immediately following the designation indicates the year of original adoption or, in the case of revision, the year of last revision. A number in parentheses indicates the year of last reapproval. A superscript epsilon (ϵ) indicates an editorial change since the last revision or reapproval.

1. Scope

1.1 This test method covers the ability of steam-turbine oils to prevent the rusting of horizontal and vertical ferrous surfaces when water becomes mixed with the oil.

1.2 The values stated in SI units are to be regarded as standard. The values given in parentheses are for information only.

1.3 *This standard does not purport to address all of the safety concerns, if any, associated with its use. It is the responsibility of the user of this standard to establish appropriate safety and health practices and determine the applicability of regulatory limitations prior to use.*

2. Referenced Documents

2.1 ASTM Standards:²

A108 Specification for Steel Bar, Carbon and Alloy, Cold-Finished

A240/A240M Specification for Chromium and Chromium-Nickel Stainless Steel Plate, Sheet, and Strip for Pressure Vessels and for General Applications

D91 Test Method for Precipitation Number of Lubricating Oils

D665 Test Method for Rust-Preventing Characteristics of Inhibited Mineral Oil in the Presence of Water

D1193 Specification for Reagent Water

E1 Specification for ASTM Liquid-in-Glass Thermometers

2.2 Other Standards:

IP 60/80 Specification for Petroleum Spirit³

SAE 30304 Steel, Corrosion-Resistant, Sheet, Strip, and

Plate, 19Cr - 9.2Ni⁴

BS 970:Part 1:1983 Specification for wrought steels for mechanical and allied engineering purposes. General inspection and testing procedures and specific requirements for carbon, carbon manganese, alloy and stainless steels⁵

BS 871:1981 Specification for abrasive papers and cloths

3. Summary of Test Method

3.1 The test method involves completely immersing a horizontal steel disk and vertical steel cylinder in a stirred mixture of 275 mL of the oil under test and 25 mL of distilled water (water conforming to Specification **D1193**, Type II) at a temperature at 60°C (140°F).

3.2 The horizontal specimen allows water to puddle on the surface, and the vertical specimen is continually washed with the oil-water mixture during the test.

3.3 The test is run for 6 h and the specimens are evaluated.

4. Significance and Use

4.1 Horizontal metal surfaces, on which water droplets tend to be retained, are more prone to rusting and corrosion than vertical or sloping surfaces. This test method is therefore more discriminating than Test Method **D665** (Procedure A), since it gives a separate evaluation of the oil on a horizontal and a vertical surface. The test method indicates the ability of oils to prevent rusting and corrosion of all ferrous surfaces in steam turbines under full flow and quasi-static conditions. It is used for specification of new oils.

5. Apparatus

5.1 **Oil Bath**—A thermostatically controlled liquid bath capable of maintaining a temperature in the oil sample of 60 ± 1°C (140 ± 2°F). The bath shall have a cover with holes to accommodate the test beakers.

NOTE 1—The bath used for Test Method **D665** may be used with slight modification, that is, the centers of the beaker holes are moved from 6.4 mm to 18.3 mm (¼ to 23/32 in.) from the axes of the stirrers.

¹ This test method is under the jurisdiction of ASTM Committee **D02** on Petroleum Products and Lubricants and is the direct responsibility of **D02.C0.02** on Corrosion and Water/Air Separability.

Current edition approved May 1, 2007. Published May 2007. Originally approved in 1977. Last previous edition approved in 2002 as D3603–93(2002). DOI: 10.1520/D3603-07.

² For referenced ASTM standards, visit the ASTM website, www.astm.org, or contact ASTM Customer Service at service@astm.org. For *Annual Book of ASTM Standards* volume information, refer to the standard's Document Summary page on the ASTM website.

³ Available from Energy Institute, 61 New Cavendish St., London, WIG 7AR, U.K., <http://www.energyinst.org.uk>.

⁴ Available from SAE World Headquarters, 400 Commonwealth Drive, Warrendale, PA 15096-0001.

⁵ BSI, British Standards, 389 Chiswick High Road, London W4 4AL, United Kingdom.

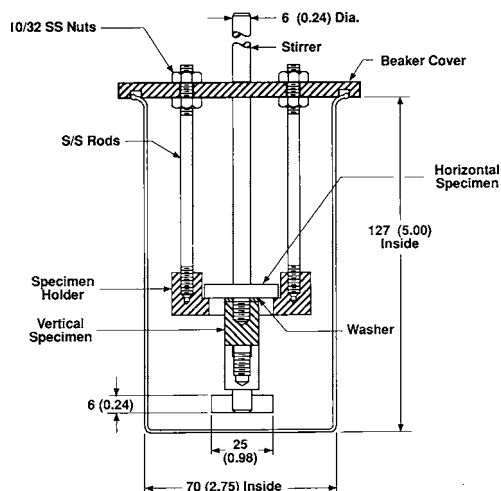

NOTE—All dimensions are in millimetres (inches).
FIG. 1 Rusting Test Apparatus

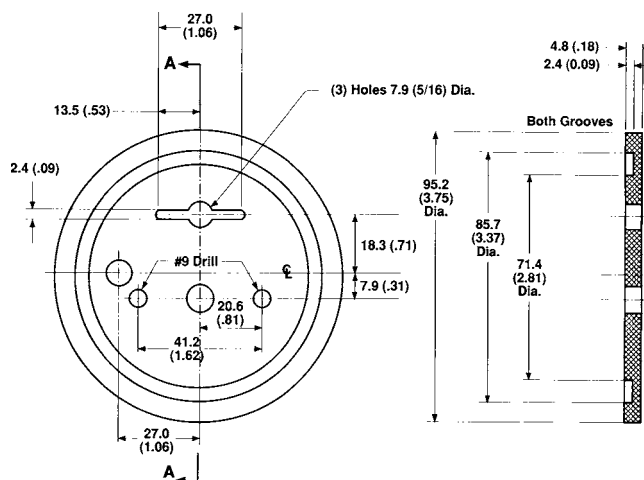

NOTE—All dimensions are in millimetres (inches).
FIG. 2 Beaker Cover

NOTE 2—To indicate the temperature, a thermometer conforming to the requirements of ASTM Thermometer 9C or 9F, or IP Thermometer 21C, as prescribed in Specification E1 should be used.

5.2 *Beaker*—A 400-mL, Berzelius-type, tall-form heat-resistant glass⁶ beaker without pourout, as shown in Fig. 1, approximately 127 mm (5 in.) in height measured from the inside bottom center and approximately 70 mm (2¾ in.) in inside diameter measured at the middle.

5.3 *Beaker Cover and Specimen Holder*—A flat beaker cover (Fig. 2) of methyl methacrylate resin or other fluid resistant material is kept in position by a suitable groove. Three holes are provided. Two are located on any diameter of the cover, one for a stirrer, and the other for attachment of a disk specimen to the underside of the cover for optional vapor phase testing. The third hole is for a thermometer, located on a diameter perpendicular to that of the other two holes. The outside of the polytetrafluoroethylene (PTFE) specimen holder (Fig. 3) is a square, but from the ends of one diagonal, two equal pieces of PTFE are cut off over the height of the holder. Two vertical threaded holes are made on the other diagonal of the square. The inside of the holder consists of two cylindrical holes, one on top of the other. Four horizontal holes are drilled 90° apart on the circumference where the two cylindrical holes meet. The PTFE specimen holder is connected to the beaker cover by two stainless steel holding rods (Fig. 4). Both ends of each holding rod are threaded. The surfaces between the threads are polished with No. 180 grit emery. The 12.7-mm threaded ends of the holding rods are screwed into the two vertical threaded holes of the specimen holder. The 19.0-mm threaded ends of the holding rods are connected to the beaker cover by putting them through two holes on a line perpendicular to the connection line of the centers of the earlier mentioned first and second hole of the beaker cover. Each holding rod is fastened by two 10-32 stainless steel nuts.

NOTE 3—An alternative design for the specimen holder assembly has also been used successfully. See Test Method D3603-82.

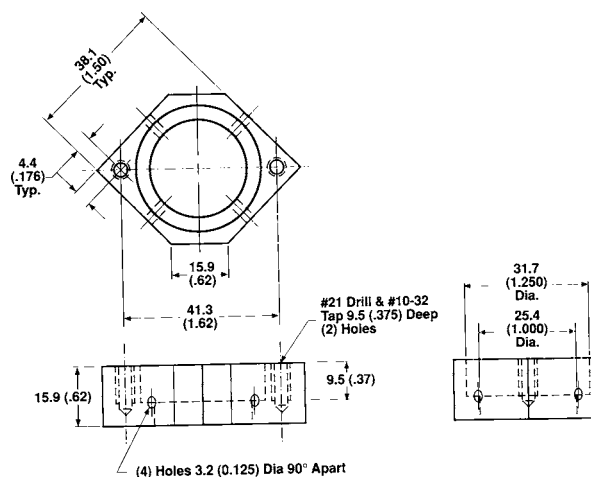

NOTE—All dimensions are in millimetres (inches).
FIG. 3 Specimen Holder

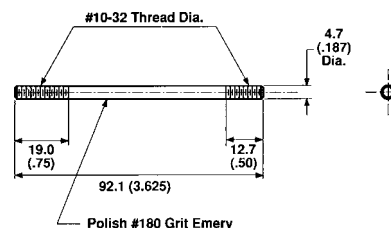

NOTE—All dimensions are in millimetres (inches).
FIG. 4 Holding Rod

5.4 *Stirrer*—A stirrer constructed entirely from stainless steel in the form of an inverted T (Fig. 5). A flat blade 25.4 by 6.1 by 0.6 mm (1 by 0.24 by 0.024 in.) shall be attached to a 6.1-mm (0.24-in.) rod in such a way that the blade is symmetrical with the rod and has its flat surface in the vertical plane.

NOTE 4—A suitable material is an 18 % chromium, 8 % nickel alloy steel conforming to Type 304 of ASTM Specification A240/A240M or SAE No. 30304, or BS 970: Part I:1983:302531.

⁶ Borosilicate glass is satisfactory for this purpose.

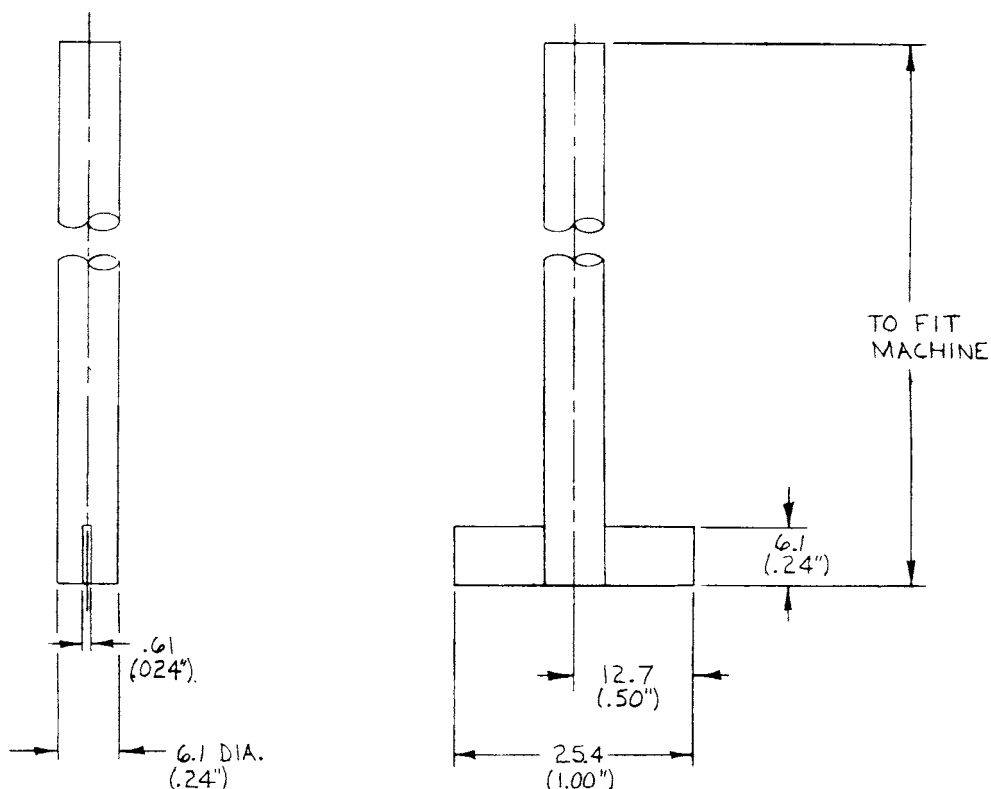

NOTE 1—All dimensions are in millimetres (inches).
 NOTE 2—¹²⁵ all over.
 NOTE 3—All dimensions ± 0.5 mm (0.02 in.).
 NOTE 4—Break all sharp corners.

FIG. 5 Stirrer

NOTE 5—If stainless steel is not obtainable, stirrers made of heat-resistant glass⁶ and having approximately the same dimensions as the stainless steel stirrers may be used.

5.5 *Stirring Apparatus*—Any convenient form of stirring apparatus capable of maintaining a speed of 1000 ± 50 r/min.

5.6 *Grinding and Polishing Equipment*—A CAMI 150-grit (99 μm) and a CAMI 240-grit (53.5 μm) in accordance with BS 871 or its equivalent, metalworking aluminum oxide abrasive cloth coat on a jeans backing (the corresponding European grades (FEPA) are P150J and P280J, respectively), a suitable chuck (Fig. 6) for holding the specimen, and a means of rotating the specimen at a speed of 1700 to 1800 r/min.

NOTE 6—CAMI (Coated Abrasives Manufacturers Institute) is a United States organization and FEPA (Federations of European Producers of Abrasives) is a European organization.

6. Reagents and Materials

6.1 *Cleaning Agents*—One of the following shall be used:

6.1.1 *ASTM Precipitation Naphtha*, conforming to Test Method D91. (**Warning**—Flammable. Health hazard.)

6.1.2 *Isooctane*, conforming to Annex II on Reference Materials and Blending Accessories (see Annex II, Reference Materials and Blending Accessories, Motor Section⁷). Previ-

ously used, unrusted specimens shall be stored in this reagent. (**Warning**—Flammable. Health hazard.)

6.1.3 *IP Petroleum Spirit*, conforming to IP 60/80. (**Warning**—Flammable. Health hazard.)

7. Test Specimens and Their Preparation

7.1 The horizontal and vertical specimens (Fig. 7 and Fig. 8, respectively) are attached to one another, separated by a 2.4-mm ($\frac{3}{32}$ -in.) fluorocarbon washer (Fig. 9). A methyl methacrylate cap (Fig. 10) is attached to the vertical specimen for handling.

7.2 The horizontal specimen when new shall be 30.2 mm ($1\frac{3}{16}$ in.) in diameter and 4.8 mm ($\frac{3}{16}$ in.) thick, with a 6.4-mm ($\frac{1}{4}$ -in.) central threaded shaft 9.5 mm ($\frac{3}{8}$ in.) long. Specimens should be discarded when they reach a thickness of 1.6 mm ($\frac{1}{16}$ in.) after repeated use.

7.3 The vertical specimen when new shall be 12.7 mm ($\frac{1}{2}$ in.) in diameter and 15.9 mm ($\frac{5}{8}$ in.) in length exclusive of the 9.5-mm ($\frac{3}{8}$ -in.) threaded shaft which screws into the 15.9-mm plastic cap. Specimens should be discarded when they reach a diameter of 9.5 mm after repeated use.

7.4 Both specimens shall be made of steel conforming to Grade 1018 of Specification A108, or to BS 970: 1955-EN3B.

NOTE 7—When making a check test, the steel specimen that showed rust should not be reused. Specimens that repeatedly show rust in tests of various oils may be imperfect. Such specimens should be used with oils

⁷ Last printed in the 1996 Annual Book of ASTM Standards, Vol 05.04.

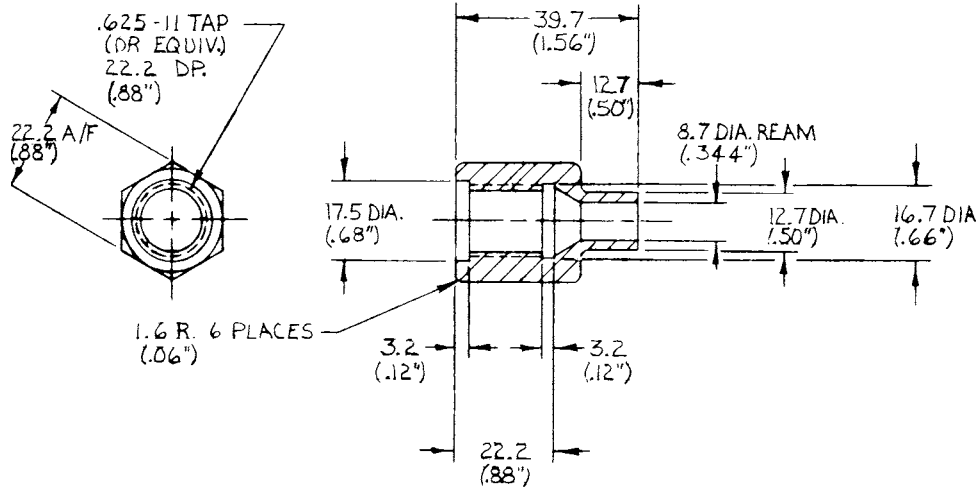

NOTE 1—Tap dimensions are in inches. All others are in millimetres (inches).
 NOTE 2—¹²⁵ all over.
 NOTE 3—All dimensions \pm 0.5 mm (0.02 in.).
 NOTE 4—Break all sharp corners.

FIG. 6 Chuck for Polishing Test Specimens

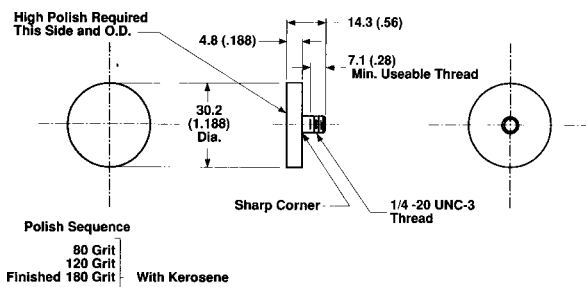

NOTE—All dimensions are in millimetres (inches).
 FIG. 7 Horizontal Specimen

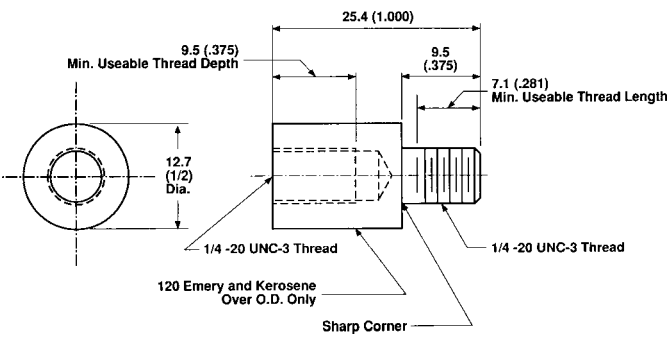

NOTE—All dimensions are in millimetres (inches).
 FIG. 8 Vertical Specimen

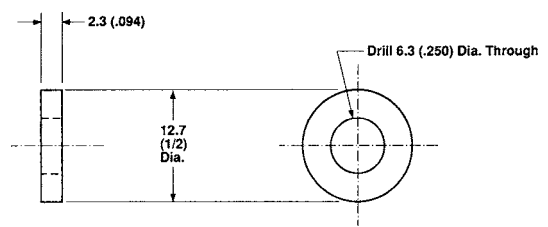

NOTE—All dimensions are in millimetres (inches).
 FIG. 9 Washer

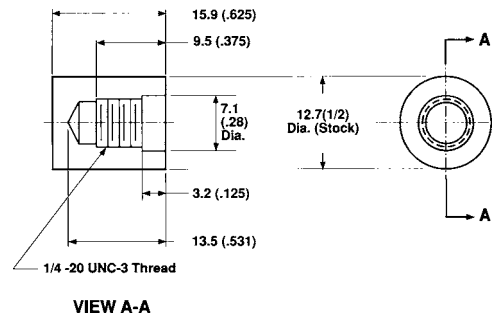

NOTE—All other dimensions are in millimetres (inches).
 FIG. 10 Cap

known to pass the test. If rusting occurs in repeat tests, these specimens should be discarded.

7.5 Both specimens, either new or from a previous test (previously used unrusted specimens shall be stored in *isooctane*) shall be prepared as described in 7.6 and 7.7.

7.6 *Preliminary Grinding*—If the specimens have been used previously and are free from rust or other irregularities, the preliminary grinding may be omitted, and they may be subjected only to final polishing as prescribed in 7.7. If the

specimens are new or if any part of their surfaces show rust or other irregularities, clean them with ASTM precipitation naphtha or *isooctane* or IP 60/80 petroleum spirit and grind with medium 150-grit aluminum oxide cloth to remove all irregularities, pits, and scratches, as determined by visual inspection.

7.6.1 The specimen shall not be touched with the hands at any stage after cleaning with naphtha or *isooctane* or the petroleum spirit (which precedes either preliminary grinding or final polishing) until the test is completed. Forceps or a clean, lintless cloth may be used.

7.7 *Final Polishing*—Just before the test is to be made, polish the specimens with 240-grit aluminum oxide cloth. If

the preliminary grinding has just been completed, stop the motor which rotates the specimen. Otherwise, remove the specimen from the *isooctane* (previously used unrusted specimens shall be stored in this reagent), dry with a clean cloth, and place in the chuck.

7.7.1 Vertical Specimen—When polishing a vertical specimen, rub a new piece of 240-grit aluminum oxide cloth longitudinally over the static specimen until the entire cylindrical surface shows visible scratches. Rotate the specimen at a speed of 1700 to 1800 r/min and polish with a strip of 240-grit aluminum oxide cloth by wrapping it halfway around the specimen, and applying a firm but gentle downward pull to the loose ends of the cloth to produce a uniform finely scratched surface free from longitudinal scratches. Carry out the final stages of the polishing with new cloth. Use only the cylindrical surface in evaluating the test. However, the flat end and shoulder adjacent to the threaded shaft should be rust free, not necessarily polished, at the start of the test.

7.7.2 Horizontal Specimen—When polishing a horizontal specimen, rub a new piece of 240-grit aluminum oxide cloth across the flat test surface until the entire surface shows visible straight scratches. Rotate the specimen at a speed of 1700 to 1800 r/min and polish with a strip of 240-grit aluminum oxide cloth by pressing firmly against the cloth with the flat of the thumb and slowly moving it back and forth, across the flat surface to produce a uniform finely scratched surface free from straight scratches. Carry out the final stages of the polishing with new cloth. Use only the flat surface in evaluating the test. However, the edge and surface adjacent to the shaft should be rust free, not necessarily polished, at the start of the test.

7.8 Assembly of Specimens—Before assembly, clean the fluorocarbon washer and plastic cap with ASTM precipitation naphtha, *isooctane*, or 60/80 petroleum spirit, and dry thoroughly. Attach the cap to the vertical specimen, and attach the horizontal specimen to the vertical specimen, separating them with the fluorocarbon washer.

NOTE 8—Fig. 1 shows the arrangement of the apparatus.

8. Procedure

8.1 Clean the beaker in accordance with good laboratory procedure (NOTE 9) cleaning solution, wash with distilled water to remove the acid completely, and dry in an oven. Clean the stainless steel stirrer and plastic beaker cover and specimen holder assembly with ASTM precipitation naphtha, *isooctane*, or 60/80 petroleum spirit, and dry thoroughly at room temperature.

NOTE 9—In cases of dispute the parties to the dispute to agree on a glassware cleaning procedure. However the round robin was conducted with glassware cleaned with chromic acid.

8.2 Pour 275 mL of the oil to be tested into the beaker and place the beaker in the oil bath held at a temperature that will maintain $60 \pm 1^\circ\text{C}$ ($140 \pm 2^\circ\text{F}$) in the oil sample. Insert the beaker into a hole in the bath cover so that the beaker is suspended with the rim resting on the bath cover. The oil level in the bath shall not be below the oil level in the test beaker. Place the polished specimens in the specimen holder with the vertical specimen beneath the horizontal specimen, and lower the assembly into the oil sample until the cover rests on the

beaker rim. Insert the thermometer in the beaker so that the bulb is positioned approximately 20 mm ($\frac{3}{4}$ in.) from the bottom of the beaker. Place the stirrer in position so that it does not touch the specimens when turning and is within 2.0 mm (0.08 in.) of the bottom of the beaker. Start the stirrer and stir until the temperature of the sample reaches $60 \pm 1^\circ\text{C}$.

8.3 Continue stirring for 30 min to ensure complete wetting of the steel specimens. With the stirrer in motion, remove the thermometer temporarily and add 25 mL of distilled water by pipet through this hole, discharging the water on the bottom of the beaker. Resume stirring at a speed of 1000 ± 50 r/min for 6 h from the time the water was added, maintaining the temperature of the oil-water mixture at $60 \pm 1^\circ\text{C}$ ($140 \pm 2^\circ\text{F}$). Stop stirring at the end of the 6-h period, remove the specimens, allow to drain, and then wash with ASTM precipitation naphtha, or *isooctane*, or 60/80 petroleum spirit. If desired, the specimens may be preserved by lacquering.

9. Report

9.1 All inspections at the end of the test to determine the condition of specimens shall be performed without magnification under normal light. For the purpose of this test, normal light is considered to be illumination of about 646 lx (60 footcandles).

9.2 In order to report an oil as passing or failing, the test must be conducted in duplicate. An oil shall be reported as passing the test if both specimens meet the passing criterion in 9.3. An oil shall be reported as failing the test if duplicate specimens fail according to 9.3. If one specimen fails while the other passes, tests on two additional specimens shall be made. If either of these latter specimens fails, the oil shall be reported as failing the test. If neither of these latter specimens shows rusting, the oil shall be reported as passing the test.

9.3 The specimens shall be evaluated separately. If a specimen shows *any rust spot or streak* visible, without magnification under normal light, within the test surface area as defined below, it shall be reported as failing. If a specimen shows no rust with the test surface area, it shall be reported as passing even though rusting is observed outside this area (that is, at the edges).

	Test Surface Area
Horizontal specimen	Area contained by a circle 2.0 mm (0.08 in.) from the edge.
Vertical specimen	Area contained by boundaries 1.0 mm (0.04 in.) from the top and bottom edges.

10. Precision and Bias

10.1 Precision—It is not practical to specify the precision of the procedure in Test Method D3603 for measuring rust-preventing characteristics because the results of the test are only intended to give a pass/fail rating to the oil being tested.

10.2 Bias—Since there is no accepted reference material suitable for determining the bias for the procedure in Test Method D3603 for measuring rust-preventing characteristics, no statement on bias is being made.

11. Keywords

11.1 horizontal disk method; rust-preventing characteristics; steam-turbine oils

ASTM International takes no position respecting the validity of any patent rights asserted in connection with any item mentioned in this standard. Users of this standard are expressly advised that determination of the validity of any such patent rights, and the risk of infringement of such rights, are entirely their own responsibility.

This standard is subject to revision at any time by the responsible technical committee and must be reviewed every five years and if not revised, either reapproved or withdrawn. Your comments are invited either for revision of this standard or for additional standards and should be addressed to ASTM International Headquarters. Your comments will receive careful consideration at a meeting of the responsible technical committee, which you may attend. If you feel that your comments have not received a fair hearing you should make your views known to the ASTM Committee on Standards, at the address shown below.

This standard is copyrighted by ASTM International, 100 Barr Harbor Drive, PO Box C700, West Conshohocken, PA 19428-2959, United States. Individual reprints (single or multiple copies) of this standard may be obtained by contacting ASTM at the above address or at 610-832-9585 (phone), 610-832-9555 (fax), or service@astm.org (e-mail); or through the ASTM website (www.astm.org).