



Standard Practice for Sampling Pitch¹

This standard is issued under the fixed designation D4296; the number immediately following the designation indicates the year of original adoption or, in the case of revision, the year of last revision. A number in parentheses indicates the year of last reapproval. A superscript epsilon (ϵ) indicates an editorial change since the last revision or reapproval.

1. Scope

1.1 This practice covers procedures for sampling pitch at points of manufacture, storage, and delivery.

1.2 The values stated in SI units are to be regarded as standard. The values in parentheses are for information only.

1.3 *This standard does not purport to address all of the safety concerns, if any, associated with its use. It is the responsibility of the user of this standard to establish appropriate safety and health practices and determine the applicability of regulatory limitations prior to use.* Specific warning statements are given in Section 11.

2. Terminology

2.1 Definitions:

2.1.1 *bulk sample*—a large sample, either from one place or made up of several incremental samples of the same material.

2.1.2 *composite sample*—a thoroughly mixed gross sample.

2.1.3 *gross sample*—a large sample made up of several portions (increments) of a mass of material.

2.1.4 *increment*—a portion of a material to be combined with other portions of the same material to provide a larger sample which will represent the whole material.

2.1.5 *representative sample*—a part of a homogeneous material, or a part of the composited and mixed portions of a material, which carries all the true properties and physical characteristics of the whole material.

2.1.6 *sample*—a part taken as representative of a whole material.

3. Summary of Practice

3.1 Samples of liquid pitches are taken from process lines, storage, and shipment containers in increments required to prepare a representative sample for testing.

¹ This practice is under the jurisdiction of ASTM Committee D02 on Petroleum Products and Lubricants and is the direct responsibility of Subcommittee D02.05 on Properties of Fuels, Petroleum Coke and Carbon Material.

Current edition approved Oct. 1, 2009. Published November 2009. Originally approved in 1983. Last previous edition approved in 2004 as D4296–83(2004). DOI: 10.1520/D4296-83R09.

3.2 Samples of solid pitches are taken from loading systems, storage, and shipment containers in increments required to prepare a representative sample for testing.

4. Significance and Use

4.1 Sampling is as important as testing. If the sampling is improperly done, the sample of the material will be in error, and the analysis will not represent the true properties of the material, and it may be impossible or impracticable to take another sample; whereas, if the sample is properly taken and the analysis is in error, another analysis can readily be made of the original sample.

4.2 Samples may be taken for either of the following two purposes:

4.2.1 To represent as nearly as possible an average of the bulk of the materials sampled, or

4.2.2 To ascertain the maximum variation in characteristics which the material possesses.

4.3 A good sampling plan has the following characteristics:

4.3.1 It protects the consumer against the acceptance of a bad batch of material.

4.3.2 It protects the producer against the rejection of a good batch of material.

4.3.3 It gives long-range protection to the consumer.

4.3.4 It encourages the producer to keep his process in control.

4.3.5 It minimizes the cost of sampling, inspection of testing, and administration.

4.3.6 It provides information concerning the quality of the product.

4.4 *Sampling Integrity*—When one takes a sample, one is attempting to represent a batch or lot of material with that sample. Different forms of pitch, and pitch in different types of containers, need to have different sampling plans and appropriate sampling equipment. Each sampling plan should be designed so that it accomplishes its objective, which is to ascertain the characteristics or quality of a batch or lot of material.

5. Selection of Samples

5.1 Pitches shall be sampled by the producer at the point of manufacture or storage, and at such time as to allow the tests controlling acceptance or rejection of quality, as specified by the consumer, to be made in advance of a shipment.

5.2 Samples of pitches shall be taken by the consumer from the shipment containers immediately upon delivery and receipt and tests controlling acceptance or rejection of quality, as described by the consumer’s specifications, shall be made as soon as possible.

6. Size of Samples

6.1 The sample size of liquid materials shall be as follows:

6.1.1 From process lines, 1 L (1 qt).

6.1.2 From bulk storage, 1 L (1 qt) or 1-L aliquot of composite sample.

6.1.3 From bulk shipment containers, 1 L (1 qt) or 1-L aliquot of composite sample.

6.1.4 From barrels or drums, 0.5 L (1 pt) or 0.5-L aliquot of composite sample.

6.2 The sample size of solid materials shall be as follows:

6.2.1 From storage area, 4 L (1 gal) or 4-L aliquot of composite sample.

6.2.2 From bulk shipment containers, 4 L (1 gal) aliquot of composite sample.

6.2.3 From barrels or drums, 0.5-L (1 pt) or 0.5-L aliquot of composite sample.

7. Collection of Gross Sample

7.1 A collection of gross sample represents a lot or batch of material and is composed of a number of increments.

7.1.1 Collect the increments regularly and systematically, so that the entire quantity of pitch sampled will be represented proportionately in the gross sample, and with such frequency that a gross sample of the required amount will be collected.

8. Size of Increments

8.1 To collect samples, use a shovel or specially designed tool or mechanical means for taking equal portions or increments. When samples are collected from the surface of loaded shipments, the gross sample shall consist of nine increments of approximately equal quantity. When sampling from piles, conveyer belts, and so forth, the gross sample shall consist of not less than 25 nor more than 50 increments of approximately equal quantity.

9. Protection and Preservation of Samples

9.1 Sample containers shall be new or reusable containers which can be thoroughly cleaned with a solvent and wiped dry with a clean dry cloth.

9.2 Care shall be taken to prevent the sample from becoming contaminated. Immediately after filling, hot liquid sample containers shall be positively covered, but not tightly sealed. Containers of solid materials shall be tightly and positively sealed.

9.3 While sampling during inclement weather, attention shall be paid to prevent water from dropping into the hot liquid sample or samples of solid materials.

9.4 Immediately after filling and sealing, the sampling containers shall be properly marked for identification with a suitable pencil on the container itself, not on the lid.

10. Apparatus

10.1 Sampling Equipment for Liquid Materials:

10.1.1 If so equipped, pipe lines and storage tanks may be sampled from valves installed in the lines or up the side of the tanks. A typical tank valve is shown in Fig. 1, and suitable line valves are illustrated in Fig. 2 and Fig. 3.

10.1.2 For sampling tank trucks, a pipe connection with attached sample valve similar to the one shown in Fig. 2 may be inserted between the outlet pipe and unloading line.

10.1.3 A weighted sample bottle similar to those shown in Fig. 4 and Fig. 5, or a “thief sampler” as shown in Fig. 6, or a “dip sampler” similar to that shown in Fig. 7, may be used to sample production and storage tanks, tank cars, and tank trucks.

10.1.4 A “tube” or “thief” sampler may be used to sample materials in drums or barrels.

10.2 Sampling Equipment for Solid Materials:

10.2.1 Samples from loading systems may be taken with a shovel, metal or plastic scoop, or metal can.

10.2.2 A shovel may be used to sample storage bins, pitch piles, pitch bays, hopper cars, and dump trucks.

10.2.3 A sampling spear as shown in Fig. 8 may be used to sample materials in drums, barrels, bags, and silos.

10.3 Sampling Containers:

10.3.1 Containers for liquid materials shall be wide-mouth cans with line screw caps or triple-seal friction-top cans.

10.3.2 Containers for formed pitches or crushed solid pitch shall be triple-seal friction-top cans, sealable plastic or paper cartons with inert inside coating, plastic sacks placed in other containers suitable for handling, or substantial strength paper bag which can be stapled closed.

10.4 Mixing Equipment for Solid Materials:

10.4.1 Section of clean canvas or plastic sheet of sufficient size to contain a large bulk sample which is to be reduced by mixing and quartering.

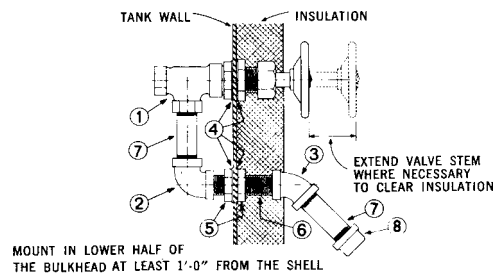

REF. No.	DESCRIPTION	No. REQ.
1	3/4" "VOGT" P-9844 STEEL ANGLE VALVE OR SIMILAR, PANEL MOUNTED	1
2	3/4" STEEL OR MALL. IRON 90° ELBOW	1
3	3/4" STEEL OR MALL. IRON 45° ELBOW	1
4	ASBESTOS GASKETS SNUG ON THREAD OR WOUND WITH YARN	4
5	3/4" 150# SCREWED M. I. LOCKNUT	2
6	3/4" x 3 1/2" ± PARALLEL THREADED STEEL PIPE NIPPLE (CUT FROM 3/4" STD. TANK NIPPLE IF OTHERWISE UNOBTAINABLE)	1
7	3/4" x 3" THREADED STEEL PIPE NIPPLE	2
8	3/4" MALL. IRON PIPE CAP	1

FIG. 1 Typical Submerged Sampling Device

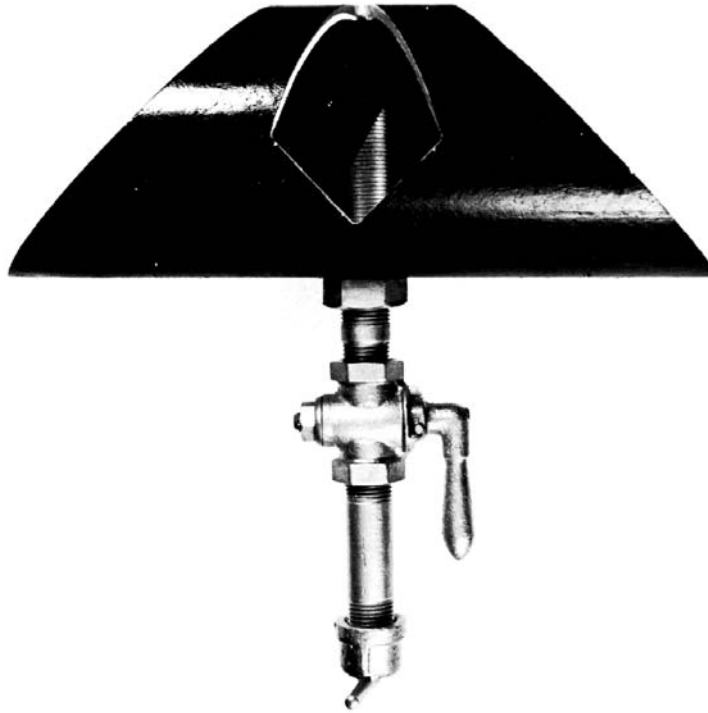

FIG. 2 In-Line Sampling Device

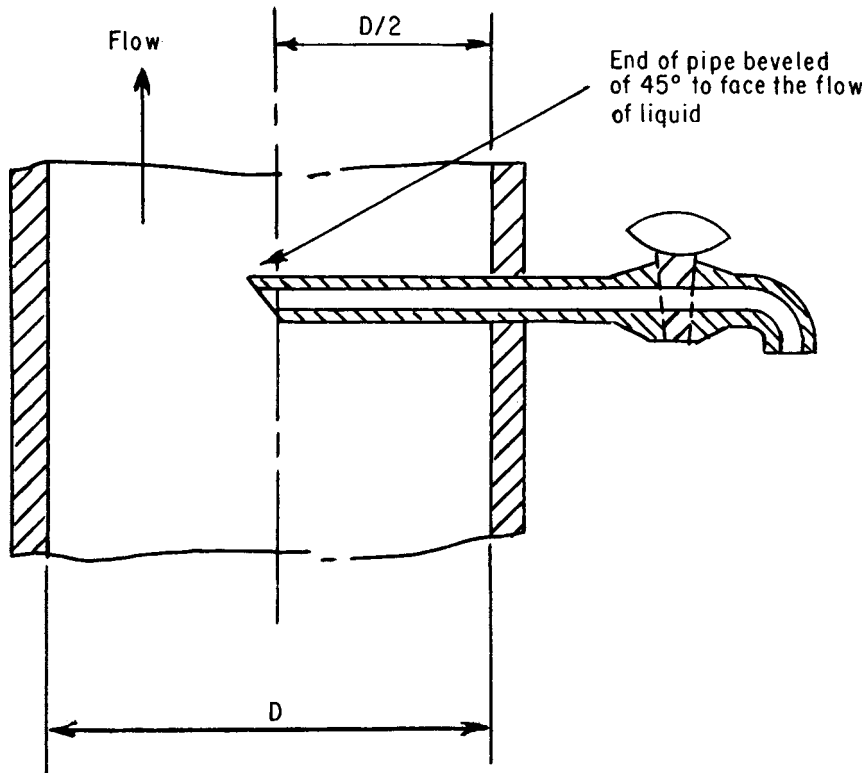

FIG. 3 Pipeline Sampler

10.4.2 A “riffle” as shown in Fig. 9 may be used for reducing gross samples to smaller sizes for testing.

10.4.3 A “shovel” may be used to reduce gross samples to smaller sizes by mixing and quartering as shown in Fig. 10.

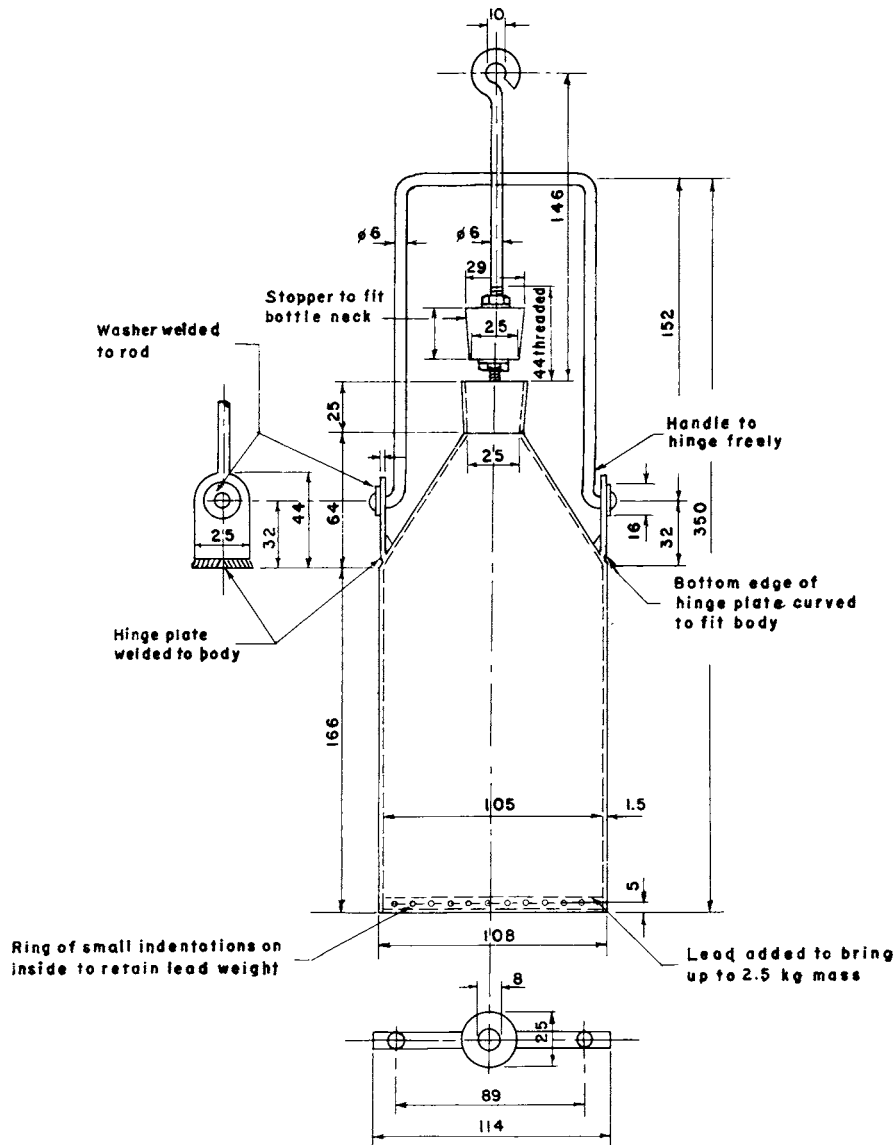

FIG. 4 Weighted Sampling Can

10.5 Mixing Equipment for Liquid Materials:

10.5.1 Sample sizes of 4 L (1 gal) or less can be mixed by thorough stirring with a metal rod or wide blade metal paddle.

10.5.2 A heavy duty electric stirrer is recommended for sample volumes over 4 L (1 gal) to 20 L (5 gal) in size.

11. Hazards

11.1 The sampler shall wear protective clothing, goggles, and rubber or heat-resistant gloves to protect oneself from accidental contact with hot liquid pitch.

11.2 For prolonged exposure to the presence of pitch vapors or pitch dust, a suitable respirator mask should be worn to avoid inhalation of pitch vapors or dust. It is recommended that an appropriate barrier cream be applied to exposed areas of the skin.

11.3 Sampling from rail cars shall be avoided when there is a possibility of shunting operations taking place. It is recommended that flags be placed on both ends of the car to prevent accidental movement during sampling.

11.4 It is recommended that no fewer than two persons be present when samples are taken from hot bulk vessels such as storage tanks, tank cars, and tank trucks.

12. Sampling Liquid Pitch

12.1 The following three sampling methods are recommended for sampling vertical tanks not capable of being agitated:

12.1.1 *Sample-Valve Method*—Locate valves, with easy and safe access provided, on the side of the tank with the first in the top third of the tank, but no higher than 1 m (3 ft) from the top; the second in the middle of the tank; and the third in the bottom third of the tank, but no lower than 1.1 m (3½ ft) from the bottom. A recommended design of the sample valve is shown in Fig. 1. Draw a minimum of 4 L (1 gal) of the product from each sample valve for test or composite.

12.1.2 *Thief Sampling Method*—Take samples at the top, middle and lower sections of the tank by lowering a thief sampler into the material. A satisfactory type with instructions

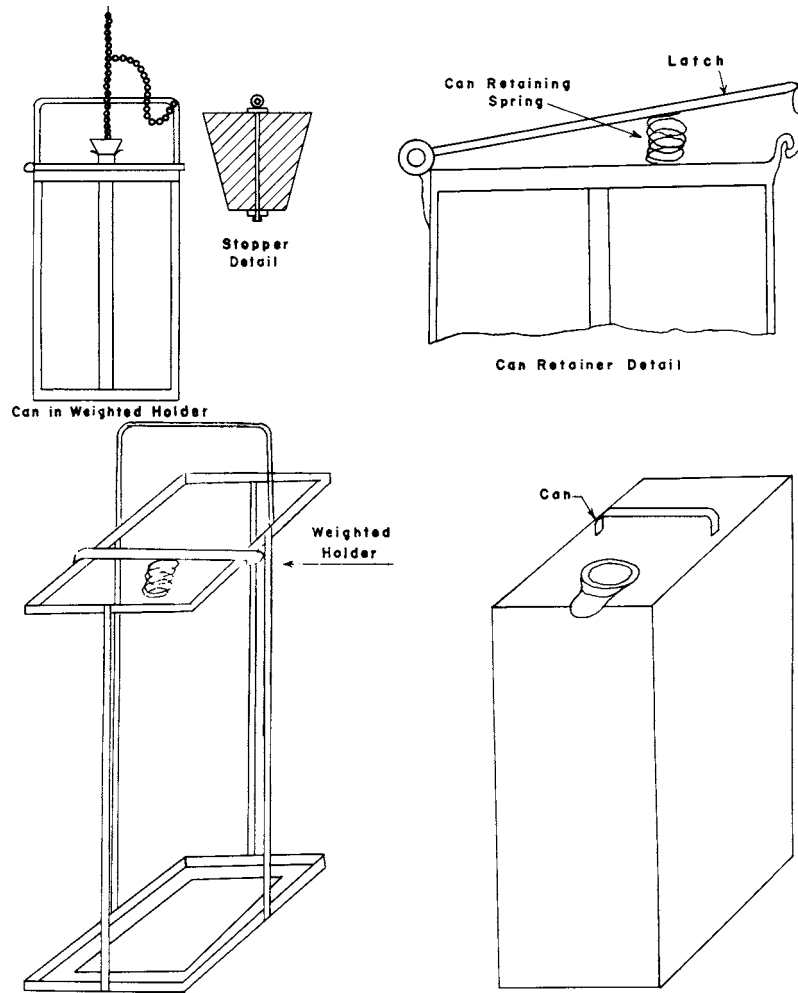

NOTE—This type sampler is lowered into the tank with the stopper in place. When the desired depth is reached, the stopper is removed by means of the attached wire, cord, or chain and the container allowed to fill. Complete filling is indicated by the cessation of bubbles of air from the can at the surface of the liquid. The sampler is then withdrawn from the tank and the contents poured into the clean sampler container. A clean can (bottle) must be used for each sample taken.

FIG. 5 Throw-Away Container Sampler

for use is shown in Fig. 6. The samples may be tested separately or combined and mixed thoroughly for a composite analysis.

12.1.3 *Weighted Sample Bottle Method*—Take samples at the top, middle, and lower sections of the tank by lowering the bottle into the material. Two types of weighted sampling bottles are illustrated in Fig. 4 and Fig. 5.

12.1.3.1 The essential feature of the method is to drop the stoppered bottle into the material to the desired depth, and then pull the stopper by means of an attached chain. When the material fills the bottle, lift out of the liquid and empty into a clean container. Drain the bottle as completely as possible, re-insert the stopper, lower into the material to the next sampling depth.

12.1.3.2 Normally, there is not enough undrained residue from the first sample to affect the properties of the next sample taken from a different level. However, if substantial material difference is suspected at various levels of the material, discard the first of successive samples to rinse the bottle and then return the bottle to the same level for another sample.

12.1.3.3 The three samples may be tested separately for consistency to detect stratification or they may be combined, thoroughly mixed, and a 1 to 4-L (¼ to 1-gal) aliquot of the composite taken for determining the average characteristics of the material.

12.2 *Sampling Bulk Storage Tanks Equipped with Mechanical Agitators or Recirculating Pumps*—When the tank is equipped with operating mechanical agitators or recirculating pumping systems which are performing adequate mixing of the tank contents, take a single sample by any of the methods described in 12.1.1, 12.1.2, or 12.1.3 to use for test purposes.

12.3 *Sampling Tank Cars and Tank Trucks:*

12.3.1 Samples of hot liquid materials may be taken by the dip method using a clean wide-mouth or friction-top can in a suitable holder or firmly attached to a metal rod. One such dip apparatus is shown in Fig. 7. Quickly lower the dip sample about 0.3 m (1 ft) below the surface of the liquid and carefully remove. Use a clean container to take each sample, and then transfer the material sampled to another clean container for retention and testing.

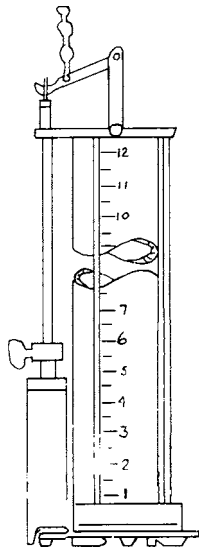

NOTE—This type sampler is lowered into the tank with bottom valve open (there is no top closure). When the desired depth is reached, the lowering chain is given a snap tug which closes the bottom valve. The sampler is then withdrawn from the tank and the contents transferred to the sample container. This sampler may be used for repetitive sampling in the same tank.

FIG. 6 Thief Sampler

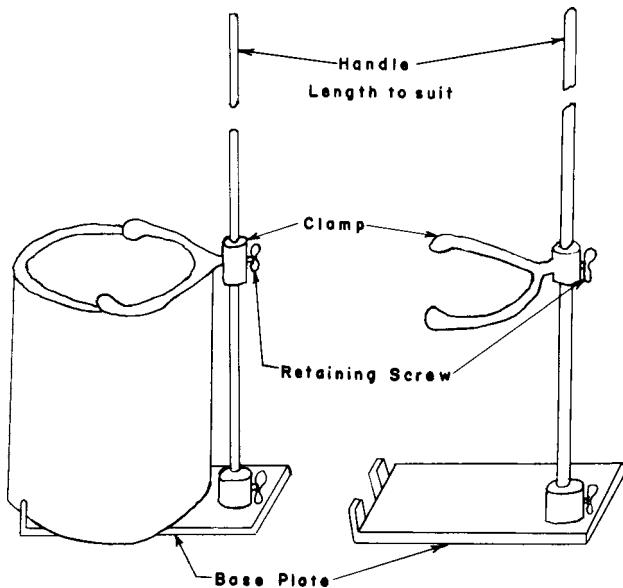

NOTE—Sampler with can secured in place is rapidly lowered into tank to desired depth and allowed to fill with sample. The sampler is then withdrawn from the tank and the contents transferred to the sample container. A clean container *must* be used to take each sample.

FIG. 7 Dip Sampler

12.3.2 If incremental samples are required for subsequent composite, samples may be taken as described in 12.1.2 or 12.1.3.

12.3.3 When tank cars or tank trucks are being loaded or unloaded, samples may conveniently be taken from the pipe line through which material is flowing by insertion of a sampling pipe into the rising section of the pipe line on the

discharge side of the pump, or in a completely filled line in which gravity creates the material's flow.

12.3.3.1 A suitable in-line sampling pipe is shown in Fig. 2 and Fig. 3. Turn the opening of the sampling pipe to face the flow of the liquid. Provide the pipe with a valve or plug cock and discharge into a sample receiver. Before the sample is taken, draw 4 L (1 gal) of the material from the pipe valve and discard.

12.3.3.2 Take samples of 1 L (1 qt) at such frequency during the loading or unloading to provide a 4 to 8-L (1 to 2-gal) composite of the material. At the completion of the loading or unloading, thoroughly mix the collected sample and take a 0.5 to 4-L ($\frac{1}{8}$ to 1-gal) portion for testing.

12.4 Sampling from Drums or Barrels:

12.4.1 High-softening point pitches poured into drums for storage and shipment will solidify at ambient temperatures and sampling should be made in accordance with the procedure in 12.5.

12.4.2 Some soft pitches stored or shipped in drums or barrels will be semi-solid at ambient temperatures, and will permit the insertion of drum heaters. Drum "Band Heaters" are also useful in heating materials in semisolid condition. After thorough heating, the material can then be sampled.

12.4.3 Secure samples of liquid pitch from barrels or drums by "Tube" or "Thief" sampling by taking 1 L (1 qt) of material from the packages. When the lot of material to be sampled is obviously from a single run or batch, select one or more packages at random for sampling according to the following table:

Packages in Batch or Shipment	Packages to be Sampled
1 to 10	1
10 to 30	2
30 to 50	3
50 to 100	4

12.4.3.1 Take samples from at least 80 mm (3 in.) below the surface and at least 80 mm (3 in.) from the side of the container.

12.4.4 Reheat all samples, and if more than one sample is taken, combine them into a composite from which a 1 L (1 qt) portion shall be taken for examination.

12.4.5 If more than one batch is encountered, and it is not possible to differentiate between batches, it may be necessary to examine each sample separately, or take a higher proportionate number of samples per number of packages for individual or composite analysis.

13. Sampling Solid Pitch

13.1 Sampling Formed Pitches (Rod, Pencil, Prell, Pellet, Flake, or Chipped).

13.1.1 From Discharge Media (Shute, Pipe, Conveyer, etc.) to Container—Take incremental samples from discharge at a frequency and size determined by the rate of production to provide a 20-L (5-gal) representative composite of a production batch or shipment. Reduce this bulk composite by mixing and quartering or by riffing to provide a 4-L (1-gal) sample for analysis.

13.1.2 From Open Hopper Car, Dump Truck, or Storage Bin—Take a sample from across the top of the open hopper car,

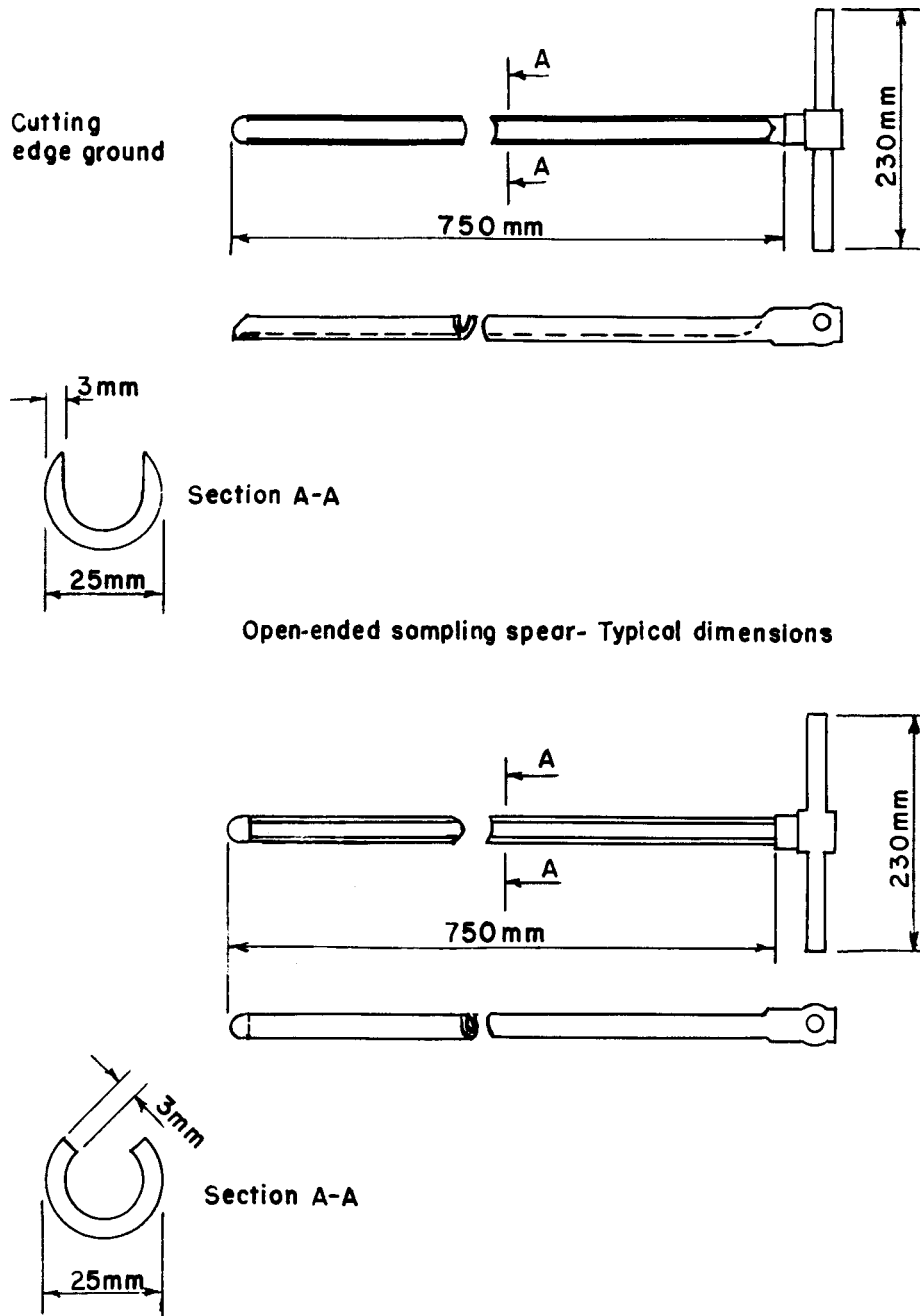

FIG. 8 Closed-End Sampling Spear—Typical Dimensions

dump truck, or storage bin, at least 300 mm (12 in.) below the surface. Take samples from each of the sampling point locations of the open hopper car as indicated in Fig. 11; sample at least three points across the surface of a dump truck; and take a sample from three or more points across the area of the material in a storage bin.

13.1.2.1 The size of the sample shall be at least 4 L (1 gal). The samples may be examined separately for particular properties, composited by area, or combined, mixed thoroughly, and reduced by quartering or riffing to provide a 4 L (1 gal) composite of the total material for evaluation of total properties.

13.1.2.2 If the weather results in a safety hazard or possible moisture contamination when sampling from the top of a

hopper car, the material may be sampled from the bottom of the car as it drops through the hopper door while being unloaded. Take two randomly selected 4 L (1 gal) samples from the flowing stream of each compartment.

13.1.3 *From Closed-Hopper Car*—Take samples from an equal number of hatches of each compartment. The number of hatches per compartment may vary from two to four on three compartment hopper cars. Some large tonnage closed-hopper cars may have two to three compartments with longitudinal center lids.

13.1.3.1 Take a sample from under the hatch cover or lid at least 0.3 m (12 in.) below the surface of the material. Scoop or shovel the sample, taking representative fines with the larger pieces, to fill a 4 L (1 gal) can. For routine sampling, it is

Dimensions in millimetres

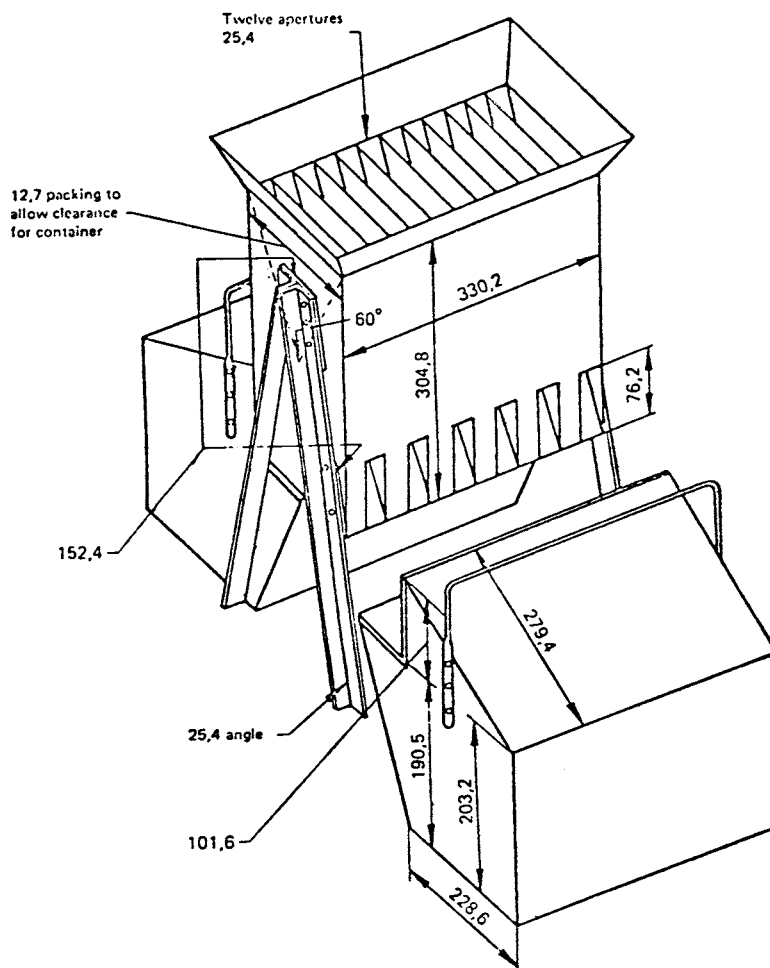

FIG. 9 Riffle for Sample Dividing of Material of Approximate Diameter 5 mm

sufficient to sample cars with hatches from only one hatch per compartment. However, for referee sampling, sample two or more hatches per compartment. Sample cars with longitudinal lids from one to three points along the length of the compartment.

13.1.3.2 The samples may be examined separately for particular properties, composited by compartment, or combined, mixed thoroughly, and reduced by quartering or riffling to provide a 4-L (1-gal) composite of the total material for evaluation of total properties.

13.1.3.3 If the weather results in a safety hazard or possible moisture contaminations when sampling from under the open hatch covers or lids, the material may be sampled from the bottom of the car as it drops through the hopper door while being unloaded. Take two randomly selected 4-L (1-gal) samples from the flowing stream of each compartment.

13.1.4 *From Pneumatic Truck*—Pneumatic trucks can be sampled only at the discharge end of the air hose or pipe. Take at least three 1 to 4-L (¼ to 1-gal) grab samples from the discharge stream. Composite and mix the incremental samples, and reduce by quartering or riffling if necessary to provide about a 4-L sample for testing.

13.1.5 *Sampling a Barge Loading*—The average of the analyses of each hopper car or dump truck loaded into a barge may be used for the barge analysis.

13.1.5.1 If a barge is loaded from a pitch pile or other source where the overall analysis has not been determined, take a grab sample from the loading conveyer every 15 to 30 min. Measure the size of the increment sample so as to provide a bulk sample of at least 45 kg (100 lb) by the end of the loading. Reduce the barge sample by mixing and quartering as illustrated in Fig. 10, or by riffling, to provide a 4-L (1-gal) composite sample for testing.

13.1.6 *Sampling a Barge Unloading*—Sample barges unloaded by conveyer from any point on the conveyer, or from its discharge, in the same manner as described in 13.1.5.1.

13.1.6.1 Sample material unloaded from a barge by “Clam Shell” into hopper cars or dump trucks from the cars or trucks as outlined in 13.1.2. The samples of all cars or trucks may be combined for a composite analysis, or the individual samples tested separately for a calculated average analysis of the barge load.

13.2 *Sampling Solidified Bay Pitch.*

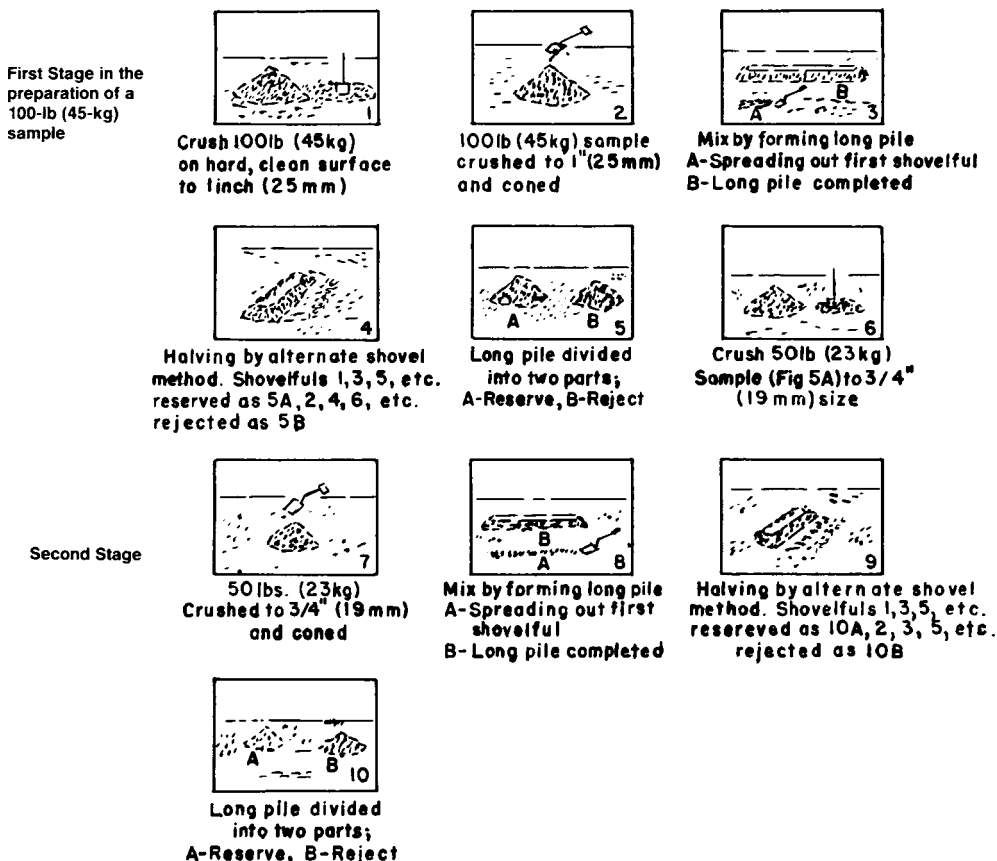

NOTE 1—Select a hard, clean surface free of cracks and protected from rain, snow, wind, and beating sun. Do not let cinders, sand, chippings from floor, or any other foreign matter get into the sample. Protect sample from loss or gain in moisture.

NOTE 2—Necessary tools include shovel, tamper, and steel plate, broom, and rake. Use rake for taking over pitch when crushing it, so that all lumps will be crushed. Sweep floor clean of all discarded pitch after each time sample is halved.

FIG. 10 Preparation of a 100-lb (227 Kg) Sample

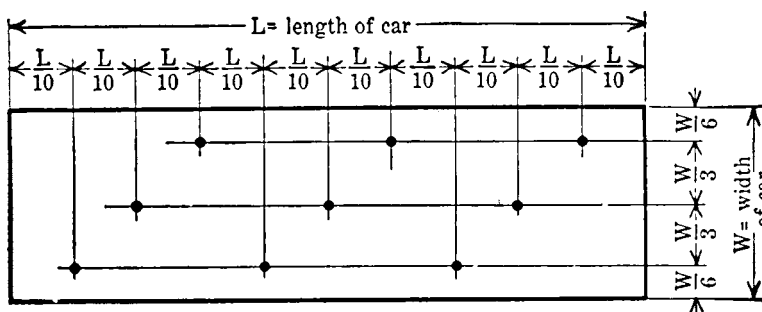

FIG. 11 Location of Sampling Points from Exposed Surface of Car

13.2.1 To obtain representative samples from any area, it is necessary to take samples of the whole depth of the mass. Break up a 600-mm (2-ft) square area in at least three points in the bay with a pick and hammer. Select points evenly spaced so that a cross section of the bay will be represented. Break up the pitch to its entire depth to the floor of the bay. Crush the large lumps of pitch with a hammer to about 50 mm (2 in.) or less. Fill a 4-L (1-gal) can from each sampling point, taking all the fines with the lumps as the material is scooped out.

13.2.2 Combine the 4-L (1-gal) samples and reduce by riffing to provide a 4 L composite. Crush the composited pitch

through a ball or hammer mill to 6.5 mm (1/4 in.) or less and remove a 1-L (1-qt) portion for testing.

13.3 Sampling Crushed (Lump) Bay Pitch.

13.3.1 From Pitch Pile—Take a 4-L (1-gal) sample from several points across the pile, the number of points depending upon the mass. Take samples at least 0.3 m (1 ft) below the surface of the material. Combine the 4-L (1-gal) samples and reduce by mixing and quartering (See Fig. 10), crushing the large lumps to 50 mm (2 in.) or less during the process. Prepare a well-mixed 20-L (5-gal) composite from which a 4-L (1-gal) portion shall be removed for milling and analysis.

13.3.2 *From Barge Loading or Unloading*—Sampling may be made from the loading or unloading conveyer as instructed in 13.1.5.1, or if unloaded by clam shell, sampled in accordance with 13.1.6.1.

13.4 *Sampling All Types of Formed Pitch from Silo.*

13.4.1 If the material in the silo is known to be of a single batch and be homogeneous in properties throughout the mass, then a grab sample taken from the surface would be satisfactory for analysis.

13.4.2 If the material is known or is suspected of being of mixed properties, the most practical method for sampling is with a “Sampling Spear” (Fig. 8). Extend the spear into the material at various depths, preferably below the surface, near the middle, and near the bottom. Composite the samples, mix thoroughly, and reduce to 4-L (1-gal), if necessary, for laboratory examination.

13.5 *Sampling from Drums or Barrels (Solidified Pitch):*

13.5.1 Pitch may have been filled, in a liquid state, into a barrel or drum and allowed to solidify. It is usually impracticable to melt the material in order to sample it. Expose the pitch by removing the lid or splitting the drum or barrel with an axe. Chip away about 80 mm (3 in.) from any surface area, and knock out a portion to fill a ½-L (1-qt) can for analysis.

13.5.2 Where the lot of material to be sampled is obviously from a single run or batch, select one or more packages at random for sampling according to the table in 12.4.3.

13.5.3 If more than one package is sampled, combine all samples to form a composite from which a ½-L (1-qt) portion shall be taken for examination.

13.5.4 If more than one batch is encountered and it is not possible to differentiate between batches, it may be necessary to examine each sample separately, or take a higher propor-

tionate number of samples per number of packages for individual or composite analysis.

13.6 *Sampling from Bags, Drums or Barrels (Loose Formed Pitch)*—Scoop samples ½-L (1 qt) in size from the open containers, and from packages selected at random according to the table in 12.4.3. Perform examination of samples as instructed in 13.5.1.

14. Sampling Report

14.1 Sample identification shall contain all the essential information to the sample. The following particulars are suggested:

14.1.1 Date and time of sample.

14.1.2 Form of pitch (for example: rod, pencil, prell, flake, liquid, and so forth).

14.1.3 Name of producer if sample is from a shipment receipt.

14.1.4 Source or identification designation of container, or both (for example, car number, bay number, truck, drum, bag, belt discharge, and so forth).

14.1.5 Nature of sample (for example, composite, sectional, layer, single, and so forth).

14.1.6 Equipment used (for example, dip bottle, thief, spear, and so forth).

14.1.7 Frequency of sample, such as number of portions taken over a period of time.

14.1.8 Method of sample reduction (for example, riffle, quartering).

14.1.9 Comments on abnormalities such as weather conditions or obvious contamination.

15. Keywords

15.1 pitch; sample

ASTM International takes no position respecting the validity of any patent rights asserted in connection with any item mentioned in this standard. Users of this standard are expressly advised that determination of the validity of any such patent rights, and the risk of infringement of such rights, are entirely their own responsibility.

This standard is subject to revision at any time by the responsible technical committee and must be reviewed every five years and if not revised, either reapproved or withdrawn. Your comments are invited either for revision of this standard or for additional standards and should be addressed to ASTM International Headquarters. Your comments will receive careful consideration at a meeting of the responsible technical committee, which you may attend. If you feel that your comments have not received a fair hearing you should make your views known to the ASTM Committee on Standards, at the address shown below.

This standard is copyrighted by ASTM International, 100 Barr Harbor Drive, PO Box C700, West Conshohocken, PA 19428-2959, United States. Individual reprints (single or multiple copies) of this standard may be obtained by contacting ASTM at the above address or at 610-832-9585 (phone), 610-832-9555 (fax), or service@astm.org (e-mail); or through the ASTM website (www.astm.org).