



Designation: D4177 – 95 (Reapproved 2005)



Designation: Manual of Petroleum Measurement Standards (MPMS), Chapter 8.2

Standard Practice for Automatic Sampling of Petroleum and Petroleum Products¹

This standard is issued under the fixed designation D4177; the number immediately following the designation indicates the year of original adoption or, in the case of revision, the year of last revision. A number in parentheses indicates the year of last reapproval. A superscript epsilon (ϵ) indicates an editorial change since the last revision or reapproval.

This standard has been approved for use by agencies of the Department of Defense.

1. Scope

1.1 This practice covers information for the design, installation, testing, and operation of automated equipment for the extraction of representative samples of petroleum and petroleum products from a flowing stream and storing them in a sample receiver. If sampling is for the precise determination of volatility, use Practice [D5842](#) (API *MPMS* Chapter 8.4) in conjunction with this practice. For sample mixing, refer to Practice [D5854](#) (API *MPMS* Chapter 8.3). Petroleum products covered in this practice are considered to be a single phase and exhibit Newtonian characteristics at the point of sampling.

1.2 *Applicable Fluids*—This practice is applicable to petroleum and petroleum products with vapor pressures at sampling and storage temperatures less than or equal to 101 kPa (14.7 psi). Refer to [D5842](#) (API *MPMS* Chapter 8.4) when sampling for Reid vapor pressure (RVP) determination.

1.3 *Non-applicable Fluids*—Petroleum products whose vapor pressure at sampling and sample storage conditions are above 101 kPa (14.7 psi) and liquified gases (that is, LNG, LPG etc.) are not covered by this practice.

1.3.1 While the procedures covered by this practice will produce a representative sample of the flowing liquid into the sample receiver, specialized sample handling may be necessary to maintain sample integrity of more volatile materials at high temperatures or extended residence time in the receiver. Such handling requirements are not within the scope of this practice. Procedures for sampling these fluids are described in Practice [D1265](#), Test Method [D1145](#), and [GPA 2166](#).

1.4 [Annex A2](#) contains theoretical calculations for selecting the sampler probe location. [Annex A3](#) lists acceptance methodologies for sampling systems and components. [Annex A4](#) gives performance criteria for permanent installations, while [Annex A5](#) has the criteria for portable sampling units. [Annex](#)

[A6](#) provides sampler acceptance test data. [Appendix X1](#) is a design data sheet for automatic sampling systems. [Appendix X2](#) compares the percent sediment and water to unloading time period.

1.5 The values stated in SI units are to be regarded as standard. The values given in parentheses are for information only.

2. Referenced Documents

2.1 *ASTM Standards*:²

- [D923](#) Practices for Sampling Electrical Insulating Liquids
- [D1145](#) Test Method for Sampling Natural Gas³
- [D1265](#) Practice for Sampling Liquefied Petroleum (LP) Gases, Manual Method
- [D4057](#) Practice for Manual Sampling of Petroleum and Petroleum Products
- [D4928](#) Test Methods for Water in Crude Oils by Coulometric Karl Fischer Titration
- [D5842](#) Practice for Sampling and Handling of Fuels for Volatility Measurement
- [D5854](#) Practice for Mixing and Handling of Liquid Samples of Petroleum and Petroleum Products

2.2 *API Standards*:⁴

- API Manual of Petroleum Measurement Standards, Chapters 3, 4, 5, 6, and 10
- MPMS* Chapter 8.1 Practice for Manual Sampling of Petroleum and Petroleum Products (ASTM Practice [D4057](#))
- MPMS* Chapter 8.3 Practice for Mixing and Handling of Liquid Samples of Petroleum and Petroleum Products (ASTM Practice [D5854](#))
- MPMS* Chapter 8.4 Practice for Manual Sampling and Handling of Fuels for Volatility Measurement (ASTM Practice [D5842](#))

¹ This practice is under the jurisdiction of ASTM Committee [D02](#) on Petroleum Products and Lubricants and the API Committee on Petroleum Measurement, and is the direct responsibility of Subcommittee [D02.02/COMQ](#), the joint ASTM-API Committee on Static Petroleum Measurement.

Current edition approved June 1, 2005. Published January 2006. Originally approved in 1982. Last previous edition approved in 2000 as D4177–95(2000). DOI: 10.1520/D4177-95R05.

² For referenced ASTM standards, visit the ASTM website, www.astm.org, or contact ASTM Customer Service at service@astm.org. For *Annual Book of ASTM Standards* volume information, refer to the standard's Document Summary page on the ASTM website.

³ Withdrawn.

⁴ Available from American Petroleum Institute, 1220 L St., NW, Washington, DC 20005.

MPMS Chapter 10.9 Test Method for Water in Crude Oils by Coulometric Karl Fischer Titration (ASTM Test Method **D4928**)

2.3 *Gas Processors Association Standard*.⁵

GPA 2166 Obtaining Natural Gas Samples for Analysis by Gas Chromatography

2.4 *Institute of Petroleum Standard*.⁶

IP Petroleum Measurement Manual, Part IV, Sampling Section 2, Guide to Automatic Sampling of Liquids from Pipelines, Appendix B, 34th Ed

2.5 *Government Standard*.⁷

CFR 29, Part 1910.1000 Toxic and Hazardous Substances

3. Terminology

3.1 *Definitions of Terms Specific to This Standard:*

3.1.1 *automatic sampler, n*—a device used to extract a representative sample from the liquid flowing in a pipe.

3.1.1.1 *Discussion*—The automatic sampler usually consists of a probe, a sample extractor, an associated controller, a flow measuring device, and a sample receiver.

3.1.2 *automatic sampling system, n*—a system consisting of stream conditioning, an automatic sampler, and sample mixing and handling.

3.1.3 *dissolved water, n*—water in solution in petroleum and petroleum products.

3.1.4 *emulsion, n*—a water in oil mixture, which does not readily separate.

3.1.5 *entrained water, n*—water suspended in the oil.

3.1.5.1 *Discussion*—Entrained water includes emulsions but does not include dissolved water.

3.1.6 *flow proportional sample, n*—flow taken such that the rate is proportional throughout the sampling period to the flow rate of liquid in the pipe.

3.1.7 *free water, n*—water that exists as a separate phase.

3.1.8 *grab, n*—the volume of sample extracted from a pipeline by a single actuation of the sample extractor.

3.1.9 *homogeneous, adj*—when liquid composition is the same at all points in the container, tank, or pipeline cross section.

3.1.10 *isokinetic sampling, n*—sampling in such a manner that the linear velocity through the opening of the sample probe is equal to the linear velocity in the pipeline at the sampling location and is in the same direction as the bulk of the liquid approaching the sampling probe.

3.1.11 *Newtonian fluid, n*—a liquid whose viscosity is unaffected by the order of magnitude or agitation to which it may be subjected as long as the temperature is constant.

3.1.12 *power mixer, n*—a device which uses an external source of power to achieve stream conditioning.

3.1.13 *primary sample receiver/container, n*—a vessel into which all samples are initially collected.

3.1.14 *probe, n*—the portion of the automatic sampler that extends into the pipe and directs a portion of the fluid to the sample extractor.

3.1.15 *profile testing, n*—a procedure for simultaneously sampling at several points across the diameter of a pipe to identify the extent of stratification.

3.1.16 *representative sample, n*—a portion extracted from a total volume that contains the constituents in the same proportions as are present in the total volume.

3.1.17 *sample, n*—a portion extracted from a total volume that may or may not contain the constituents in the same proportions as are present in that total volume.

3.1.18 *sample controller, n*—a device which governs the operation of the sample extractor.

3.1.19 *sample extractor, n*—a device which removes a sample (grab) from a pipeline, sample loop, or tank.

3.1.20 *sample handling and mixing, n*—the conditioning, transferring and transporting of a sample.

3.1.21 *sample loop (fast loop or slip stream), n*—a low volume bypass diverted from the main pipeline.

3.1.22 *sampling, n*—all the steps required to obtain a sample that is representative of the contents of any pipe, tank, or other vessel and to place that sample into a container from which a representative test specimen can be taken for analysis.

3.1.23 *sampling system proving, n*—a procedure used to validate an automatic sampling system.

3.1.24 *sediment and water (S&W), n*—material which coexists with, but is foreign to, a petroleum liquid.

3.1.24.1 *Discussion*—S&W may include dissolved water, free water and sediment, and emulsified and entrained water and sediment.

3.1.25 *static mixer, n*—a device which utilizes the kinetic energy of the flowing fluid to achieve stream conditioning.

3.1.26 *stream condition, n*—the distribution and dispersion of the pipeline contents, upstream of the sampling location.

3.1.27 *stream conditioning, n*—the mixing of a flowing stream so that a representative sample can be extracted.

3.1.28 *time proportional sample, n*—a sample composed of equal volume grabs taken from a pipeline at uniform time intervals during the entire transfer.

3.1.29 *worst case conditions, n*—the operating conditions for the sampler that represent the most uneven and unstable concentration profile at the sampling location.

4. Significance and Use

4.1 Representative samples of petroleum and petroleum products are required for the determination of chemical and physical properties, which are used to establish standard volumes, prices, and compliance with commercial and regulatory specifications.

5. Representative Sampling Criteria

5.1 The following criteria must be satisfied to obtain a representative sample from a flowing stream.

5.1.1 For nonhomogeneous mixtures of oil and water, free and entrained water must be uniformly dispersed at the sample point.

⁵ Available from Gas Processors Association (GPA), 6526 E. 60th St., Tulsa, OK 74145.

⁶ Available from Energy Institute, 61 New Cavendish St., London, WIG 7AR, U.K.

⁷ Available from U.S. Government Printing Office, Superintendent of Documents, 732 N. Capitol St., NW, Mail Stop: SDE, Washington, DC 20401.

5.1.2 Grabs must be extracted and collected in a flow proportional manner that provides a representative sample of the entire parcel volume.

5.1.3 Grabs must be a consistent volume.

5.1.4 The sample must be maintained in the sample receiver without altering the sample composition. Venting of hydrocarbon vapors during receiver filling and storage must be minimized. Samples must be mixed and handled to ensure a representative test specimen is delivered into the analytical apparatus.

6. Automatic Sampling Systems

6.1 An automatic sampling system consists of stream conditioning upstream of the sampling location, a device to physically extract a grab from the flowing stream, a flow measurement device for flow proportioning, a means to control the total volume of sample extracted, a sample receiver to collect and store the grabs and, depending on the system, a sample receiver/mixing system. Unique properties of the petroleum or petroleum product(s) being sampled may require the individual components or the entire system be insulated or heated, or both. Appendix X1 references many of the design considerations that should be taken into account.

6.2 Grabs must be taken in proportion to flow. However, if the flow rate, during the total parcel delivery (week, month, etc.) varies less than ±10 % from the average flow rate, a representative sample may be obtained by the time proportional control of the grabs.

6.3 There are two types of automatic sampling systems (see Fig. 1). Both systems can produce representative samples if properly designed and operated. One system locates the extracting device directly in the main line, whereas the other system locates the extracting device in a sample loop.

6.4 In a sample loop type system, a probe is located in the main pipeline and directs a portion of the fluid flow into the sample loop. This probe may be a 90° elbow or a 45° level facing upstream (see 10.2). The average flow velocity through the sample loop shall be near the maximum average velocity expected in the main pipeline, but not less than 2.5 m/s (8 ft/s).

6.5 The controller which operates the sample extractor in the sample loop receives its flow proportional signal from the flow meter(s) in the main line. For sample loop installations, a flow indicator must also be installed in the sample loop.

6.6 If circulation in the sample loop stops and sampling continues, a non-representative sample will result. A low-flow alarm should be installed to alert the operator of a loss of flow. In no case shall a filter be installed in a sample loop, upstream of the sample extractor, as it may alter the representativeness of the sample.

7. Sampling Frequency

7.1 Guidelines for sampling frequency can be given in terms of “grab per lineal distance of pipeline volume.” For marine and pipeline service this minimum guideline can be related to barrels per grab using the following equation:

$$BBL/grab = 0.0001233 \times D^2 \text{ or } 0.079548 \times d^2 \quad (1)$$

where:

D = nominal pipe diameter, mm and

d = nominal pipe diameter, in.

7.2 This formula equates to one grab for every 25 lineal metres (approximately 80 ft) of pipeline volume.

7.3 Sampling frequency should be based on maximizing grabs for the available receiver size. Typically, Lease Automatic Custody Transfer (LACT) or Automatic Custody Transfer (ACT) units are paced at one grab per one to ten barrels.

7.4 The optimum sampling frequency is the maximum number of grabs which may be obtained from any parcel operating within the grab frequency and grab volume limitations of the equipment. The completed sample should be of sufficient volume to mix and properly analyze while not over filling the sample receiver.

8. Stream Conditioning

8.1 The sampler probe must be located at a point in the pipe where the flowing stream is properly conditioned. This conditioning may be accomplished with adequate flow velocity through the piping system or mixing elements may be added to

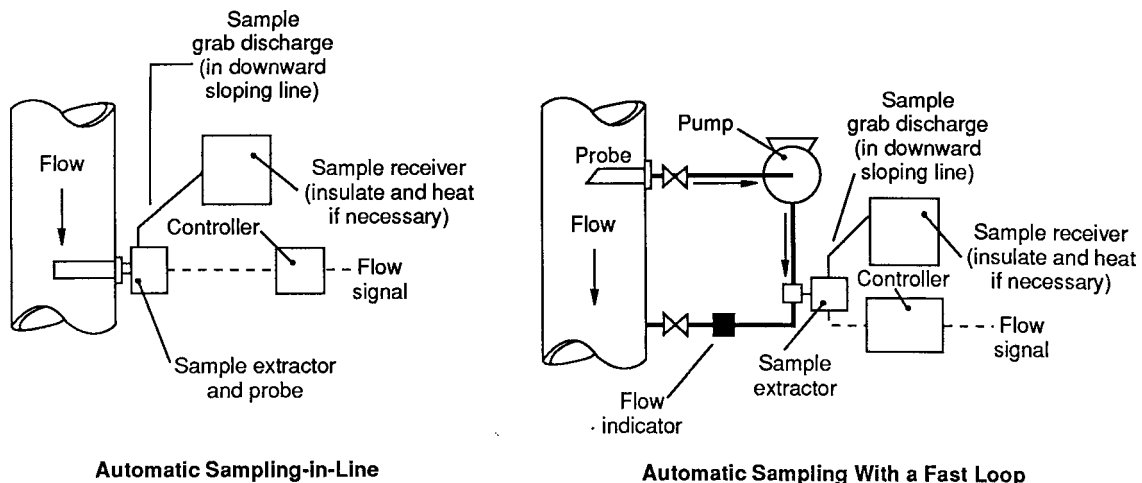

NOTE—ARROW does not indicate piping orientation.

FIG. 1 Typical Automatic Sampling Systems

supplement mixing provided by the basic piping. Petroleum that contains free or entrained sediment and water (S&W) requires adequate mixing energy to create a homogeneous mixture at the sample point.

8.2 Petroleum products are generally homogeneous and usually require no special stream conditioning. Exceptions to this may occur if free water is present or if a product is exiting a blending system.

8.3 *Velocities and Mixing Elements:*

8.3.1 Fig. 2, based on tests, provides a guideline for minimum velocities versus mixing elements for pipes 50 mm (2 in.) in diameter and larger. Stream conditioning can be accomplished with pressure reducing valves, metering manifolds, lengths of reduced diameter piping, or piping elements (valves, elbows, tees, piping, or expansion loops).

8.3.2 Where the flow velocity at the automatic sampler probe location falls below the minimum levels detailed in Fig. 2, additional means will be required to provide adequate stream conditioning such as power mixers or static mixers. The effect of viscosity, density, water content, as well as the relative position of the mixing element(s) and sample probe should also be considered.

8.3.3 Specific calculation procedures for estimating the acceptability of a proposed or existing sampling location are detailed in Annex A2.

8.3.4 Again it should be remembered that petroleum products are assumed to be homogeneous at the point of sampling and require no additional stream conditioning unless specifically sampling for water content, or where the sampler is downstream of a blending manifold.

9. Special Considerations for Marine Applications

9.1 When pumping from a shore tank or from a vessel, a significant amount of free water may be transferred during a short period of time (see Appendix X2). This may occur when the pumping rate is low and the oil/water mixture is stratified. The stream conditioning may not be adequate to provide a representative sample. To help minimize this condition, a tank that does not contain free water should be utilized first. Tanks containing free water can be discharged when the pumping rate is normal.

9.2 If the sampler is located some distance from the point of load/discharge, operating procedures should account for the line fill between those two points.

10. Probes

10.1 *Probe Location and Installation:*

10.1.1 The recommended sampling area is approximately the center one-third of the pipeline cross-section area as shown in Fig. 3.

10.1.2 The probe opening must face upstream and the external body of the probe should be marked with the direction of flow to verify that the probe is installed correctly.

10.1.3 The probe must be located in a zone where sufficient mixing results in adequate stream conditioning. This zone is generally from 3 to 10 diameters downstream of piping elements, 0.5 to 4 diameters from static mixers, and 3 to 10 diameters from power mixers. When static or power mixers are used, the manufacturer of the device should be consulted for the probe's optimum location.

10.1.4 The line from the outlet of the extractor to the sample receiver must continuously slope downward from the extractor to the receiver and contain no dead space.

10.1.5 The preferred installation of a combined probe-extractor is in the horizontal plane.

10.1.6 If a vertical piping loop is used for stream conditioning, locate the probe in the downflow section of the loop to obtain the benefit of the additional stream conditioning provided by the three 90° elbows. Locate the probe a minimum of three pipe diameters downstream of the top 90° elbow and not closer than one-half pipe diameter upstream of the final exiting elbow (see Fig. 4).

10.1.7 According to tests sponsored by the American Petroleum Institute (API), locating a sample probe downstream of a single 90° bend is not recommended because of inadequate stream conditioning.

10.2 *Probe Design:*

10.2.1 The mechanical design of the probe should be compatible with the operating conditions of the pipeline and the fluid being sampled. There are three basic designs shown in Fig. 5. Probe openings should be in the center third of the cross sectional area of the pipe.

Mixing Element	Piping	Minimum Pipeline Velocity, meters per second								
		0	.305	.61	.91	1.22	1.52	1.83	2.13	2.44
Power mixing	Horizontal or vertical	Adequate at any velocity								
		Stratified	Not Predictable	Adequately dispersed						
Static mixing	Vertical	Stratified		Not predictable		Adequately dispersed				
Static mixing	Horizontal	Stratified		Not predictable		Adequately dispersed				
Piping elements	Vertical	Stratified		Not predictable		Adequately dispersed				
Piping elements	Horizontal	Stratified			Not predictable			Adequately dispersed		
None	Horizontal or vertical	Stratified or not predictable								
		0	1	2	3	4	5	6	7	8
		Minimum Pipeline Velocity, feet per second								

FIG. 2 General Guidelines for Minimum Velocities Versus Mixing Elements

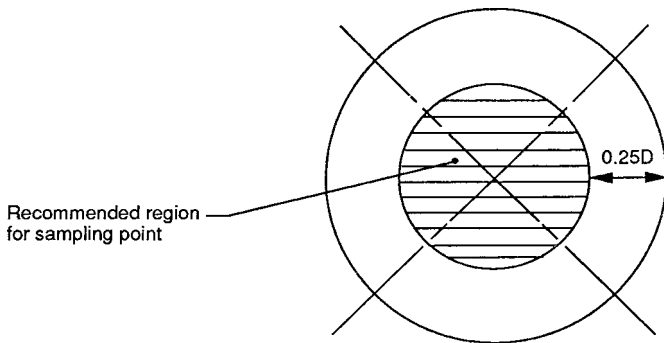

FIG. 3 Recommended Sampling Area

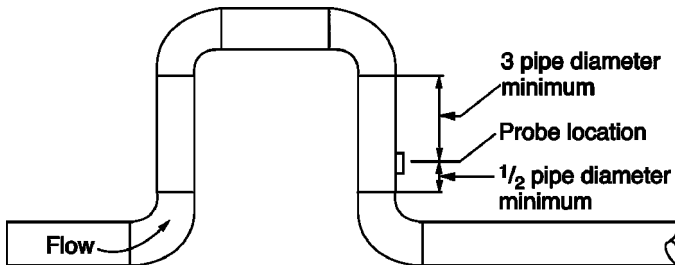

FIG. 4 General Vertical Piping Loop Configuration

10.2.2 Probe designs commonly used are described as follows:

10.2.2.1 A closed end probe equipped with an open orifice (see Fig. 5A).

10.2.2.2 A short-radius elbow or pipe bend facing upstream. The end of the probe should be chamfered on the inside diameter to give a sharp entrance (see Fig. 5B).

10.2.2.3 A tube cut at a 45° angle with the angle facing upstream (see Fig. 5C).

11. Automatic Sampling Components

11.1 *Extractor*—An automatic sample extractor is a device that extracts a sample (grab) from the flowing medium. The extractor may or may not be an integral part of the probe. The sample extractor should extract a consistent volume that is repeatable within $\pm 5\%$ over the range of operating conditions and sampling rates.

11.2 *Controller*—A sample controller is a device which governs the operation of the sample extractor. The sample controller should permit the selection of the sampling frequency.

12. Sampler Pacing

12.1 *Custody Transfer Meters*—Custody transfer meters should be used to pace the sampler where available. When flow is measured by multiple meters, the sampler should be paced by the combined total flow signal. Alternatively, a separate sampler may be installed in each meter run. The sample from each meter run must be considered a part of the total sample and in the same proportion as that meter's volume is to the total volume.

12.2 *Special Flow Meters*—When custody transfer is by tank measurements, a flow signal must be provided to the sample controller. This signal may be provided by an add-on

flow metering device. These devices should have an accuracy of $\pm 10\%$ or better, over the total volume of the parcel.

12.3 *Time Proportional Sampling*—An automatic sampler should preferably operate in proportion to flow. However, sampling in a time proportional mode is acceptable if the flow rate variation is less than $\pm 10\%$ of the average rate over the entire parcel.

13. Primary Sample Receivers

13.1 A sample receiver/container is required to hold and maintain the composition of the sample in liquid form. This includes both stationary and portable receivers, either of which may be of variable or fixed volume design. If the loss of vapors will significantly affect the analysis of the sample, a variable volume type receiver should be considered. Materials of construction should be compatible with the petroleum or petroleum product sampled.

13.2 *Stationary Receivers:*

13.2.1 *General Design Features*—These features may not be applicable to some types of receivers, that is, variable volume receivers.

13.2.1.1 Receiver design must allow for preparation of a homogeneous mixture of the sample.

13.2.1.2 The bottom of the receiver must be continuously sloped downward toward the drain to facilitate complete liquid withdrawal. There should be no internal pockets or dead spots.

13.2.1.3 Internal surfaces of the receiver should be designed to minimize corrosion, encrustation, and clingage.

13.2.1.4 A means should be provided to monitor filling of the receiver. If a sight glass is used, it must be easy to clean and not be a water trap.

13.2.1.5 A relief valve should be provided and set at a pressure that does not exceed the design pressure of the receiver.

13.2.1.6 A means to break vacuum should be provided to permit sample withdrawal from the receiver.

13.2.1.7 A pressure gauge should be provided.

13.2.1.8 Receivers should be sheltered from adverse ambient conditions when in use.

13.2.1.9 Receivers may need to be heat traced or insulated, or both, when high pour point or high viscosity petroleum or petroleum products are sampled. Alternatively, they may be housed in heated and insulated housing. Exercise caution to ensure added heating does not affect the sample.

13.2.1.10 Use of multiple sample receivers should be considered to allow flexibility in sampling sequential parcels and line displacements. Exercise care in the piping design to prevent contamination between samples of different parcels. See Fig. 6.

13.2.1.11 Receivers should have an inspection cover or closure of sufficient size to facilitate easy inspection and cleaning.

13.2.1.12 Facilities for security sealing should be provided.

13.2.1.13 The system must be capable of completely draining the receiver, mixing pump, and associated piping.

13.2.1.14 The circulating system shall not contain any dead legs.

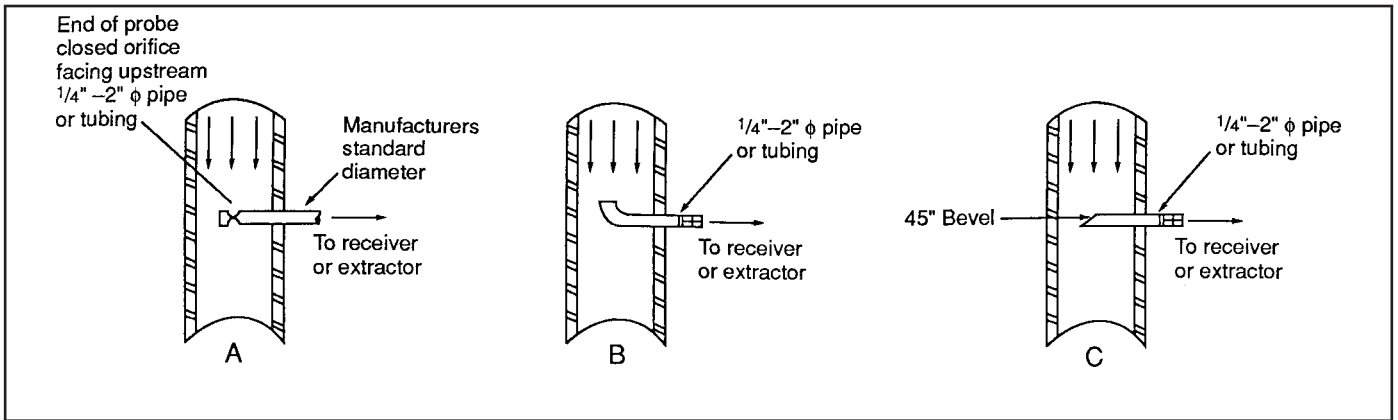
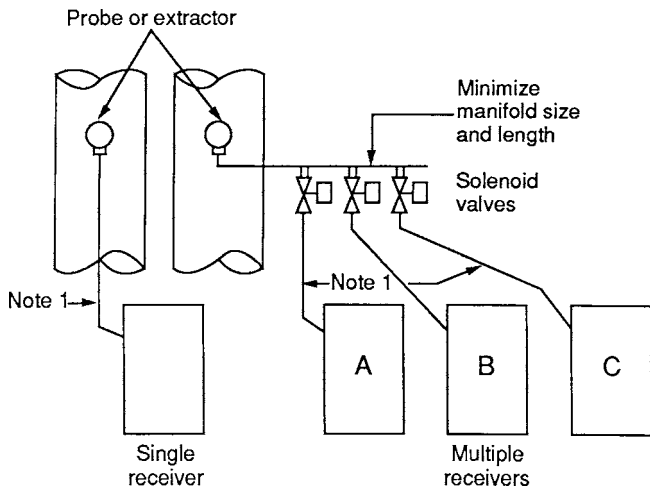

FIG. 5 Probe Designs



NOTE—6.4 or 9.5 mm (1/4 or 3/8 in.) tubing, as short as possible and sloping continuously toward the sample receiver, should be used. 9.5 mm (3/8 in.) tubing should be used where long sampling lines cannot be avoided or in crude oil service. Heat trace and insulate these lines when necessary.

FIG. 6 Receiver(s) Installation

13.3 *Portable Receivers*—In addition to considerations outlined in 13.2, portable receivers may include the following additional features:

- 13.3.1 Light weight,
- 13.3.2 Quick release connections for easy connection/disconnect to the probe/extractor and the laboratory mixer (see Fig. 7), and
- 13.3.3 Carrying handles.

13.4 *Receiver Size*—The receiver should be sized to match its intended use and operating conditions. The size of the receiver is determined by the total volume of sample required, the number of grabs required, the volume of each grab and, transportability of the receiver if portable. Typical sample receiver sizes are shown in Table 1.

14. Sample Mixing and Handling

14.1 Sample in the receiver must be properly mixed to ensure a homogenous sample. Transfer of samples from the receiver to another container or the analytical glassware in

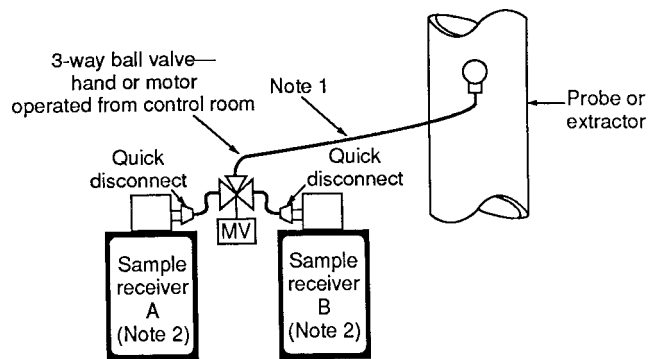

Installation Showing Portable Receivers

NOTE 1—6.4 or 9.5 mm (3/8 in.) tubing, as short as possible and sloping continuously toward the sample receiver should be used. Three-eighths inch tubing should be considered where long sampling lines cannot be avoided or the crude oil is viscous. Heat trace and insulate these lines when necessary.

NOTE 2—Sample should flow into a connection at the top of the container.

NOTE 3—In warm climates, a sun shield should be provided to avoid excessive temperature changes in sample receivers.

NOTE 4—In cold climates, consider placing sample receivers in a heated housing or heat trace and insulate the receivers and sample lines.

FIG. 7 Portable Receiver(s) Installation

TABLE 1 Typical Receiver Sizes

Lease automatic custody transfer	10–60 L (3–15 gal)
Pipelines (crude petroleum)	20–60 L (5–15 gal)
Pipelines (products)	4–20 L (1–5 gal)
Portable sampler	1–20 L (1 qt–5 gal)
Tanker loading/unloading	20–75 L (5–20 gal)

which they will be analyzed requires special care to maintain their representative nature. See Practice D5854 (API MPMS Chapter 8.3) for detailed procedures.

15. Portable Samplers

15.1 A typical application of a portable sampling system is on board a marine vessel. There are also occasional applications on shore. The same criteria for representative sampling applies to both portable and stationary sampling systems. Exercise caution when using portable samplers on marine

vessels due to the difficulty in verifying stream conditioning during actual operations. An example of a marine application is shown in Fig. 8.

15.2 *Design Features*—Special features and installation requirements for a portable sampler are:

15.2.1 A spool assembly fitted with a sample probe/extractor and flow sensor is inserted between the ship's manifold and each loading/unloading arm or hose. If the grab size of each sampler is equal, a common receiver can be used.

15.2.2 A controller is required for each extractor. The controller must be able to record total number of grabs and total volume.

15.2.3 Piping arrangement at the ship's manifold will often distort the flow profile. The flow sensor, when operated under the piping and flow conditions at the ship's manifold, must meet the accuracy criteria in 12.2.

15.2.4 Stream conditioning is accomplished by velocity of the fluid and the piping elements ahead of the probe. The number of hoses, arms, and lines in service at any one time may need to be limited to maintain sufficiently high velocity.

15.2.5 The controller may be placed on the ship's deck, which is usually classified as a hazardous zoned area. If the controller is electronic, it should meet the requirements of the hazardous area.

15.2.6 Air supply must meet the requirements of the equipment.

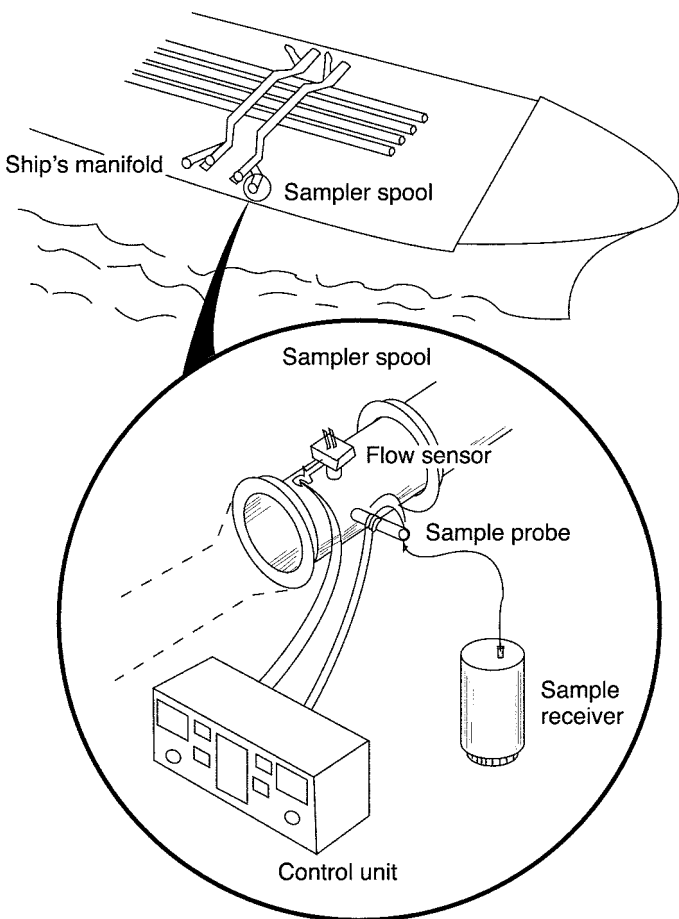

FIG. 8 Typical Portable Marine Installation

15.2.7 For high pour or viscous fluids, particularly in cold climates, the line from the extractor to the receiver may require a thermally insulated high pressure hose or tubing. The receiver should be placed as close to the extractor as possible to minimize the hose length. The hose or tubing should have an internal diameter of 9.5 mm ($\frac{3}{8}$ in.) or more and slope continuously downward from the extractor to the receiver. The line from the extractor to the receiver may have to be heat traced.

15.2.8 Filling of receivers should be monitored to ensure that each sampler is operating properly. Frequent visual inspection, level indicators, and weighing have proven to be acceptable monitoring methods.

15.2.9 The portable sampler is used intermittently; therefore the sample probe, extractor, and flow sensor should be cleaned after every use to prevent plugging.

15.2.10 All components and installation must meet applicable regulations, such as those of the U.S. Coast Guard.

15.3 *Operating Considerations*—The portable sampler operator must maintain operating conditions which provide adequate mixing and produce a representative sample. Performance criteria is given in Annex A5. To meet the criteria requires cooperation of the vessel crew and shore personnel. Special operating requirements are:

15.3.1 The portable sampler operator should keep the flow rate at each flow sensing device within its design range by limiting the number of loading lines or hoses in service during periods of low flow rates, for example, start-up, topping off, stripping, etc.

15.3.2 For discharge operations, the vessel compartment discharge sequence must be controlled so that the amount of free water being discharged during the start-up operation is less than 10 % of the total amount of water in the cargo.

15.3.3 For loadings, a shore tank with no free water is preferred for the initial pumping. Water drawing the tank or pumping a small portion of the tank to another shore tank prior to the opening tank gauge, or both, are suggested.

16. Acceptance Tests

16.1 Testing is recommended to confirm that a sampling system is performing accurately. Annex A3 outlines methods for testing samplers that are used for the collection of S&W or free water samples. The test methods fall in two general categories; Total System Testing and Component Testing.

16.2 *Total System Testing*—This test method is a volume balance test where tests are conducted for known amounts of water. It is designed to test the total system including the laboratory handling and mixing of sample. Two procedures are outlined. One involves only the sampler under test, the other utilizes an additional sampler to measure the baseline water.

16.3 *Component Testing*—This test method involves testing individually the components that comprise a sampling system. Where applicable, some of the component tests may be conducted prior to installation of the total system. Components to be tested include:

- 16.3.1 Probe/extractor,
- 16.3.2 Profile (for stream conditioning),
- 16.3.3 Special flow meter, and
- 16.3.4 Primary sample receiver and mixer.

16.3.5 If a system design has been proven by testing, subsequent systems of the same design (for example, LACT units), including piping configuration and operated under the same or less critical conditions (that is, higher flow rate, higher viscosity, lower water content, etc.) need not be tested. Once a system or system design has been proven, the following checks can be used to confirm system reliability:

Component	Check
Stream conditioning	Flow rate or pressure drop if equipped with power or static mixer. Profile test for systems with only piping elements.
Pacing device	Compare recorded batch volume to known volume. Compare actual sample volume to expected volume.
Extractor	Compare actual sample volume to expected volume. Compare actual grab size to expected grab size.

16.3.6 Portable sampling systems can be tested by the component testing method except for proper stream conditioning. To compensate for this, the performance test for each operation has been designed to evaluate the operation of the sampler. This is shown in [Annex A5](#).

16.4 *Requirements for Acceptability*—Testing by either the component or total system method requires that two out of three consecutive sets of test data repeat within the limits shown in [Annex A3](#).

17. Operational Performance Checks/Reports

17.1 Monitoring of sampler performance is a necessary part of every sampling operation. Monitoring is required to make

sure that the sample extractor is extracting a uniform grab in a flow proportional manner. This is normally accomplished by assessing the sample volume collected to ensure that it meets expectations for the equipment and transfer volume involved.

17.2 Several procedures may be used to accomplish this requirement, that is, sight glasses, gages, or weigh cells. Selection of a procedure should be based on (1) volume of transfer, (2) type of installation, (3) time interval of transfer, (4) whether the sampling facility is manned, (5) receiver type, (6) purpose of the sample, and (7) equipment used.

17.3 For LACT and ACT units, monitoring may consist of comparison between sample volume collected and expected sample volume. For very large transfers including marine transferee, more information may be desired as outlined in [Annex A4](#) and [Annex A5](#).

18. Keywords

18.1 acceptance tests; automatic petroleum sampling; controllers; extractor; intermediate sampling receiver; isokinetic sampling; mixing elements; portable samplers; primary sample receiver; probe; representative sampling; representative sampling criteria; sample loop; sample mixing; sampling handling; stream conditioning

ANNEXES

(Mandatory Information)

A1. PRECAUTIONARY INFORMATION

A1.1 Physical Characteristics and Fire Considerations

A1.1.1 Personnel involved in the handling of petroleum-related substances (and other chemical materials) should be familiar with their physical and chemical characteristics, including potential for fire, explosion, and reactivity, and appropriate emergency procedures. These procedures should comply with the individual company's safe operating practices and local, state, and federal regulations, including those covering the use of proper protective clothing and equipment. Personnel should be alert to avoid potential sources of ignition and should keep the materials' containers closed when not in use.

A1.1.2 API Publication 2217 and Publication 2026⁴ and any applicable regulations should be consulted when sampling requires entry to confined spaces.

A1.1.3 INFORMATION REGARDING PARTICULAR MATERIALS AND CONDITIONS SHOULD BE OBTAINED FROM THE EMPLOYER, THE MANUFACTURER OR SUPPLIER OF THAT MATERIAL OR THE MATERIAL SAFETY DATA SHEET.

A1.2 Safety and Health Consideration

A1.2.1 *General*—Potential health effects can result from exposure to any chemical and are dependent on the toxicity of the chemical, concentration, and length of the exposure.

Everyone should minimize his or her exposure to work place chemicals. The following general precautions are suggested:

- (1) Minimize skin and eye contact and breathing of vapors.
- (2) Keep chemicals away from the mouth; they can be harmful or fatal if swallowed or aspirated.
- (3) Keep containers closed when not in use.
- (4) Keep work areas as clean as possible and well ventilated.
- (5) Clean spills promptly and in accordance with pertinent safety, health, and environmental regulations.
- (6) Observe established exposure limits and use proper protective clothing and equipment.

NOTE A1.1—Information on exposure limits can be found by consulting the most recent editions of the Occupational Safety and Health Standards, 29 Code of Federal Regulations Part 1910.1000 and following and the ACGIH publication "Threshold Limit Values for Chemical Substances and Physical Agents in the Work Environment."⁸

A1.2.1.1 INFORMATION CONCERNING SAFETY AND HEALTH RISKS AND PROPER PRECAUTIONS WITH

⁸ Available from American Conference of Government Industrial Hygienists, (ACGIH), Bldg. D-7, 6500 Glenway Ave., Cincinnati, OH 45211-4438.

RESPECT TO PARTICULAR MATERIALS AND CONDITIONS SHOULD BE OBTAINED FROM THE EMPLOYER,

THE MANUFACTURER OR THE MATERIAL SAFETY DATA SHEET.

A2. THEORETICAL CALCULATIONS FOR SELECTING THE SAMPLER PROBE LOCATION

A2.1 Introduction

A2.1.1 This annex describes calculation procedures for estimating the dispersion of water-in-oil at a sampling location. These procedures have a very simple theoretical base with many of the equations not being strictly applicable; therefore, they should be used with extreme caution in any practical application. A conservative approach is strongly recommended when estimating the acceptable limits for adequate dispersion (steam conditioning).

NOTE A2.1—From IP Petroleum Measurement Manual, Part IV Sampling:

A2.1.2 The equations contained in this annex have been shown to be valid for a large number of field data. The range of the field data covered the following correlating parameters:

Relative density	0.8927–0.8550 (27°–34° API)
Pipe diameter	40 cm–130 cm (16 in.–52 in.)
Viscosity	6–25 cSt at 40°C
Flowing velocity	>0–3.7 m/s (>0–12 ft/s)
Water concentration	<5 %

NOTE A2.2—Use caution when extrapolating outside of these ranges.

A2.1.3 When evaluating if dispersion is adequate or not in a given system, using the worst case conditions is recommended.

A2.1.4 When calculating the dispersion rate *E* in A2.4, it should be noted that dispersion energies of different piping elements are not additive in regard to dispersion, that is, when a series of elements is present, the element that should be considered is the one that dissipates energy the most.

PUMP	ΔP (bar)												
ORIFICE	$\gamma = d/D =$	0.9		0.8		0.7		0.6		0.5		0.4	
ENLARGEMENT	$\gamma = d/D =$	x		x		x		x		x		x	
THROTTLING VALVE	ΔP (bar)												
GLOBE VALVE													
SWING CHECK OR ANGLE VALVE													
CIRCULAR MITRE BEND	θ (deg)												
		45		60		90							
CONTRACTION	$\gamma = d/D$	0.8	0.7	0.5	0.1								
BENDS (5-OFF)	r/D	x	x	x	x								
BENDS (4-OFF)	r/D		10	4	1								
BENDS (3-OFF)	r/D		x	x	x								
BENDS (2-OFF)	r/D			10	1								
BENDS (1-OFF)	r/D			x	x								
STRAIGHT PIPE													
GATE VALVE													
RESISTANCE COEFFICIENT (K)		0.2	0.5	1.0	2.0	4.0	10.0	20.0	40.0	100.0	200.0	400.0	1000.0
CHARACTERISTIC (β)		1.0	2.5	5.0	10.0	20.0	50.0	100.0	200.0	500.0	1000.0	2000.0	5000.0
PARAMETER OF MIXING ELEMENT													

NOTE 1—The table has been compiled assuming the same pipeline diameter downstream of any device. If the downstream diameter of any two devices is not identical, comparisons using Fig. A2.1 cannot be performed.

NOTE 2—It is not intended that Fig. A2.1 be used to ascertain β or K values but only to provide a comparison of the likely mixing effects of devices.

NOTE 3—For centrifugal pumps and throttling valves, the dissipation energies, which are defined without the use of β values (see Table A2.4), the comparison has been done using an assumed β equal to E/E_o and the following typical values— $D = 0.4$ m; $\nu = 16$ cSt; $\rho = 900$ kg/m³; $V = 5.6$ m/s.

FIG. A2.1 Comparison of Mixing Devices

A2.1.5 As an aid in determining the element most likely to provide adequate dispersion, Fig. A2.1 has been developed. When using Fig. A2.1, it is important to consider it as a guide only and that particular attention should be paid to the notes. Fig. A2.1 does not preclude the need for a more detailed analysis of these elements, within a given system, shown by the table to be the most effective.

A2.2 *Symbols*—The symbols used in Annex A2 are presented in Table A2.1.

A2.3 Dispersion Factors

A2.3.1 As a measure of dispersion, the ratio of water concentration at the top of a horizontal pipe C_1 to that at the bottom C_2 is used. A C_1/C_2 ratio of 0.9 to 1.0 indicates very good dispersion while a ratio of 0.4 or smaller indicates poor dispersion with a high potential for water stratification. Calculations giving ratios less than 0.7 should not be considered reliable as coalescence of water droplets invalidates the prediction technique.

A2.3.2 The degree of dispersion in horizontal pipes can be estimated by:

$$\frac{C_1}{C_2} = \exp\left(\frac{-W}{\varepsilon/D}\right) \quad (\text{A2.1})$$

where:

- C_1/C_2 = the ratio of water concentration at the top (C_1) to that at the bottom (C_2),
- W = the settling rate of the water droplets, and
- ε/D = the turbulence characteristic, where ε is the eddy diffusivity and D the pipe diameter.

A2.3.3 An alternative measure of dispersion, G , can be defined in Eq A2.2. Table A2.2 presents the relationship of C_1/C_2 with G .

TABLE A2.1 Symbols Used in Annex A2

- NOTE 1—1 Pa = 10^{-5} bar
- NOTE 2—1 $\text{m}^2/\text{s} = 10^6$ cSt = 10^6 mm^2/s
- NOTE 3—1 N/m = 10^3 dyn/cm

Symbol	Term	Units
C	water concentration (water/oil ratio)	dimensionless
D	pipe diameter	m
d	droplet diameter	m
E	rate of energy dissipation	W/kg
E_o	energy dissipation in straight pipe	W/kg
E_r	required energy dissipation	W/kg
G	parameter, defined in A2.3.3	dimensionless
K	resistance coefficient	dimensionless
n	number of bends	dimensionless
ΔP	pressure drop	Pa (Note 1)
Q	volumetric flow rate	m^3/s
r	bend radius	m
V	flow velocity	m/s
V_j	flow nozzle exit velocity	m/s
W	settling rate of water droplets	m/s
ΔX	dissipation distance	m
β	parameter, defined in A2.4.3	dimensionless
γ	ratio between small and large diameters	dimensionless
ε	eddy diffusivity	m^2/s
θ	turn angle	degrees
ν	kinematic viscosity	m^2/s (Note 2)
σ	surface tension	N/m (Note 3)
ρ	crude oil density	kg/m^3
ρ_d	water density at line temperature	kg/m^3
ϕ	flow nozzle diameter	m

TABLE A2.2 Dispersion Factors

G	C_1/C_2	C_2/C_1
10	0.90	1.11
8	0.88	1.14
6	0.85	1.18
4	0.78	1.28
3	0.71	1.41
2	0.61	1.64
1.5	0.51	1.96
1	0.37	2.70

$$G = \frac{\varepsilon/D}{W} \quad (\text{A2.2})$$

A2.3.4 It is important to note that the uncertainty of the calculations is such that errors in G of more than 20 % may result at low values of G . For this reason, it is recommended that no reliance be placed upon calculated G values of less than 3 and that additional energy dissipation calculated G value.

A2.4 Determination of Energy Dissipation

A2.4.1 Two different techniques are given for determining the rate of energy dissipation.

A2.4.2 Method A uses the relationship in Eq A2.3.

$$E = \frac{\Delta PV}{\Delta X \rho} \quad (\text{A2.3})$$

where:

- ΔP = the pressure drop across the piping element,
- V = the flow rate at the pipe section in which energy is dissipated, and
- ΔX = a characteristic length which represents the distance in which energy has been dissipated.

In most cases ΔX is not known with any confidence. Wherever possible, the value to be used should be supported by experimental data.

NOTE A2.3—If ΔX is not known, a substitute value of $\Delta X = 10D$ may be used as a very rough approximation for devices of low mixing efficiency such as those in Table A2.3. For specially designed high efficiency static mixers the value ΔX will be small and should be obtained from the designer.

NOTE A2.4—If ΔP is not known, calculate it from Eq A2.4.

TABLE A2.3 Suggested Resistance Coefficients, K

NOTE— γ is the small diameter/large diameter and K is based on the velocity in the smaller pipe.

Contraction	$K = 0.5 (1 - \gamma^2)$	$(0 \leq K \leq 0.5)$
Enlargement	$K = \frac{(1 - \gamma^2)^2}{\gamma^4}$	$(0 \leq K \leq 0.5)$
Orifice	$K = 2.8 (1 - \gamma^2) \left[\left(\frac{1}{\gamma} \right)^4 - 1 \right]$	
Circular mitre bends	$K = 1.2 (1 - \cos \theta)$ where θ = turn angle	$(0 \leq K \leq 1.2)$
Swing check valve	$K = 2$	
Angle valve	$K = 2$	
Globe valve	$K = 6$	
Gate valve	$K = 0.15$	

$$\Delta P = \frac{K\rho V^2}{2} \quad (\text{A2.4})$$

where:

K = the resistance coefficient of the piping element under consideration.

Suggested values of K for different piping elements are given in [Table A2.3](#).

A2.4.3 Method B uses the relationship $E = \beta E_0$, where β is a characteristic parameter of a mixing element and E_0 is the rate of energy dissipation in a straight pipe. E_0 is calculated from Eq A2.5.

$$E_0 = 0.005\nu^{0.25}D^{-1.25}V^{2.75} \quad (\text{A2.5})$$

where: ν is given in mm²/s (cSt).

A2.4.4 Suggested values of β and tentative relationships for E (other than $E = \beta E_0$) are given in [Table A2.4](#) and [Table A2.5](#) respectively.

A2.5 Contraction—Contraction effects can be calculated with Eq A2.6.

$$\beta = 2.5(1 - \gamma^2) \quad (\text{A2.6})$$

A2.6 Enlargement—Enlargement effects can be calculated with Eq A2.7.

$$\beta = \frac{5(1 - \gamma^2)^2}{\gamma^4} \quad (\text{A2.7})$$

A2.7 Mean Water Droplet Diameter:

A2.7.1 The mean water droplet diameter d may be estimated using Eq A2.8.

$$d = 0.3625 \left(\frac{\sigma}{\rho} \right)^{0.6} E^{-0.4} \quad (\text{A2.8})$$

where:

σ = the droplet surface tension between water and oil measured in N/m. All formulas and examples in this [Annex A2](#) assume $\sigma = 0.025$ N/m.

A2.7.2 Interfacial tension values may be significantly affected by additives and contaminants. If it is known that the value is other than 0.025 N/m, the water droplet settling velocity W , given in A2.8, should be modified by multiplying by Eq A2.9.

$$\left(\frac{\sigma}{0.025} \right)^{0.5} \quad (\text{A2.9})$$

TABLE A2.5 Dissipation Energy Relationships

Centrifugal pump	$E = 0.125 \frac{\Delta PQ}{\rho D^3}$
Throttling valve	$E = \frac{\Delta PV}{20\rho D}$
Flow nozzle	$E = 0.022 \frac{Vj^3}{\phi}$

A2.8 Water Droplet Settling Velocity

A2.8.1 The determination of either of the dispersion factors requires a knowledge of the water droplet settling rate, W . This can be calculated using the relationship in Eq A2.10.

$$W = \frac{855(\rho_d - \rho)E^{-0.8}}{\nu\rho^{2.2}} \quad (\text{A2.10})$$

where:

ρ_d = the water density. For salt water (from wells or tankers) a suggested value is 1025 Kg/m³ if the actual one is not available.

A2.8.2 If the mean water concentration is higher than 5 %, multiply W by 1.2.

A2.9 Turbulence Characteristic

A2.9.1 Determination of either of the dispersion factors requires the turbulence characteristics ε/D to be evaluated using Eq A2.11.

$$\frac{\varepsilon}{D} = 6.313 \times 10^{-3} V^{0.875} D^{-0.125} \nu^{0.125} \quad (\text{A2.11})$$

A2.10 Verification of an Existing Sampler Location—It is important to select the worst case conditions in the following sequence:

A2.10.1 Determine the desired profile concentration ratio C_1/C_2 and, using [Table A2.2](#), the corresponding value of G .

A2.10.2 Determine, using [Fig. A2.1](#), which pipeline fittings within $30D$ upstream of the sampler are most likely to provide adequate dispersion.

A2.10.3 Estimate the energy available from each of the most likely fittings using either of the methods described in [A2.4](#).

A2.10.4 Calculate the value of G from the highest value of available energy obtained in step (c) using the formulas presented in [A2.3](#), [A2.8](#), and [A2.9](#).

A2.10.5 Obtain the C_1/C_2 ratio from [Table A2.2](#).

A2.10.6 Check that the calculated C_1/C_2 (or G) value is higher than the desired value obtained in [A2.10.1](#). If it is, the

TABLE A2.4 Dissipation Energy Factors (β)

NOTE 1— n is the number of bends of radius r in a pipe of diameter D .

NOTE 2—The spacing between the bends may affect the degree of dispersion. For this relationship to hold, the distance between each bend should not exceed 30 pipe diameters.

r/d	1	1.5	2	3	4	5	10
$n = 1$	1.27	1.25	1.23	1.22	1.18	1.15	1.07
$n = 2$	1.55	1.50	1.48	1.45	1.38	1.30	1.13
$n = 3$	1.90	1.80	1.75	1.70	1.56	1.44	1.18
$n = 4$	2.20	2.10	2.00	1.93	1.72	1.56	1.23
$n = 5$	2.60	2.40	2.30	2.20	1.90	1.70	1.28

sampler location should prove suitable for the application. If not, remedial action should be taken.

A2.11 Selection of a Suitable Sampler Location—It is again very important to select the worst case and continue the above sequence (A2.10.1-A2.10.6).

A2.11.1 Determine if the desired profile concentration ratio C_1/C_2 and, using **Table A2.2**, the corresponding value of G .

A2.11.2 Determine the turbulence characteristic ε/D as described in A2.9.

A2.11.3 Calculate the water droplet settling rate using Eq A2.12.

$$W = \frac{\varepsilon/D}{G} \quad (\text{A2.12})$$

A2.11.4 Determine the energy required to produce the desired profile concentration ratio using the formula presented in A2.8 re-written in the form of Eq A2.13.

$$E_r = \frac{4630}{\rho^{2.75}} \left[\frac{\rho_d - \rho}{vW} \right]^{1.25} \quad (\text{A2.13})$$

A2.11.5 Select from **Fig. A2.1** the available piping elements most likely to provide adequate energy dissipation.

A2.11.6 Calculate the dissipation energy E for the selected piping elements using either of the methods described in **A2.4**.

A2.11.7 Compare E_r with E to determine if an acceptable profile can be achieved. If for any piping element $E > E_r$, then a satisfactory profile can be achieved using that element. If $E < E_r$ for all piping elements, then additional dissipation energy must be provided. This can be done by reducing the pipe diameter (a length $> 10D$ is recommended) by introducing an additional piping element or by incorporating a static or dynamic mixer.

A2.11.8 If the flow rate has been increased by reducing the pipe diameter, repeat steps **A2.11.2-A2.11.7**.

A2.11.9 If a new piping element has been introduced into the system without changing the flow rate, check, using step **A2.11.6**, that its dissipation energy is larger than the best so far achieved and, if so, proceed to step **A2.11.7**.

A2.11.10 If a static or dynamic mixer is considered, then the manufacturer should be consulted as to its design and application.

A2.12 Examples of Verification of an Existing Sampler Location:

A2.12.1 Using the procedure of **A2.10**, for an installation in a 500 mm pipe where the most severe operating conditions are represented by:

$$V = 2 \text{ m/s} \quad (\text{A2.14})$$

$$\rho = 850 \text{ kg/m}^3$$

$$v = 8 \text{ cSt}$$

$$\rho_d = 1025 \text{ kg/m}^3$$

A2.12.1.1 The desired C_1/C_2 ratio is 0.9, from **Table A2.2**, $G = 10$.

A2.12.1.2 The pipeline fittings within $30D$ upstream of the sampler are a globe valve, an enlargement with diameter ratio,

$\gamma = 0.5$ and two 90° bends. Then, from **Fig. A2.1** the globe valve or the enlargement is clearly most likely to provide adequate dispersion.

A2.12.1.3 The energy available may be calculated using either Method A or B of **A2.4**. However, only K values are given for the globe valve, therefore, these must be used to compare the likely mixing effects of the globe valve and the enlargement.

$$\text{Globe valve } K = 6 \quad (\text{Table A2.4}) \quad (\text{A2.15})$$

$$\text{Enlargement } K = \frac{(1 - \gamma^2)^2}{\gamma^4} = 9 \quad (\text{Table A2.3})$$

The enlargement has the higher K value and should be used in the following calculations. **A2.4** may be used for the rest of the calculation. (a) Using Method A, **A2.4**:

$$E = \frac{\Delta PV}{\Delta X} \text{ W/kg} \quad (\text{A2.16})$$

or as:

$$\Delta P = \frac{K\rho V^2}{2} \text{ W/kg} \quad (\text{A2.17})$$

then:

$$E = \frac{KV^3}{2\Delta X} \text{ W/kg} \quad (\text{A2.18})$$

and using $\Delta X = 10D$:

$$E = \frac{9 \times 2^3}{2 \times 10 \times 0.5} = 7.2 \text{ W/kg} \quad (\text{A2.19})$$

A2.12.1.4

$$G = \frac{\varepsilon/D}{W} \quad (\text{A2.20})$$

$$\frac{\varepsilon}{D} = 6.313 \times 10^{-3} V^{0.375} D^{-0.125} v^{0.125} \text{ m/s} \quad (\text{A2.21})$$

$$W = \frac{855(\rho_d - \rho)}{v\rho^{2.2}} E^{-0.8} \text{ m/s} \quad (\text{A2.22})$$

$$\therefore \frac{\varepsilon}{D} = 6.313 \times 10^{-3} \times 2^{0.875} \times \frac{1}{0.5^{0.125}} \times 8^{0.12}$$

$$= 16.37 \times 10^{-3} \text{ m/s} \quad (\text{A2.23})$$

and

$$W = \frac{855(1025 - 850)}{8 \times 850^{2.2}} \times \frac{1}{7.2^{0.8}} \\ = 1.38 \times 10^{-3} \text{ m/s} \quad (\text{A2.24})$$

$$\therefore G = \frac{16.37 \times 10^{-3}}{1.38 \times 10^{-3}} = 11.83 \quad (\text{A2.25})$$

A2.12.1.5 From **Table A2.2** the C_1/C_2 ratio is greater than 0.9.

A2.12.1.6 The calculated value of C_1/C_2 is greater than the required value, and therefore, adequate conditions for sampling exist.

A2.12.1.7 Using Method B, **A2.4**:

$$E = \beta E_0 \text{ W/kg} \quad (\text{A2.26})$$

$$\beta = \frac{5(1 - \gamma^2)^2}{\gamma^4} = 45 \quad (\text{Table A2.4}) \quad (\text{A2.27})$$

$$E_0 = 0.005v^{0.25}D^{-1.25}V^{2.75} \quad (\text{A2.28})$$

$$\begin{aligned} \therefore E &= 45 \times 0.005 \times 8^{0.25} \times \frac{1}{0.5^{1.25}} \times 2^{2.75} \\ &= 6.0545 \text{ W/kg} \end{aligned} \quad (\text{A2.29})$$

A2.12.1.8

$$G = \frac{\varepsilon/D}{W} \quad (\text{Table A2.2}) \quad (\text{A2.30})$$

$$\varepsilon/D = 16.37 \times 10^{-3} \text{ m/s} \quad (\text{A2.31})$$

as calculated for Method A:

$$\begin{aligned} W &= \frac{855(\rho_d - \rho)}{v\rho^{2.2}} E^{-0.8} \text{ m/s} \quad (\text{A2.32}) \\ &= \frac{855(1025 - 850)}{8 \times 850^{2.2}} \times \frac{1}{6.0545^{0.8}} \end{aligned}$$

$$= 1.59 \times 10^{-3} \text{ m/s} \quad (\text{A2.33})$$

$$\therefore G = \frac{16.37 \times 10^{-3}}{1.59 \times 10^{-3}} = 10.29 \quad (\text{A2.34})$$

A2.12.1.9 Follow A2.12.1.5 and A2.12.1.6 as for Method A.

A2.12.2 *Example of Selection of a Suitable Sampler Location Using the Procedure of A2.11:*

A2.12.2.1 The proposed pipeline configuration consists of a 600 mm line enlarging to 800 mm followed by a line of three 90° bends each with an r to D ratio of 1 and finally a throttling valve with the differential pressure of one bar. The most severe operating conditions are represented by the following conditions:

$$V = 1.5 \text{ m/s} \quad (\text{A2.35})$$

$$\rho = 820 \text{ kg/m}^3$$

$$v = 7 \text{ cSt}$$

$$\rho_d = 1025 \text{ kg/m}^3$$

A2.12.2.2 The desired C_1/C_2 ratio is 0.9; then, from Table A2.2, $G = 10$.

A2.12.2.3 The turbulence characteristic from A2.9 is:

$$\varepsilon/D = 6.313 \times 10^{-3} V^{0.875} D^{-0.125} v^{0.125} \text{ m/s} \quad (\text{A2.36})$$

$$\begin{aligned} &= 6.313 \times 10^{-3} \times 0.5^{0.875} \times \frac{1}{0.8^{0.125}} \times 7^{0.125} \\ &= 11.81 \times 10^{-3} \text{ m/s} \end{aligned} \quad (\text{A2.37})$$

A2.12.2.4 The water droplet settling velocity is:

$$W = \frac{\varepsilon/D}{G} = \frac{11.81 \times 10^{-3}}{10} = 1.18 \times 10^{-3} \text{ m/s} \quad (\text{A2.38})$$

A2.12.2.5 The energy dissipation rate required per Eq A2.39 is:

$$E_r = \frac{4630}{\rho^{2.75}} \left[\frac{\rho_d - \rho}{vW} \right]^{1.25} \quad (\text{A2.39})$$

$$\begin{aligned} &= \frac{4630}{820^{2.75}} \left(\frac{1025 - 820}{7 \times 1.18 \times 10^{-3}} \right)^{1.25} \\ &= 13.99 \text{ W/kg} \end{aligned} \quad (\text{A2.40})$$

A2.12.2.6 From Fig. A2.1 the throttling valve is clearly the element most likely to provide sufficient energy dissipation.

A2.12.2.7 Method B is the only one to provide an energy dissipation formula for a throttling valve; see Table A2.5.

$$\therefore E = \frac{\Delta PV}{20\rho D} \text{ W/kg} \quad (\text{A2.41})$$

$$\begin{aligned} &= \frac{1 \times 10^5 \times 1.5}{20 \times 820 \times 0.8} [1 \text{ bar} = 10^5 \text{ Pascal}] \\ &= 11.43 \text{ W/kg} \end{aligned}$$

A2.12.2.8 The energy dissipation rate E provided by the throttling valve is less than required E_r . Therefore, a G value of 10 has not been achieved and sampling from this location is unlikely to prove adequate. If the enlargement from 600 to 800 mm is moved downstream of the throttling valve and sampling location, then the following recalculation applies with $D = 0.6$ m and $V = 2.67$ m/s:

A2.12.2.9

$$\begin{aligned} \frac{\varepsilon}{D} &= 6.313 \times 10^{-3} \times 2.67^{0.875} \times \frac{1}{0.6^{0.125}} \times 7^{0.125} \text{ m/s} \\ &= 20.25 \times 10^{-3} \text{ m/s} \end{aligned} \quad (\text{A2.42})$$

A2.12.2.10

$$W = \frac{\varepsilon/D}{G} = \frac{20.25 \times 10^{-3}}{10} = 2.02 \times 10^{-3} \text{ m/s} \quad (\text{A2.43})$$

A2.12.2.11

$$\begin{aligned} E_r &= \frac{4630}{820^{2.75}} \left[\frac{1025 - 820}{7 \times 2.02 \times 10^{-3}} \right]^{1.25} \text{ W/kg} \\ &= 7.13 \text{ W/kg} \end{aligned} \quad (\text{A2.44})$$

A2.12.2.12 Unchanged from previous calculation.

A2.12.2.13

$$\begin{aligned} E &= \frac{\Delta PV}{20\rho D} \text{ W/kg} \quad (\text{A2.45}) \\ &= \frac{10^5 \times 2.67}{20 \times 820 \times 0.6} \\ &= 27.10 \text{ W/kg} \end{aligned} \quad (\text{A2.46})$$

A2.12.2.14 The energy dissipation rate provided by the throttling valve located in the smaller diameter pipe is more than sufficient to give a G value of 10. Adequate sampling should therefore be possible.

A3. ACCEPTANCE METHODOLOGIES FOR SAMPLING SYSTEMS AND COMPONENTS

A3.1 Definitions of Terms Specific to This Standard—The following definitions are included as an aid in using **Table A3.1** and **Table A3.2** for profile test data and point averages and deviation:

A3.1.1 minimum flow rate, *n*—the lowest operating flow rate, excluding those rates which occur infrequently (that is, 1 of 10 cargoes) or for short time periods (less than 5 min).

A3.1.2 overall profile average, *n*—the average of all point averages.

A3.1.3 point, *n*—a single sample in a profile.

A3.1.4 point average, *n*—the average of the same point from all profiles (excluding profiles with less than 1.0 % water).

A3.1.5 profile, *n*—multi-point samples taken simultaneously across a diameter of the pipe.

TABLE A3.1 Allowable Deviations for the Single and Dual Sampler Water Injection Acceptance Tests (Volume %)

NOTE 1—The reference to tanks or meters refers to the method used to determine the volume of crude oil or petroleum in the test.

NOTE 2—Deviations shown reflect use of the Karl Fischer test method described in Test Method **D4928** (API *MPMS* Chapter 10.9) for water.

NOTE 3—Interpolation is acceptable for water concentrations between values shown in the table. For example, if the total water is 2.25 % the allowable deviation using tank gages would be 0.175 % and 0.135 % if using meters.

NOTE 4—This table is based, in part, on statistical analysis of a data base consisting of 36 test runs from 19 installations. Due to the number of data, it was not possible to create separate data bases for analysis by the volume determination method, that is, by tank or meter. Therefore, it was necessary to treat the data as a whole for analysis. The data base is valid for the water range 0.5 % to 2.0 %.

NOTE 5—The reproducibility standard deviation calculated for the data, at a 95 % confidence level, has been used for the meter values shown in the table in the water range 0.5 to 2.0 %. Assigning these values to the meter is based on a model that was developed to predict standard deviations for volume determinations by tanks and meters. Values shown in the table for the tank, in the range 0.5 % to 2.0 %, were obtained by adding 0.04 % to the meter values in this water range. The value of 0.04 % was derived from the aforementioned model as the average bias between tank and meter volume determinations.

NOTE 6—As there is insufficient test data for water levels over 2.0 %, values shown in the table above 2.0 % have been extrapolated on a straight line basis using the data in the 0.5 % to 2.0 % range.

NOTE 7—In order to develop a broader data base, owners of systems are encouraged to forward a copy of test data using test data sheets as shown in **Annex A6** to the American Petroleum Institute, Industry Services Department, 1220 L Street, N.W., Washington, DC 20005.

Total Water ($W_{bl} + W_{inj}$)	Allowable Deviations	
	Using Tank Gages	Using Metres
0.5	0.13	0.09
1.0	0.15	0.11
1.5	0.16	0.12
2.0	0.17	0.13
2.5	0.18	0.14
3.0	0.19	0.15
3.5	0.20	0.16
4.0	0.21	0.17
4.5	0.22	0.18
5.0	0.23	0.19

TABLE A3.2 Typical Profile Test Data, in Percent Volume of Water

NOTE—For invalid sample or missed data point, the point should be shown as missing data and the remaining data averaged.

Profile	Point (% volume – water)				
	A Bottom	B ¼ Point	C Midpoint	D ¾ Point	E Top
1	0.185	0.096	0.094	0.096	0.096
2	0.094	0.182	0.135	0.135	0.135
3	13.46	13.72	13.21	12.50	12.26
4	8.49	7.84	8.65	8.65	8.33
5	6.60	7.69	7.69	6.60	8.00
6	6.73	7.02	6.48	6.73	5.38
7	7.88	6.73	6.73	7.27	5.96
8	2.78	3.40	3.27	3.08	2.88
9	1.15	1.36	1.54	1.48	1.32
10	0.58	0.40	0.48	0.55	0.47

A3.2 Acceptance Testing—Water Injection Volume Balance Tests

A3.2.1 This annex describes three test methods shown to be acceptable in proving the performance of pipeline and marine automatic pipeline sampling systems, that is, single sampler, dual sampler and component testing. These methods have equal validity and the order listed should not be construed as one method having preference over another. Once a system design has been proven, subsequent systems of the same design (for example, LACT units), including piping configuration and similar service need not be tested. Refer to Section 16 for verification of systems of the same design.

A3.2.2 The following procedures are presented for the testing of systems to identify water in petroleum. The same approach may be modified to apply to petroleum blending systems.

A3.2.3 The single and dual sampler tests are designed to test the entire sampling system starting with the stream condition in the pipeline through collection and analysis of the sample. These are volume balance tests in which a known amount of water is injected into a known volume of oil of a known baseline water content. As these volumes pass the sampler under test, a sample is collected and the results analyzed for comparison against the known baseline water plus injected water.

A3.2.4 The single sampler test requires that an assumption be made concerning the baseline water content during the time that test water is injected. Successful tests are dependent upon a constant baseline oil throughout the test. If a constant baseline oil cannot be ensured, inconclusive results will be obtained.

A3.2.5 In the dual sampler test, the first sampler (that is, baseline sampler) is used to measure the baseline water content during the test. Test water is injected between the baseline and primary samplers. The primary sampler (one under test) is used to collect the baseline plus injected water sample. It is not necessary that the two sampling installations be of identical or similar design.

A3.3 Preparations Prior to Acceptance Test

A3.3.1 Test the sample receiver and mixer as outlined in Practice D5854 (API MPMS Chapter 8.3), Annex A2 (B.4). During the sampler acceptance test, water injection should last at least 1 h. The corresponding sample volume collected during a sampler acceptance test is usually less than the volume expected under normal conditions. Therefore, if the sample volume to be collected during the sampler acceptance test is less than the minimum volume at which the receiver and mixer have been tested, the receiver and mixer must be tested prior to the acceptance test in accordance with Annex A2 (B.4) of Practice D5854 (API MPMS Chapter 8.3) using the oil and volume that are to be sampled.

A3.3.2 Determine the method and accuracy by which the water and oil volumes will be measured. Water injection meters should be installed and proven in accordance with API MPMS Chapters 4, 5 and 6. Oil volumes should be measured by tank gauge or meter in accordance with applicable API MPMS Chapters 3, 4, 5 and 6 guidelines.

A3.3.3 Locate the water injection point upstream of the elements expected to produce the stream conditioning for the sampling system. Be aware of potential traps in the piping which may prevent all of the injected water from passing the sample point. Exercise care to ensure that the location and manner in which water is injected does not contribute additional mixing energy at the point of sampling which would distort the test results. Equipment or facilities used to inject water should be in accordance with local safety practices.

A3.3.4 Review the normal operating conditions of the pipeline in terms of flow rates and crude types. Select the most common, worst case conditions to test the sampling system. The worse case is commonly the lowest normal flow rate and the highest API gravity crude normally received or delivered.

A3.3.5 In the case of the single sampler acceptance test, a source of constant water content for oil must be identified for the test. If possible, it is suggested that this oil be isolated as changes in the baseline water content can produce inconclusive test results.

A3.4 Single Sampler—Acceptance Test

A3.4.1 Purge the system at a sufficiently high flow rate to displace free water which may be laying in the pipeline system upstream of the automatic sampling system (refer to Fig. A3.1).

A3.4.2 Establish the flow rate for the test.

A3.4.3 Collect the first baseline sample(s). A baseline sample may be a composite sample collected in a separate sample receiver or several spot samples collected at intervals directly from the sample extractor.

A3.4.4 Record the initial oil volume by tank gauge or meter reading and simultaneously begin collecting grabs in the sample receiver.

A3.4.5 Record the initial water meter reading. Then turn the water on and adjust injection rate.

A3.4.6 A minimum of 1 h is recommended for the water injection.

A3.4.7 Turn the water off and record the water meter reading.

A3.4.8 Continue sampling into the receiver until the injected water is calculated to have passed the sampler.

A3.4.9 Stop the collection of test sample and simultaneously record the oil volume by tank gauge or meter reading.

A3.4.10 Collect the second baseline sample(s).

A3.4.11 Analyze the baseline samples.

A3.4.12 Analyze the test sample.

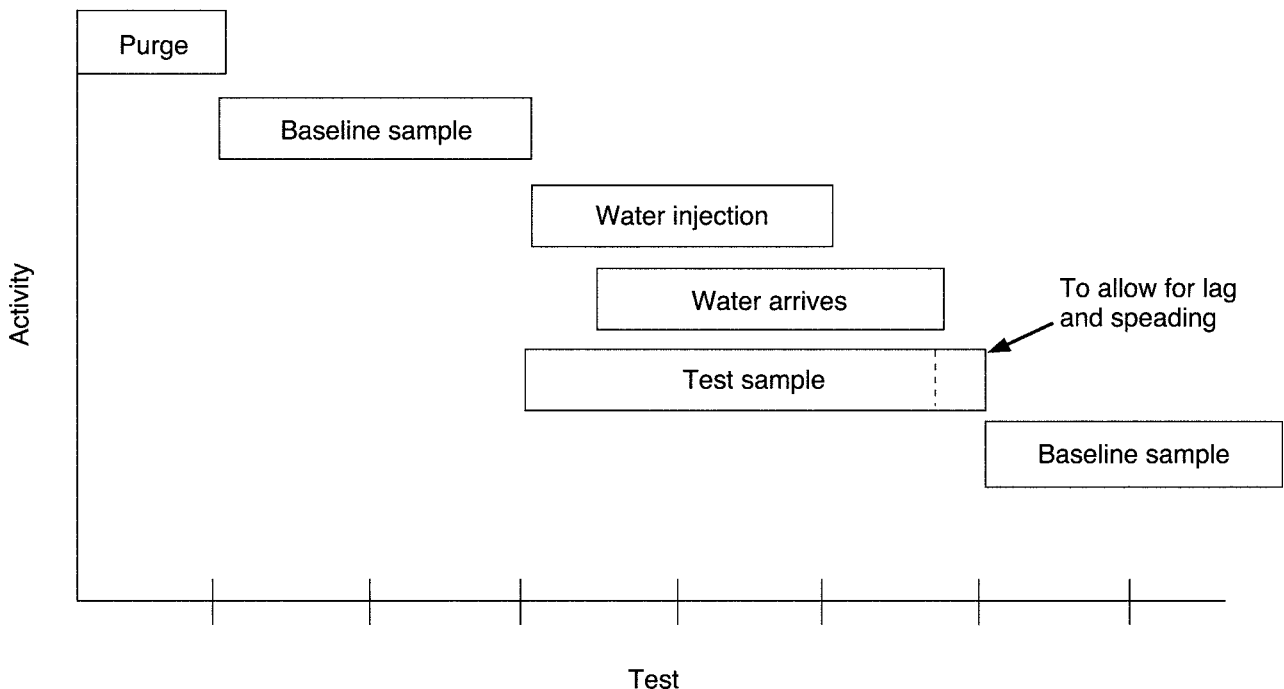

NOTE—Times are calculated based on minimum oil flow rate and the distance between the injection and the sample point.

FIG. A3.1 Sequence of Acceptance Test Activities

A3.4.13 Using the following Eq A3.1, calculate the deviation between the water in the test sample minus the water in the baseline, corrected to test conditions, compared to the amount of water injected.

$$Dev = (W_{\text{test}} - W_{\text{bl}}) - W_{\text{inj}} \quad (\text{A3.1})$$

where:

- Dev = deviation, vol %,
- W_{test} = water in test sample, vol %,
- W_{bl} = baseline water adjusted to test conditions, vol %
 $= W_{\text{avg}} \times \frac{TOV - V}{TOV}$,
- W_{avg} = average measured baseline water, vol %,
- TOV = total observed volume (test oil plus injected water) that passes the sampler (barrels),
- V = volume of injected water in barrels, and
- W_{inj} = water injected during test, vol %
 $= \frac{V}{TOV} \times 100$

A3.4.14 Repeat A2.4.3 through A3.4.13 until two consecutive tests that meet the criteria in A3.6.2 have been obtained.

A3.4.15 When production water is used, make correction for dissolved solids as applicable.

A3.5 Dual Sampler—Proving Test

A3.5.1 The dual sampler test is a two-part test. In the first part, the two samplers are compared to one another at the baseline water content. In part two of the test, water is injected between the two samplers to determine if the baseline water plus injected water is detected by the primary sampler. Refer to Annex A6.

A3.5.2 Baseline Test Procedure:

A3.5.2.1 Purge system to remove free water.

A3.5.2.2 Establish steady flow in line.

A3.5.2.3 Start baseline sampler. Record tank gauge or meter reading.

A3.5.2.4 Start primary sampler after pipeline volume between samplers has been displaced.

A3.5.2.5 Stop baseline sampler after collecting targeted sample volume. A minimum of 1 h is recommended. Record tank gauge or meter reading.

A3.5.2.6 Stop primary sampler after pipeline volume between baseline and primary samplers has been displaced.

A3.5.2.7 Analyze test samples.

A3.5.2.8 Compare results and make sure they are within acceptable tolerance as per Table A3.1 before proceeding.

A3.5.3 Water Injection Test:

A3.5.3.1 Record water meter reading.

A3.5.3.2 Start baseline sampler, injection of water and record tank gauge or meter reading all in rapid succession.

A3.5.3.3 Start primary sampler immediately prior to arrival of injected water.

A3.5.3.4 Collect targeted sample volume with baseline sampler.

A3.5.3.5 Stop baseline sampler, record tank gauge or meter reading and shut off water injection all in rapid succession.

A3.5.3.6 Record water meter reading.

A3.5.3.7 Stop primary sampler after displacement of pipeline volume between baseline and primary samplers.

A3.5.3.8 Analyze test samples.

A3.5.3.9 Repeat A3.5.2.2 through A3.5.3.6 until two consecutive tests that meet the criteria in A3.6.3 have been obtained for both parts of the test.

A3.6 Approval for Custody Transfer

A3.6.1 The acceptance test is valid and the automatic sampling system is acceptable for custody transfer if two consecutive test runs meet the following criteria:

A3.6.2 Single Sampler Test:

A3.6.2.1 The difference in the percent water in the beginning and ending baselines is 0.1 % or less, and

A3.6.2.2 The deviation between the test sample and the known baseline plus injected water is within the limits shown in Table A3.1.

A3.6.3 Dual Sampler Test:

A3.6.3.1 The difference between the two samplers during the baseline test must be within 0.1 %, and

A3.6.3.2 The difference between the second sampler (test sampler) and the baseline sampler plus injected water must be within the limits shown in Table A3.1.

A3.6.4 Procedures to Follow if the Acceptance Test Fails:

A3.6.4.1 Ensure volume of oil was calculated and recorded correctly.

A3.6.4.2 Ensure volume of water was calculated and recorded correctly. Ensure scaling factor is correct or the meter factor has been applied to obtain correct volume, or both.

A3.6.4.3 If inadequate stream conditioning in the pipeline is suspected, validate the sample point by one of the following:

- (1) Annex A2 to estimate the water-in-oil dispersion
- (2) A multiple point profile test as described in A3.7.1.

A3.7 Component Performance Test

A3.7.1 *Profile Test to Determine Stream Condition*—The extent of stratification or non-uniformity of concentration can be determined by taking and analyzing samples simultaneously at several points across the diameter of the pipe. The multipoint probe shown in Fig. A3.2 is an example of a profile probe design. This test should be conducted in the same cross-section of pipe where the sample probe will be installed.

A3.7.1.1 *Criteria for Uniform Dispersion and Distribution*—A minimum of five profile tests meeting criteria in A3.8.2. If three of those profiles indicate stratification, the mixing in the line is not adequate.

A3.7.1.2 *Profile Probe*—A probe with a minimum of five sample points is recommended for 30-cm (12-in.) pipe or larger. Below 30-cm (12-in.) pipe size, three sample points are adequate.

A3.7.1.3 *Sampling Frequency*—Profile samples should not be taken more frequently than at 2 min intervals.

A3.7.1.4 *Probe Orientation*—Profiles in horizontal lines must be taken vertically, where as profiles in vertical lines should be taken horizontally.

A3.7.1.5 *Test Conditions*—The test should be set up to measure the worst case conditions including the minimum flow rate and lowest flow viscosity and density or other conditions as agreed upon.

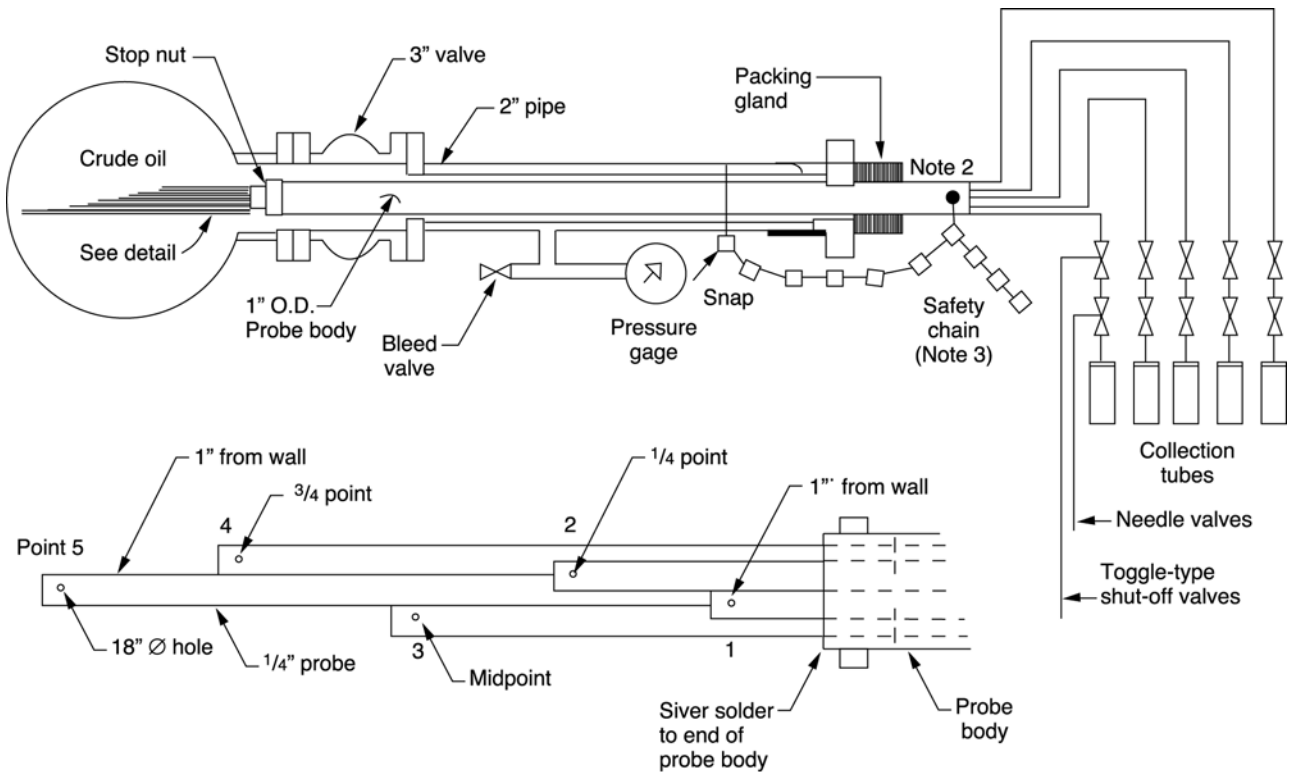

NOTE 1—For pipes less than 30 cm (12 in.), delete the 1/4 and 1/4 points.
 NOTE 2—The punch mark on probe sleeve identifies the direction of probe openings.
 NOTE 3—When the probe is fully inserted, take up the slack in the safety chains and secure the chains tightly.
 NOTE 4—The probe is retractable and is shown in the inserted position.

FIG. A3.2 Multi Probe for Profile Testing

A3.7.1.6 *Water Injection*—The water injection method described in testing automatic sampling systems (see A3.2 and A3.3.3) is recommended.

A3.7.1.7 *Sampling*—Sampling should begin 2 min before the calculated water arrival time and continue until at least ten profiles have been taken.

NOTE A3.1—Probe installation and operation are covered in A3.9. As a safety precaution, the probe should be installed and removed during low pressure conditions. However, the probe should be equipped with safety chains and stops to prevent blow-out should it be necessary to remove it during operation conditions.

A3.8 Application of Dispersion Criteria

A3.8.1 Table A3.2 lists data accumulated during a typical profile test. Units are percent volume of water detected. Approximately 1000 barrels of seawater were added to a center

compartment of a 76 000 dead weight ton crude oil tanker. The quantity of water was verified by water cut measurements shortly before the loading operation.

A3.8.2 To apply the dispersion criteria, it is best to eliminate all profiles with less than 0.5 % water and the profile taken in the leading edge of the water (which occurs in Profile 3 of Table A3.2). Typically, a profile of the leading edge is erratic with respect to water dispersion. While it is a useful means of verifying arrival time, it hinders evaluation of profile data and can cause an unnecessarily reduced profile test rating. Calculate the point average and deviation for all other profiles with 1 % or more water. (See Table A3.3.)

A3.9 *Water Profile Test Procedures*—Refer to Fig. A3.2 while following the steps of this procedure.

TABLE A3.3 Calculation of Point Averages and Deviation

NOTE 1—The system is rated with respect to the worst point average in the test: point average E has the largest deviation (−0.28).
 NOTE 2—For representative sampling, the allowable deviation is 0.05 % water for each 1 % water in the overall profile average. In this example, the allowable deviation is given by the (5.69 × 0.05) % W = ±0.28 % W.

	Point (% volume – water)					Average E
	A	B	C	D	E	%
Average of profiles 4 through 9	5.61	5.67	5.73	5.64	5.31	5.59
Deviation from overall profile average (Note 1) (% water)	+ 0.02	+ 0.08	+ 0.14	+ 0.05	−0.28	
Allowable deviation (Note 2)						(5.59 × 0.05) % water = ±0.28 % water

A3.9.1 Install profile probe in line. Check that the probe is properly positioned and safely secured.

A3.9.2 Position a slop can under the needle valves. Open the shut-off and needle valves and purge the probes for one minute (or sufficient time to purge 10 times the volume in the probe line).

A3.9.3 Adjust needle valves so that all sample containers fill at equal rates.

A3.9.4 Close shut-off valves.

A3.9.5 Open the shut-off valves, purge the probe lines, and quickly position the five sample containers under the needle valves. Close shut-off valves.

A3.9.6 Repeat A3.9.5 at intervals of not less than 2 min until a minimum of ten profiles have been obtained.

A3.10 Sample Probe/Extractor Test

A3.10.1 The grab size should be repeatable within $\pm 5\%$ over the range of operating conditions. Operating parameters that may affect grab size are sample viscosity, line pressure, grab frequency and back pressure on the extractor.

A3.10.2 Test the sample probe/extractor by collecting 100 grabs in a graduated cylinder and calculate the average grab size. Perform the test at the highest and the lowest oil viscosity, pressure and grab frequency.

A3.10.3 The average grab size will determine if the target number of grabs will exceed filling the sample receiver above the proper level. The average grab size is also used in determining the sampler performance (see Annex A4 and Annex A5).

A3.11 Special Flow Meter Test

A3.11.1 If custody transfer meters are used, verification of the flow meter calibration is not necessary.

A3.11.2 Special types of meters, such as those described in 12.2, can be verified by comparing the meter pacing the extractor with tank gages or custody transfer meters. Conditions for the test are:

A3.11.2.1 The test should be conducted at the average flow rate experienced during normal operations.

A3.11.2.2 The flow meter must be tested in its normal, operating location to determine if piping configuration affects its accuracy.

A3.11.2.3 When using tank gages as a reference volume, the tank level changes must be large enough to give accurate volume readings.

A3.11.3 Flow meters used for pacing sample extractors should be within $\pm 10\%$ of the volume measured by tank gaging or custody transfer meters.

A4. PERFORMANCE CRITERIA FOR PERMANENT INSTALLATIONS

A4.1 Calculations Prior to Operation

PV_e	Expected parcel volume, m ³
b	Expected extractor grab size, mL
SV_e	Expected sample volume, mL (normally 80 % of receiver capacity)
n	Number of sample grabs expected

$$n = \frac{SV_e}{b} \tag{A4.1}$$

B Frequency of sampling, m³/grab (Controller input)

$$B = \frac{PV_e}{n} \tag{A4.2}$$

A4.2 Data from the Sampling Operation

N	Total number of grabs ordered by the controller
SV	Sample volume collected, mL
SV_c	Sample volume calculated, mL
PV_s	Parcel volume measured by sampler flow sensing device, m ³
PV_{co}	Custody transfer or outturn parcel volume, m ³

A4.3 *Calculation of Performance Report*—The following calculations can be helpful in evaluating if a sample is representative:

A4.3.1 *Grab Factor (GF):*

$$GF = \frac{SV}{N \times b} = 1 \pm 0.05 \tag{A4.3}$$

A4.3.1.1 Components and variables involved:

- (1) Average grab size,
- (2) Controller-to-probe link, and
- (3) Probe operation.

A4.3.2 *Performance Factor (PF):*

$$PF = \frac{SV}{SV_c} = 1 \pm 0.10 \tag{A4.4}$$

$$= \frac{SV}{\frac{PV_s}{B} \times b} = 1 \pm 0.10 \tag{A4.5}$$

A4.3.3 *Flow Sensor Accuracy (SA):*

$$SA = \frac{PV_{co}}{PV_s} = 1 \pm 0.10 \tag{A4.6}$$

A4.3.4 *Sampling Time Factor (SF):*

$$\text{Sampling Factor} = \frac{\text{Total sampling time}}{\text{Total parcel time}} = 1 \pm 0.05 \tag{A4.7}$$

Time parcel began	_____
Time parcel completed	_____
Total parcel time	_____
Time sampler begins operation	_____
Intermittent outages	_____
Time sampler stops operation	_____
Total sampling time	_____

Note: Record actual times sampler is not in service.

A4.3.5 Sampler installation was tested according to Practice D4177 (API MPMS Chapter 8.2):

Yes _____ No _____ Date tested _____

A4.3.5.1 Components and variables involved are (1) average grab size, (2) flow sensor-to-controller link, (3) controller, (4) controller-to-probe link, (5) probe operation, and (6) flow sensor accuracy.

A5. PERFORMANCE CRITERIA FOR PORTABLE SAMPLING UNITS

A5.1 Representative sampling is more difficult to document and verify when a portable sampler is used. The flow sensing device is usually limited in accuracy and turndown. Stream conditioning is usually limited to piping elements and flow velocity. The sampler controller data logging is usually limited. Special precautions and operating procedures with additional record keeping by the operator can overcome these limitations.

A5.2 Calculations Prior to Operation

PV_e	Expected parcel volume, m ³
b	Expected extractor grab size, mL
SV_e	Expected sample volume, mL (normally 80 % of receiver capacity)
n	Number of sample grabs expected

$$n = \frac{SV_e}{b} \quad (A5.1)$$

B	Frequency of Sampling, m ³ /grab (Controller input)
-----	--

$$B = \frac{PV_e}{n} \quad (A5.2)$$

A5.3 Data from the Sampling Operation

N	Total number of grabs ordered by the controller
SV	Sample volume collected, mL
PV_s	Parcel volume measured by sampler flow sensing device, m ³
PV_{co}	Custody transfer or outturn parcel volume, m ³

A5.4 *Calculation of Performance Report*—The following calculations can be helpful in evaluating if a sample is representative:

A5.4.1 Grab Factor (GF):

$$GF = \frac{SV}{N \times b} = 1 \pm 0.05 \quad (A5.3)$$

A5.4.2 Modified Performance Factor (PF_m):

$$PF_m = \frac{SV}{\frac{PV_s}{B} \times b} = 1 \pm 0.10 \quad (A5.4)$$

PV_s is normally not available. When this is the case, use PV_{co} which excludes the effect of flow sensor malfunction or inaccuracy on PF_m . If PV_s is available from the controller, calculate PF as in **Annex A4**.

A5.4.3 *Flow Sensor Accuracy (SA)*—The volume as measured by the sampler(s) flow sensor(s) is normally not available. The volume measured by the flow sensor(s) is calculated from the number of grabs ordered by the controller(s).

$$SA = \frac{N \times B}{PV_{co}} = 1 \pm 0.10 \quad (A5.5)$$

A5.4.4 Sampling Factor (SF):

$$\text{Sampling Factor} = \frac{\text{Total sampling time}}{\text{Total parcel time}} = 1 \text{ at } \pm 0.05 \quad (A5.6)$$

A5.4.5 Stream Conditioning:

A5.4.5.1 For 95 % of the parcel volume, the flow rate in piping ahead of the sampler(s) was a minimum of 2 m/s (6.6 ft/s) Yes _____ No _____

A5.4.5.2 No more than 10 % of the total free water in the tanks/compartments was pumped at flow rates of less than 2 m/s. Yes _____ No _____
The criteria for stream conditioning is met if both answers are “Yes.”

A5.5 *Line and Manifold Data*—Complete forms as outlined in **Figs. A5.1-A5.4** for each sample.

VESSEL _____ LOCATION _____

LOADING _____ DISCHARGE _____ TIME PUMPING BEGINS _____ ENDS _____

DATE PUMPING BEGINS _____

Date	Time	Probe ID (1)		Line No. (1)		Parcel	Calculation (2)	
		Into Service	Out of Service	Into Service	Out of Service	Flow Rate	Velocity at Probe	Velocity Thru Line

NOTE 1—Line No. = Identification letter or number from Fig. A5.3 or Fig. A5.4.

NOTE 2—Velocities should be calculated for lines A to D in Fig. A5.4 as major rate changes occur and arms/hoses are added or removed from service. The same applies to spools I to IV on the vessel. The same applies for lines and spools designated I to IV in Fig. A5.3.

FIG. A5.1 Portable Sampler Operational Data Confirmation of Mixing and Flow Sensor Velocity

Lines from Vessel
Pump Room to Manifold

Vessel Manifold and Sampler Spools

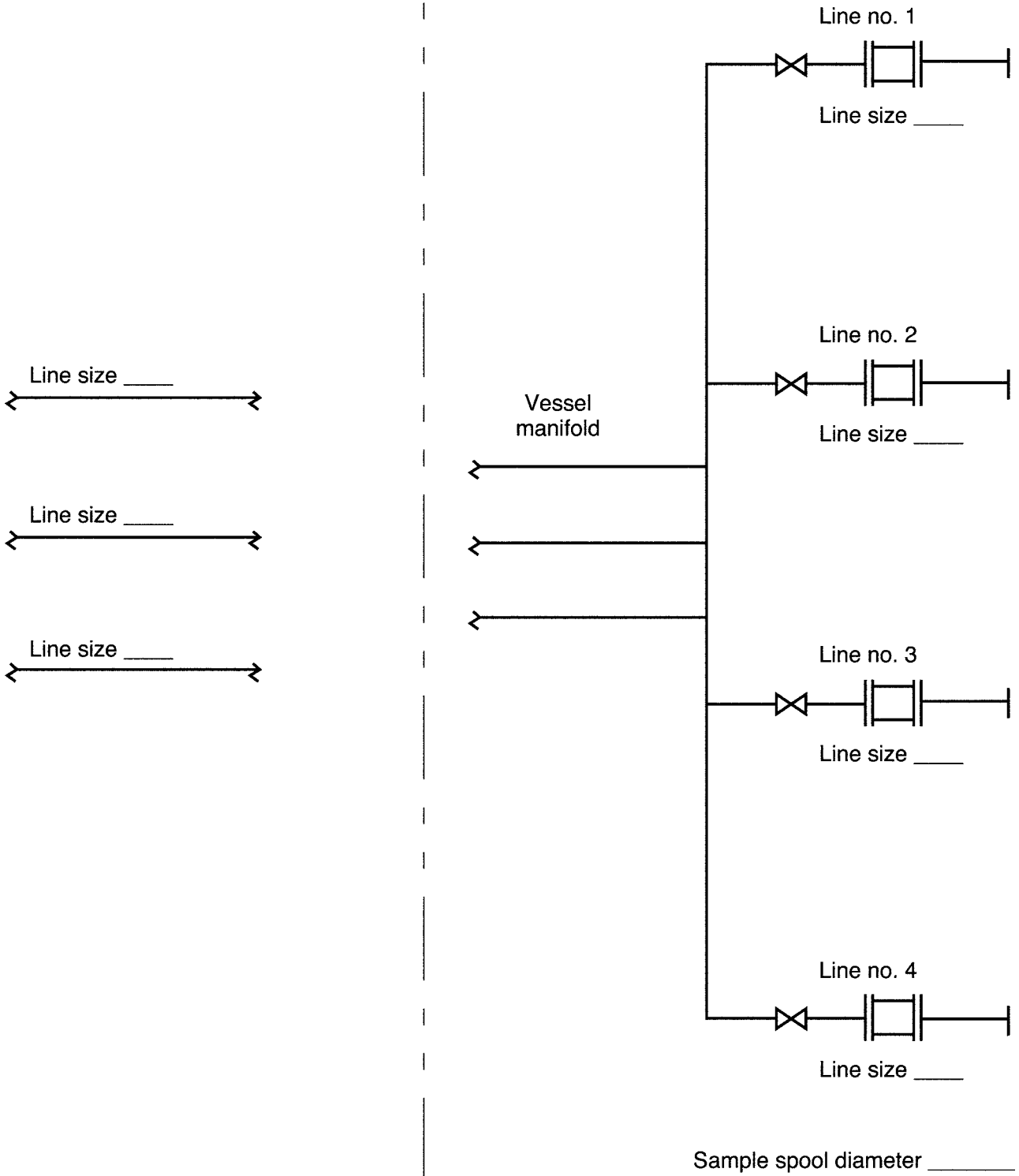

NOTE—In the spaces provided, enter the tank numbers and line sizes used during discharges.
FIG. A5.3 Typical Piping Schematic to be Recorded for Discharges

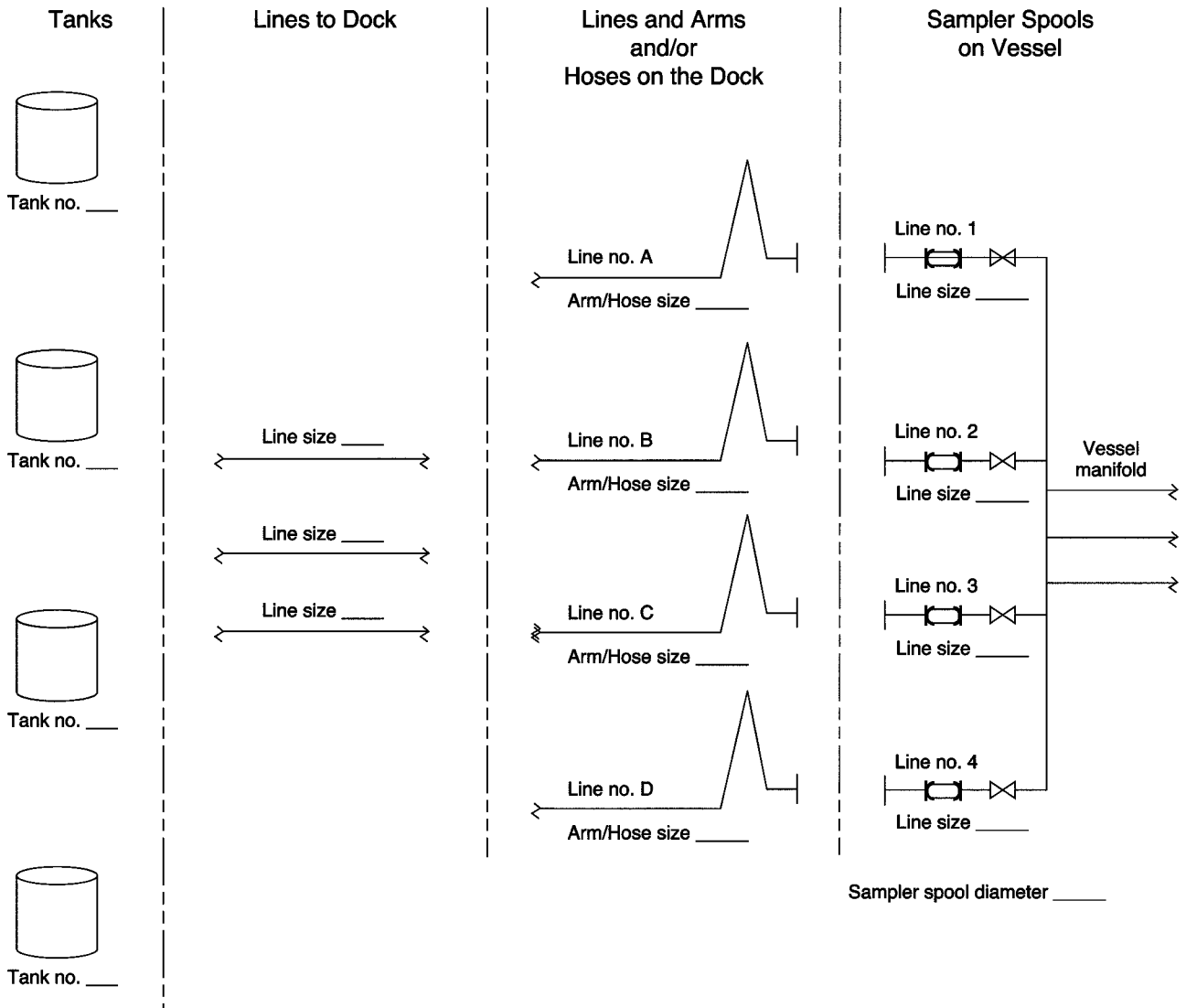

NOTE—In the spaces provided, enter the line sizes used during loading.
FIG. A5.4 Typical Piping Schematic to be Recorded for Loading

A6. SAMPLER ACCEPTANCE TEST DATA

A6.1 Fig. A6.1 is an example of the sampler acceptance test data sheet.

 **D4177 – 95 (2005)**

Company: _____ Location: _____ Sampler ID: _____ Test # _____ of _____

Date: _____ Company Witness: _____ Other Witness: _____

SYSTEM DATA

Crude Grade: _____ Viscosity: _____ API: _____ Flow Rate: _____ bph/m3 Velocity _____ fps/mps Line Size: _____ in.
 _____ cts @ 40C Flow Temp: _____ F/C

Crude Volume Determination by: ____ Meter ____ Tank Tank Increment Vol. _____ bbls/m3	Probe Design: ____ Isokinetic ____ Ell ____ Beveled ____ Plain ____ Other ____ Grab Size(ml)	Probe Orientation: ____ Top ____ Side ____ Bottom ____ Sample Loop	Stream Conditioning: ____ Power Mixing ____ Static Mixer-Vertical ____ Static Mixer-Horizontal ____ Piping Element-Vertical ____ Piping Element-Horizontal ____ None	Laboratory Analysis: ____ Centrifuge ____ Distillation ____ Karl Fischer ____ Mass ____ Volume

Test Water: _____ Fresh; _____ Brackisk; _____ Sea; _____ Production

TEST DATA

Baseline Test Data

1. Single Sampler Method Baseline Test:
 (Wavg) = (1st baseline _____ % + 2nd baseline _____ %) / 2 = _____ %

2. Dual Sampler Method Baseline Test:
 a. Before Water Injection Comparison Test
 (Baseline Sampler _____ % - Primary Sampler _____ %) = _____ %

Maximum Deviation From Table A.1 = _____ %

b. During Water Injection Test: (Wavg) = _____ %

Water Injection and Crude Volumes:

3. Water Injected (V)
 Stop Meter Totalizer _____ gal/l
 Start Meter Totalizer _____ gal/l
 V = Difference _____ gal/l x _____ x _____ = _____ bbls/m3
 (Meter Factor) (0.0238 gal/bbl or 0.001 l/m3)

4. Crude Volume
 Stop Tank or Meter Totalizer _____ bbl/m3
 Start Tank or Meter Totalizer _____ bbl/m3
 Difference _____ bbl/m3 x _____ = _____ bbls/m3
 (Meter Factor, as applicable)

5. TOV (line 3 + line 4) = _____ bbls/m3

CALCULATIONS:

Dev = (Wtest - Wbl) - Winj
 Where:
 Wtest = Percent water in test sample
 6. Wbl = Wavg x [(TOV - V) / TOV]
 = _____ x [(_____ - _____) / _____] = _____ %
 (line 1 or 2b) (line 5) (line 3) (line 5)

7. Winj = (V / TOV) x 100
 = (_____ / _____) x 100 = _____ %
 (line 3) (line 5)

Dev = (_____ - _____) - _____ = _____ %
 (Wtest) (line 6) (line 7)

Maximum Deviation From Table A.1 = _____ %

NOTES:

- All percent figures are % Volume.
- Correct the volume of water injected for solids content, as applicable, if production water is used.
- Deviations must be within limits outlined in MPMS Chapter 8.2, Table A.1.
- Note below any physical or procedural changes made between consecutive test runs.
- Attach copy of sampler receiver-mixer proving test report. See MPMS Chapter 8.3.

COMMENTS:

FIG. A6.1 Sampler Acceptance Test Data Sheet

APPENDIXES

(Nonmandatory Information)

X1. DESIGN DATA SHEET FOR AUTOMATIC SAMPLING SYSTEM

X1.1 Fig. X1.1 is a sample of the design data sheet for an automatic sampling system.

PROCESS DATA		DESIGN DATA	
Type of Product _____		Pipeline I.D. _____	
Specific Gravity or API _____		Design pressure _____	
Viscosity _____		Operating pressure _____	
Vapor Pressure _____		Other _____	
Expected water content (%) _____		Flow Rate _____	
H ₂ O (%) _____		Maximum _____ Minimum _____	
Other physical properties _____		Normal _____	
Sediment (%) _____		Parcel or batch size _____	
SAMPLER DATA		SAMPLE RECEIVER	
Grab size (ml/grab) _____		Total Volume _____	
Collection period: Hours ___ Days ___ Weeks ___		Design pressure _____	
Probe insertion length required _____		Design temperature _____	
Maximum grab rate required _____		Material of construction _____	
Air _____ (Pressure)		Internal coating _____	
Electricity _____ (Voltage)		Portable _____ Fixed _____	
Proportion to time _____, Flow _____		Accessories:	
Meter manufacturer _____		Pressure relief valve _____ (settings)	
Type _____		Vacuum relief _____ (settings)	
Signal _____		Pressure gauge _____ Level gauge _____	
Sampler Controller alarms: _____		Volume weight/indicator _____	
		Other _____	

SYSTEM SPECIFICATIONS			
INSTALLATION:		AVAILABLE UTILITIES:	
Permanent _____ Portable _____		Electrical: Voltage _____ Hz _____	
Electrical Classifications at proposed installation site _____		Phase _____	
		Air: Pressure _____ Instrument _____	
		Steam: Pressure _____ Temperature _____	
NOTES: _____			
COMPANY _____		PROJECT _____	
ADDRESS _____			
DATE PREPARED _____		DATE REQUIRED _____	

FIG. X1.1 Design Data Sheet for Automatic Sampling System

X2. COMPARISON OF PERCENT SEDIMENT AND WATER VERSUS UNLOADING TIME PERIOD

X2.1 Fig. X2.1 presents a comparison of percent sediment and water versus unloading time period.

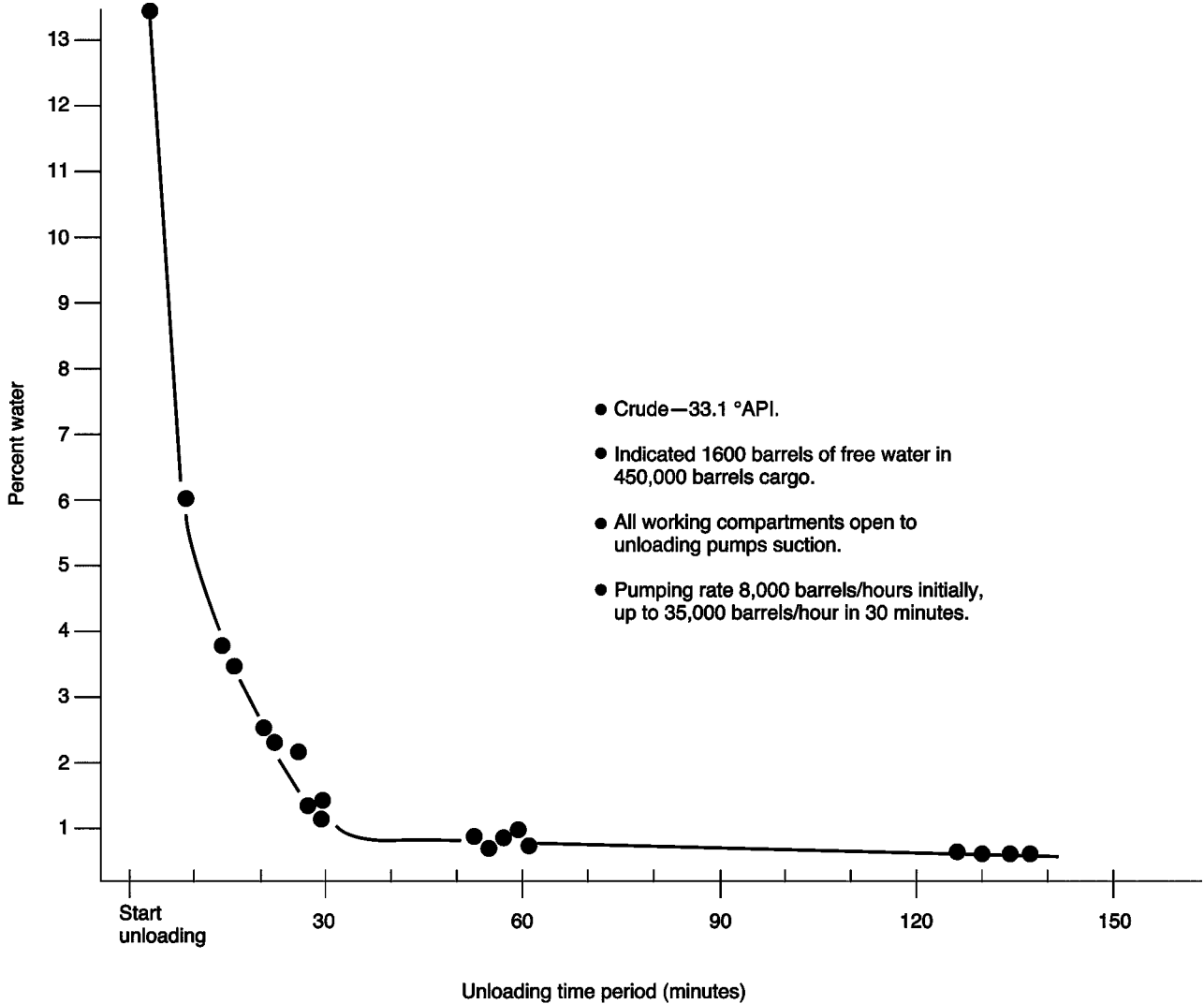

FIG. X2.1 Comparison of Percent Sediment and Water Versus Unloading Time Period

ASTM International takes no position respecting the validity of any patent rights asserted in connection with any item mentioned in this standard. Users of this standard are expressly advised that determination of the validity of any such patent rights, and the risk of infringement of such rights, are entirely their own responsibility.

This standard is subject to revision at any time by the responsible technical committee and must be reviewed every five years and if not revised, either reapproved or withdrawn. Your comments are invited either for revision of this standard or for additional standards and should be addressed to ASTM International Headquarters. Your comments will receive careful consideration at a meeting of the responsible technical committee, which you may attend. If you feel that your comments have not received a fair hearing you should make your views known to the ASTM Committee on Standards, at the address shown below.

This standard is copyrighted by ASTM International, 100 Barr Harbor Drive, PO Box C700, West Conshohocken, PA 19428-2959, United States. Individual reprints (single or multiple copies) of this standard may be obtained by contacting ASTM at the above address or at 610-832-9585 (phone), 610-832-9555 (fax), or service@astm.org (e-mail); or through the ASTM website (www.astm.org).