



Standard Test Method for Measuring Friction and Wear Properties of Lubricating Grease Using a High-Frequency, Linear-Oscillation (SRV) Test Machine¹

This standard is issued under the fixed designation D5707; the number immediately following the designation indicates the year of original adoption or, in the case of revision, the year of last revision. A number in parentheses indicates the year of last reapproval. A superscript epsilon (ϵ) indicates an editorial change since the last revision or reapproval.

1. Scope

1.1 This test method covers a procedure for determining a lubricating grease's coefficient of friction and its ability to protect against wear when subjected to high-frequency, linear-oscillation motion using an SRV test machine at a test load of 200 N, frequency of 50 Hz, stroke amplitude of 1.00 mm, duration of 2 h, and temperature within the range of the test machine, specifically, ambient to 280°C. Other test loads (10 to 1200 N for SRVI-model, 10 to 1400 N for SRVII-model, and 10 to 2000 N for SRVIII-model), frequencies (5 to 500 Hz) and stroke amplitudes (0.1 up to 4.0 mm) can be used, if specified. The precision of this test method is based on the stated parameters and test temperatures of 50 and 80°C. Average wear scar dimensions on ball and coefficient of friction are determined and reported.

NOTE 1—Optimol Instruments supplies an upgrade kit to allow SRVI/II-machines to operate with 1600 N, if needed.

1.2 This test method can also be used for determining a fluid lubricant's ability to protect against wear and its coefficient of friction under similar test conditions.

1.3 The values stated in SI units are to be regarded as standard. No other units of measurement are included in this standard.

1.4 *This standard does not purport to address all of the safety concerns, if any, associated with its use. It is the responsibility of the user of this standard to establish appropriate safety and health practices and determine the applicability of regulatory limitations prior to use.*

2. Referenced Documents

2.1 ASTM Standards:²

¹ This test method is under the jurisdiction of ASTM Committee D02 on Petroleum Products and Lubricants and is the direct responsibility of Subcommittee D02.G0.04 on Functional Tests - Tribology.

Current edition approved Nov. 1, 2005. Published January 2006. Originally approved in 1995. Last previous edition approved in 2003 as D5707-98(2003)^{ε1}. DOI: 10.1520/D5707-05.

² For referenced ASTM standards, visit the ASTM website, www.astm.org, or contact ASTM Customer Service at service@astm.org. For *Annual Book of ASTM Standards* volume information, refer to the standard's Document Summary page on the ASTM website.

[A295/A295M Specification for High-Carbon Anti-Friction Bearing Steel](#)

[D217 Test Methods for Cone Penetration of Lubricating Grease](#)

[D4175 Terminology Relating to Petroleum, Petroleum Products, and Lubricants](#)

[D5706 Test Method for Determining Extreme Pressure Properties of Lubricating Greases Using a High-Frequency, Linear-Oscillation \(SRV\) Test Machine](#)

[D6425 Test Method for Measuring Friction and Wear Properties of Extreme Pressure \(EP\) Lubricating Oils Using SRV Test Machine](#)

[E45 Test Methods for Determining the Inclusion Content of Steel](#)

[G40 Terminology Relating to Wear and Erosion](#)

2.2 Other Standards:³

[DIN EN ISO 683-17 Heat-treated Steels, alloy steels and free-cutting steels – Part 17 : Ball and roller bearing steels DIN 51834 , Part 3](#)

[DIN EN ISO 13565-2:1998 Geometrical Product Specifications \(GPS\) – Surface texture: Profile method; Surfaces having stratified functional properties – Part 2: Height characterization using linear material ratio curve \(replaces DIN 4776:1990: Measurement of surface roughness; parameters \$R_K\$, \$R_{PK}\$, \$R_{VK}\$, \$M_{r1}\$, \$M_{r2}\$ for the description of the material portion\)](#)

3. Terminology

3.1 Definitions:

3.1.1 *break-in, n—in tribology*, an initial transition process occurring in newly established wearing contacts, often accompanied by transients in coefficient of friction or wear rate, or both, which are uncharacteristic of the given tribological system's long-term behavior. **G40**

3.1.2 *coefficient of friction, n—in tribology*, the dimensionless ratio of the friction force (F) between two bodies to the normal force (N) pressing these bodies together. **G40**

3.1.3 *Hertzian contact area, n—the apparent area of contact between two nonconforming solid bodies pressed against each*

³ Available from Beuth Verlag GmbH, Burggrafenstrasse 6, D-10787 Berlin 30, Germany.

other, as calculated from Hertz's equations of elastic deformation. **G40**

3.1.4 *Hertzian contact pressure, n*—the magnitude of the pressure at any specified location in a Hertzian contact area, as calculated from Hertz's equations of elastic deformation. **G40**

3.1.5 *lubricant, n*—any material interposed between two surfaces that reduces the friction or wear between them. **D4175**

3.1.6 *lubricating grease, n*—a semifluid to solid product of a dispersion of a thickener in a liquid lubricant.

3.1.6.1 *Discussion*—The dispersion of the thickener forms a two-phase system and immobilizes the liquid lubricant by surface tension and other physical forces. Other ingredients are commonly included to impart special properties. **D217**

3.1.7 *Ra (C.L.A.), n*—measuring surface finish, the arithmetic average of the absolute distances of all profile points from the mean line for a given distance.⁴

3.1.7.1 *Discussion*—C.L.A. means center line average, and it is a synonym for Ra.

3.1.8 *Rpk, n*—reduced peak height according to **DIN EN ISO 13565-2:1998**. Rpk is the mean height of the peak sticking out above the core profile section.

3.1.9 *Rvk, n*—reduced valley height according to **DIN EN ISO 13565-2:1998**. Rvk is the mean depth of the valley reaching into the material below the core profile section.

3.1.10 *Ry, n*—in measuring surface finish, the vertical distance between the top of the highest peak and the bottom of the deepest valley in one sampling length of the roughness profile.⁵

3.1.11 *Rz (DIN), n*—in measuring surface finish, the average of all *Ry* values (peak to valley heights) in the assessment length.⁶

3.1.12 *SRV, n*—Schwingung, Reibung, Verschleiss, (German); oscillating, friction, wear, (English translation). **D5706**

3.1.13 *thickener, n*—in *lubricating grease*, a substance composed of finely divided particles dispersed in a liquid lubricant to form the product's structure.

3.1.13.1 *Discussion*—The thickener can be fibers (such as various metallic soaps) or plates or spheres (such as certain non-soap thickeners) which are insoluble or, at most, only very slightly soluble in the liquid lubricant. The general requirements are that the solid particles be extremely small, uniformly dispersed, and capable of forming a relatively stable, gel-like structure with the liquid lubricant. **D217**

3.1.14 *wear, n*—damage to a solid surface, generally involving progressive loss of material, due to the relative motion between that surface and a contacting substance or substances. **G40**

3.1.15 *Wv, n*—Wear volume is the loss of volume to the ball after a test. **D6425**

3.2 Definitions of Terms Specific to This Standard:

⁴ Amstutz, Hu, "Surface Texture: The Parameters," Bulletin MI-TP-003-0785, Sheffield Measurement Division, Warner and Swasey, 1985, p. 21.

⁵ Amstutz, Hu, "Surface Texture: The Parameters," Bulletin MI-TP-003-0785, Sheffield Measurement Division, Warner and Swasey, 1985, p. 25.

⁶ Amstutz, Hu, "Surface Texture: The Parameters," Bulletin MI-TP-003-0785, Sheffield Measurement Division, Warner and Swasey, 1985, pp. 31, 29.

3.2.1 *seizure, n*—localized fusion of metal between the rubbing surfaces of the test pieces.

3.2.1.1 *Discussion*—Seizure is usually indicated by a sharp increase in coefficient of friction, wear, or unusual noise and vibration. In this test method, increase in coefficient of friction is displayed on the chart recorder as a permanent rise in the coefficient of friction from a steady state value.

4. Summary of Test Method

4.1 This test method is performed on an SRV test machine using a test ball oscillated under constant load against a test disk.

NOTE 2—The frequency of oscillation, stroke length, test temperature, test load, and test ball and disk material can be varied from those specified in this test method. The test ball yields Hertzian point contact geometry. To obtain line or area contact, test pieces of differing configurations can be substituted for the test ball.

4.2 The wear scar on the test ball and coefficient of friction are measured. If a profilometer is available, a trace of the wear scar on the test disk can also be used to obtain additional wear information.

5. Significance and Use

5.1 This test method can be used to determine wear properties and coefficient of friction of lubricating greases at selected temperatures and loads specified for use in applications where high-speed vibrational or start-stop motions are present for extended periods of time under initial high Hertzian point contact pressures. This test method has found application in qualifying lubricating greases used in constant velocity joints of front-wheel-drive automobiles and for lubricating greases used in roller bearings. Users of this test method should determine whether results correlate with field performance or other applications.

6. Apparatus

6.1 *SRV Test Machine*,⁷ illustrated in **Figs. 1 and 2**.

6.2 *Microscope*, equipped with a filar eyepiece graduated in 0.005-mm division or equipped with a micrometer stage readable to 0.005 mm. Magnification should be sufficient to allow for ease of measurement. One to 10× magnification has been found acceptable.

7. Reagents and Materials

7.1 *Test Balls*⁷, 52100 steel, 60 ± 2 Rc hardness, 0.025 ± 0.005-µm *Ra* surface finish, 10-mm diameter.

7.2 *Lower Test Disk*,⁵ vacuum arc remelted (VAR) AISI 52100 steel with an inclusion rating using Method D, Type A, as severity level number of 0.5 according to Test Methods **E45** and Specification **A295/A295M** or an inclusion sum value $K1 \leq 10$ according to **DIN EN ISO 683-17** and spheroidized annealed to obtain globular carbide, 60 ± 2 Rc hardness, the surfaces of the disk being lapped and free of lapping raw

⁷ The sole source of supply of the apparatus known to the committee at this time is Optimol Instruments Prüftechnik GmbH, Friedenstrasse 10, D-81671 Munich, Germany. If you are aware of alternative suppliers, please provide this information to ASTM Headquarters. Your comments will receive careful consideration at a meeting of the responsible technical committee,¹ which you may attend.



FIG. 1 SRV Test Machine, Model III

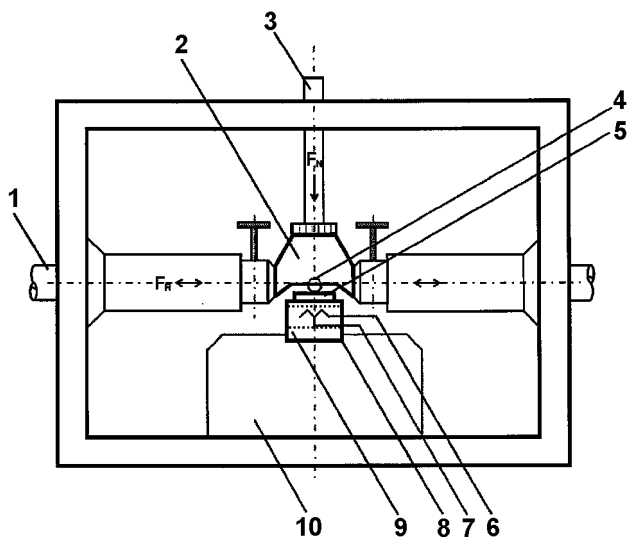

- | | |
|--------------------------|-----------------------------------|
| 1. Oscillation drive rod | 6. Electrical resistance heater |
| 2. Test ball holder | 7. Resistance thermometer |
| 3. Load rod | 8. Test disk holder |
| 4. Test ball | 9. Piezoelectric measuring device |
| 5. Test disk | 10. Receiving block |

FIG. 2 Test Chamber Elements

materials. The topography of the disk will be determined by four values, 24-mm diameter by 7.85 mm thick:

- $0.5 \mu\text{m} < R_z < 0.650 \mu\text{m}$
- $0.035 \mu\text{m} < \text{C.L.A. (Ra)} < 0.050 \mu\text{m}$
- $0.020 \mu\text{m} < R_{pk} < 0.035 \mu\text{m}$
- $0.050 \mu\text{m} < R_{vk} < 0.075 \mu\text{m}$

NOTE 3—The DIN 17230-1980 was replaced by [DIN EN ISO 683-17](#).

7.3 *n-Heptane*, reagent grade. (**Warning**—Flammable. Health hazard.)

7.4 *Isopropanol*, reagent grade. (**Warning**—Flammable. Health hazard.)

7.5 *Toluene*, reagent grade. (**Warning**—Flammable. Health hazard.)

7.6 *Cleaning Solvent*, a mixture of equal volumes of *n*-heptane, isopropanol, and toluene. (**Warning**—Flammable. Health hazard.)

8. Preparation of Apparatus

8.1 Turn on the test machine and chart recorder and allow to warm up for 15 min prior to running tests.

8.2 Select the friction data to be presented in the crest peak value position on the test apparatus in accordance with the manufacturer's directions.

NOTE 4—In most cases, this is accomplished by positioning the sliding switch on electronic card No. 291.35.20E (front side of electronics behind the front panel) and the sliding switch located on the back panel of the control unit.

8.3 Turn the amplitude knob to ZERO.

8.4 Switch the stroke adjustment to AUTO position.

8.5 Set the frequency to 50 Hz and duration to 2 h, 00 min, 30 s, in accordance with the manufacturer's instructions.

8.6 Set the desired span and calibrate the chart recorder in accordance with the manufacturer's instructions. Select the desired chart speed.

9. Procedure

9.1 Clean the test ball and disk by wiping the surfaces with laboratory tissue soaked with the cleaning solvent. Repeat wiping until no dark residue appears on the tissue. Immerse the specimen ball and disk in a beaker of the cleaning solvent under ultrasonic vibration for 10 min. Dry the test ball and disk with a clean tissue ensuring no streaking occurs on the surface.

9.2 Place a small amount (approximately 0.1 to 0.2 g, the size of a pea) of lubricating grease to be tested on the cleaned lower test disk in an area such that overlapping with previous wear scars will not occur.

9.3 Place the cleaned test ball on the top and in the middle of the lubricating grease specimen so that the grease makes a circular symmetric pad between the ball and disk.

9.4 Ensure the machine is unloaded (indicated by a load reading of -13 or -14 N) and carefully place the disk containing the lubricating grease specimen and test ball on the test area platform.

9.5 Tighten both the ball and disk clamps until resistance to tightening just begins. Load unit to 100 N and tighten the ball and disk clamps to a torque of 2.5 N·m. Reduce the load to 50 N for break-in.

9.6 Turn on the heater control and set to the desired temperature.

9.7 When temperature has stabilized, turn on the chart recorder paper feed, and lower the recording pens. Depress the drive start toggle switch until the timer begins to count and then adjust the stroke amplitude knob to 1.00 mm.

NOTE 5—Stroke should be checked periodically by measuring the wear track length minus the ball scar diameter. The difference must be smaller than $\pm 10\%$ of the set stroke.

9.8 When the digital timer reaches 30 s, increase the load to 200 N on the slow ramp speed setting and run at that load for $2 \text{ h} \pm 15 \text{ s}$. The test machine will automatically stop.

9.9 At the end of the test, turn off the heater control, turn power back on, and reduce the load to -13 or -14 N for disassembly.

NOTE 6—Power automatically turns off at the end of the test.

9.10 Remove and clean the test ball and disk in accordance with 9.1.

9.11 Place the test ball on a suitable holder and by means of a microscope, measure to the nearest 0.005 mm the minimum scar width and again at 90° to the first measurement. Measure the minimum coefficient of friction values from the chart recorder graph. Although not specifically part of the procedure, when additional wear analysis or the wear volume is required, perform a profilometric trace across the wear scar on the test disk in accordance with the profilometer manufacturer's instructions.

NOTE 7—Criteria for using the wear volume are stated in Test Method D6425-02 and for calculating the wear volume in DIN 51834, Part 3.

10. Report

10.1 Report the following information:

10.1.1 All parameters used to evaluate material as follows:

10.1.1.1 Test temperature, $^\circ\text{C}$,

10.1.1.2 Test break-in load, N,

10.1.1.3 Test load, N,

10.1.1.4 Test frequency, Hz,

10.1.1.5 Test stroke, mm,

10.1.1.6 Test ball material,

10.1.1.7 Test disk material, and

10.1.1.8 Test sample.

10.2 Report both wear scar measurements taken on the ball.

10.3 Report the minimum coefficient of friction and, when required by specification, include a copy of the friction recording.

10.4 Report the depth of the wear scar on the lower specimen disk if profilometer reading was made.

11. Precision and Bias

11.1 Eighteen cooperators tested eight greases in the SRV apparatus. Average minimum coefficients of friction ranged from 0.056 to 0.122 and average ball wear scar diameter ranged from 0.50 mm to 0.90 mm.^{8,9} These precision statements were originally published in D5707-95.

⁸ Supporting data have been filed at ASTM International Headquarters and may be obtained by requesting Research Report D02-1410.

⁹ Dickey, J., "New ASTM and DIN Methods for Measuring Tribological Properties using SRV Test Instrument," NLGI Spokesman, March 1997, pp. 17-23.

11.2 The precision of this test method, as determined by statistical examination of interlaboratory test results obtained at 200 N load, 50 Hz frequency, and 1 mm stroke at 50°C and 80°C is:

11.2.1 *Average Ball Wear Scar Diameter:*

11.2.1.1 *Repeatability*—The difference between successive results obtained by the same operator with the same apparatus under constant operating conditions on identical test material would, in the long run, in the normal and correct operation of the test method, exceed the following value only in one case in twenty.

0.07 mm

11.2.1.2 *Reproducibility*—The difference between two single and independent results obtained by different operators working in different laboratories on identical test method would, in the long run, exceed the following values only in one case in twenty.

For tests run at 50°C , 0.29 mm

For tests run at 80°C , 0.24 mm

11.2.2 *Minimum Coefficient of Friction:*

11.2.2.1 *Repeatability*—The difference between successive results obtained by the same operator with the same apparatus under constant operating condition on identical test material would, in the long run, in the normal and correct operation of the test method exceed the following values only in one case in twenty.

For tests run at 50°C , 0.012

For tests run at 80°C , 0.008

11.2.2.2 *Reproducibility*—The difference between two single and independent results obtained by different operators working in different laboratories on identical test materials would, in the long run, exceed the following values only in one case in twenty.

For tests run at 50°C , 0.031

For tests run at 80°C , 0.032

11.3 *Bias*—The evaluation of friction and wear properties of lubricating grease by this test method has no bias because coefficients of friction and wear scar diameter can be defined only in terms of the test method.

11.4 Using this ASTM test method for the corresponding DIN 51834, part 6, the DIN working group has conducted in 2000 and 2001 international round robin tests at 80°C with two greases. The results are given for information purposes in Table 1.¹⁰

12. Keywords

12.1 coefficient of friction; lubricating grease; oscillation; SRV; wear

¹⁰ Available from ASTM International Headquarters. Order Adjunct No. ADJD6300.

TABLE 1 Statistical Quantities of Different Greases in the International RR2000 and RR2001^A

Year	RR2001		RR2001		RR2000		RR2000	
Test greases	Li/Ca12OH stearat grease		PAO/Polybuten/ Bentonit		EP Calcium- Sulfonate-complex		ASTM G-2000-02 Lithium complex with MoS ₂ , Zn/S/P	
Statistical quantities	Coefficient of friction, f_{END}	Wear scar diameter of the ball, $W_{K-average}$, mm	Coefficient of friction, f_{END}	Wear scar diameter of the ball, $W_{K-average}$, mm	Coefficient of friction, f_{END}	Wear scar diameter of the ball, $W_{K-average}$, mm	Coefficient of friction, f_{END}	Wear scar diameter of the ball, $W_{K-average}$, mm
Degree of freedom	33	35	33	3 ¹	39	37	43	39
Mean	0.1175	0.5071	0.1162	0.5402	0.1222	0.44436	0.11116	0.49891
Standard deviation	± 0.0152	± 0.0284	± 0.0138	± 0.0387	± 0.0108	± 0.0476	± 0.0142	± 0.0344
Reproducibility, R	0.02	0.0817	0.0398	0.1116	0.0308	0.136	0.0406	0.0984
Repeatability, r	(set point: ≤ 0.032) 0.0107	(set point: ≤ 0.24) 0.0311	(set point: ≤ 0.032) 0.00854	(set point: ≤ 0.24) 0.0246	(set point: ≤ 0.032) 0.00903	(set point: ≤ 0.24) 0.0446	(set point: ≤ 0.032) 0.0161	(set point: ≤ 0.24) 0.00424
	(set point: ≤ 0.008)	(set point: ≤ 0.07)	(set point: ≤ 0.008)	(set point: ≤ 0.07)	(set point: ≤ 0.008)	(set point: ≤ 0.07)	(set point: ≤ 0.008)	(set point: ≤ 0.07)

^A RR2000 with 32 to 36 participants and RR2001 with 31 to 33 participants. The repeatability and the reproducibility were calculated using ADJD6300 (D2PP software). (Test conditions: $F_N = 200$ N; $T = 80^\circ\text{C}$; $t = 120$ min; $\Delta x = 1$ mm; $\nu = 50$ Hz; lapped AISI52100-disks; polished AISI52100-balls, $\varnothing = 10$ mm).

APPENDIX
(Nonmandatory Information)
X1. MEASUREMENTS OF COEFFICIENT OF FRICTION

X1.1 Other values of the coefficient of friction, in addition to the minimum value, can be read from the friction recording chart. An example of the recording and evaluation of friction coefficients, which appears in the German Standard SRV procedure DIN 51834, is shown in Fig. X1.1. In this procedure, the minimum and maximum coefficients and the average coefficient at 15, 30, and 90 min of the test are reported as is the ball wear scar diameter, W_K .

X1.1.1 The precision of friction and wear measurements according to DIN 51834-2:1997 or Test Method D6425-97 were refined in DIN 51834-2:2002 or Test Method D6425-02 is:

	Repeatability	Reproducibility
Quantity coefficient of Friction, f	0.01	0.03
Ball Wear Scar Diameter, w_K	0.07mm	0.2 mm

X1.1.1.1 These precision data DIN 51834-2:1997 or Test Method D6425-97 were obtained in an interlaboratory test program involving 22 laboratories and 3 lubricating oils, an antiwear hydraulic oil, an engine oil, and an EP gear oil.

X1.1.1.2 The current precision statements were taken from DIN 51834-2:2002 based on the international round robin tests 1997, 1998, 1999 and 2000 using FN= 300N, 1 mm of stroke, 0.03 ml of the lubricating oil and T= 50°C. These results were filed as new ASTM research report.

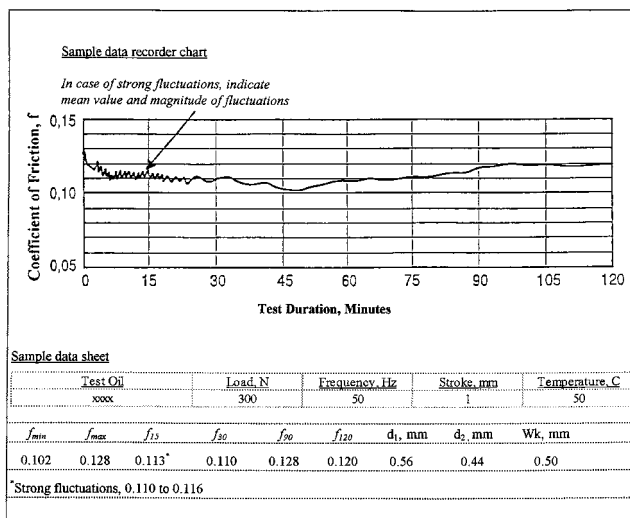

FIG. X1.1 Example: Sample Recording Chart and Data Sheet for Evaluating Coefficients of Friction and Wear Scar Diameters (taken from Test Method D6425-02)

ASTM International takes no position respecting the validity of any patent rights asserted in connection with any item mentioned in this standard. Users of this standard are expressly advised that determination of the validity of any such patent rights, and the risk of infringement of such rights, are entirely their own responsibility.

This standard is subject to revision at any time by the responsible technical committee and must be reviewed every five years and if not revised, either reapproved or withdrawn. Your comments are invited either for revision of this standard or for additional standards and should be addressed to ASTM International Headquarters. Your comments will receive careful consideration at a meeting of the responsible technical committee, which you may attend. If you feel that your comments have not received a fair hearing you should make your views known to the ASTM Committee on Standards, at the address shown below.

This standard is copyrighted by ASTM International, 100 Barr Harbor Drive, PO Box C700, West Conshohocken, PA 19428-2959, United States. Individual reprints (single or multiple copies) of this standard may be obtained by contacting ASTM at the above address or at 610-832-9585 (phone), 610-832-9555 (fax), or service@astm.org (e-mail); or through the ASTM website (www.astm.org). Permission rights to photocopy the standard may also be secured from the ASTM website (www.astm.org/COPYRIGHT/).