



# Standard Test Method for Nitrogen in Petroleum and Petroleum Products by Boat-Inlet Chemiluminescence<sup>1</sup>

This standard is issued under the fixed designation D5762; the number immediately following the designation indicates the year of original adoption or, in the case of revision, the year of last revision. A number in parentheses indicates the year of last reapproval. A superscript epsilon ( $\epsilon$ ) indicates an editorial change since the last revision or reapproval.

## 1. Scope\*

1.1 This test method covers the determination of nitrogen in liquid hydrocarbons, including petroleum process streams and lubricating oils in the concentration range from 40 to 10 000  $\mu\text{g/g}$  nitrogen. For light hydrocarbons containing less than 100  $\mu\text{g/g}$  nitrogen, Test Method [D4629](#) can be more appropriate.

1.2 The values stated in SI units are to be regarded as standard. No other units of measurement are included in this standard.

1.3 *This standard does not purport to address all of the safety concerns, if any, associated with its use. It is the responsibility of the user of this standard to establish appropriate safety and health practices and determine the applicability of regulatory limitations prior to use.* Specific warning statements are given in Section [6](#), [7.1](#), [8.2](#), and [8.2.2](#).

## 2. Referenced Documents

### 2.1 ASTM Standards:<sup>2</sup>

[D4057](#) Practice for Manual Sampling of Petroleum and Petroleum Products

[D4177](#) Practice for Automatic Sampling of Petroleum and Petroleum Products

[D4629](#) Test Method for Trace Nitrogen in Liquid Petroleum Hydrocarbons by Syringe/Inlet Oxidative Combustion and Chemiluminescence Detection

[D6299](#) Practice for Applying Statistical Quality Assurance and Control Charting Techniques to Evaluate Analytical Measurement System Performance

## 3. Summary of Test Method

3.1 A hydrocarbon sample is placed on a sample boat at room temperature. The sample and boat are advanced into a

<sup>1</sup> This test method is under the jurisdiction of ASTM Committee [D02](#) on Petroleum Products and Lubricants and is the direct responsibility of Subcommittee [D02.03](#) on Elemental Analysis.

Current edition approved April 15, 2009. Published May 2009. Originally approved in 1995. Last previous edition approved in 2008 as D5762–08. DOI: 10.1520/D5762-09.

<sup>2</sup> For referenced ASTM standards, visit the ASTM website, [www.astm.org](http://www.astm.org), or contact ASTM Customer Service at [service@astm.org](mailto:service@astm.org). For *Annual Book of ASTM Standards* volume information, refer to the standard's Document Summary page on the ASTM website.

high-temperature combustion tube where the nitrogen is oxidized to nitric oxide (NO) in an oxygen atmosphere. The NO contacts ozone and is converted to excited nitrogen dioxide (NO<sub>2</sub>). The light emitted as the excited NO<sub>2</sub> decays is detected by a photomultiplier tube, and the resulting signal is a measure of the nitrogen contained in the sample.

## 4. Significance and Use

4.1 Many nitrogen compounds can contaminate refinery catalysts. They tend to be the most difficult class of compounds to hydrogenate, so the nitrogen content remaining in the product of a hydrotreater is a measure of the effectiveness of the hydrotreating process. In lubricating oils the concentration of nitrogen is a measure of the presence of nitrogen containing additives. This test method is intended for use in plant control and in research.

## 5. Apparatus

5.1 *Boat Inlet System*, capable of being sealed to the inlet of the combustion tube and swept with inert gas. The boats are fabricated from platinum or quartz. To aid quantitative liquid injection, it is recommended to add a small piece of quartz wool or suitable equivalent (see [6.8](#)) to the boat. The boat drive mechanism should be able to fully insert the boat into the furnace tube inlet section. A drive mechanism that advances and withdraws the sample boat into and out of the furnace at a controlled and repeatable rate is required.

5.2 *Chemiluminescence Detector*, capable of measuring light emitted from the reaction between nitric oxide and ozone, and containing a variable attenuation amplifier, integrator, and readout.

NOTE 1—Detectors designed to maintain the chemiluminescence reaction cell at reduced pressure are acceptable for use and were included in the instruments used to determine the precision of this test method.

5.3 *Combustion Tube*, fabricated from quartz. The inlet end of the tube shall be large enough to accept the sample boat and to have side arms for introduction of oxygen and inert gas. The construction is such that the carrier gases sweep the inlet zone transporting all of the volatilized sample into a high-temperature oxidation zone. The oxidation section should be large enough to ensure complete oxidation of the sample.

\*A Summary of Changes section appears at the end of this standard.

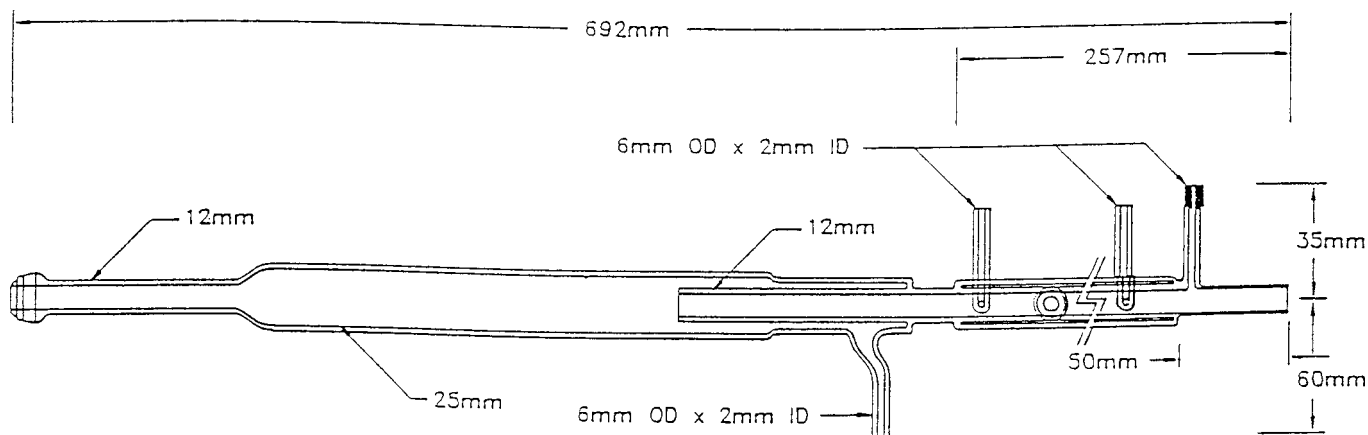

FIG. 1 Quartz Combustion Tube (Single-Zone Furnace)

Combustion tubes recommended for the two furnaces in 5.5.1 and 5.5.2 are described in 5.3.1 and 5.3.2. Other configurations are acceptable if precision and bias are not degraded.

5.3.1 Quartz combustion tube for use with the single-zone furnace is illustrated in Fig. 1. A water-jacket around the inlet section can be used to cool the boat prior to sample injection.

5.3.2 Quartz combustion tube for use with the two-zone furnace is illustrated in Fig. 2. Fig. 3 illustrates a combustion tube for a two-zone furnace that is equipped with the ability to switch to a pure oxygen carrier gas flow after the boat has been fully extended into the furnace (consult the instrument manual to determine if the instrument changes to a pure oxygen carrier gas flow after the boat is inserted). The outlet end of the pyrolysis tube is constructed to hold a removable quartz insert tube. The removable quartz insert tube is packed with an oxidation catalyst as recommended by the instrument manufacturer.

5.4 *Drier Tube*, for the removal of water vapor. The reaction products include water vapor that shall be eliminated prior to measurement by the detector. This can be accomplished with a magnesium perchlorate,  $Mg(ClO_4)_2$ , scrubber, a membrane drying tube permeation drier, or a chilled dehumidifier assembly.

5.5 *Furnace, Electric*, held at a temperature sufficient to pyrolyze all of the sample and oxidize the nitrogen to NO. The following furnace designs may be used. All furnace assemblies include a method for gas flow control, such as needle valves, flow restrictors or mass flow controllers. Furnaces that are operated at temperatures below  $1050^\circ C$  shall be capable of switching to 100% oxygen carrier gas flow after the boat has been fully extended into the furnace.

5.5.1 Single-zone tube furnace with temperature controller capable of maintaining a stable furnace temperature of  $1100 \pm 25^\circ C$ .

5.5.2 Two-zone tube furnace with temperature controllers capable of maintaining the temperature of each furnace zone independently from  $950$  to  $1050^\circ C$  (see 5.5). Or two-zone tube furnace equipped with the ability to change to a pure oxygen carrier gas flow after the boat is fully extended in to the furnace and temperature controllers capable of maintaining the temperature of each furnace zone independently to  $950^\circ C$ .

5.6 *Microlitre Syringe*, of 5 or 10- $\mu L$  capacity, capable of accurately delivering microlitre quantities.

5.7 *Ozone Generator*, to supply ozone to the detector reaction cell.

5.8 *Recorder (Optional)*, for display of chemiluminescence detector signal.

## 6. Reagents and Materials

6.1 *Purity of Reagents*—Reagent grade chemicals shall be used in all tests. Unless otherwise indicated, it is intended that all reagents shall conform to the specifications of the Committee on Analytical Reagents of the American Chemical Society where such specifications are available.<sup>3</sup> Other grades may be used, provided it is first ascertained that the reagent is of sufficiently high purity to permit its use without lessening the accuracy of the determination.

6.2 *Acridine*,  $C_{13}H_9N$ , molecular weight 179.21, 7.82 mass % nitrogen. (**Warning**—Irritant.)

6.3 *Oxidation Catalyst: Cupric Oxide Wire, CuO, or Platinum Catalyst, PtAl<sub>2</sub>O<sub>3</sub>*, as recommended by the instrument manufacturer.

6.4 *Inert Gas*—Argon or Helium only, high-purity grade (that is, chromatographic or zero grade), 99.998 % minimum purity, 5 ppm maximum moisture.

6.5 *Anhydrous Magnesium Perchlorate*,  $Mg(ClO_4)_2$ , for drying products of combustion (if permeation drier or chilled drier is not used). (**Warning**—Strong oxidizer, irritant.)

6.6 *Nitrogen Stock Solution, 500 ng nitrogen/ $\mu L$* —Accurately weigh (to the nearest 0.1 mg) approximately 0.64 g of acridine into a tared 100-mL volumetric flask. Add xylene to dissolve, then dilute to volume with xylene. Calculate the nitrogen content of the stock solution to the nearest milligram of nitrogen per litre. This stock can be further diluted to desired

<sup>3</sup> *Reagent Chemicals, American Chemical Society Specifications*, American Chemical Society, Washington, DC. For suggestions on the testing of reagents not listed by the American Chemical Society, see *Analar Standards for Laboratory Chemicals*, BDH Ltd., Poole, Dorset, U.K., and the *United States Pharmacopeia and National Formulary*, U.S. Pharmacopeial Convention, Inc. (USPC), Rockville, MD.

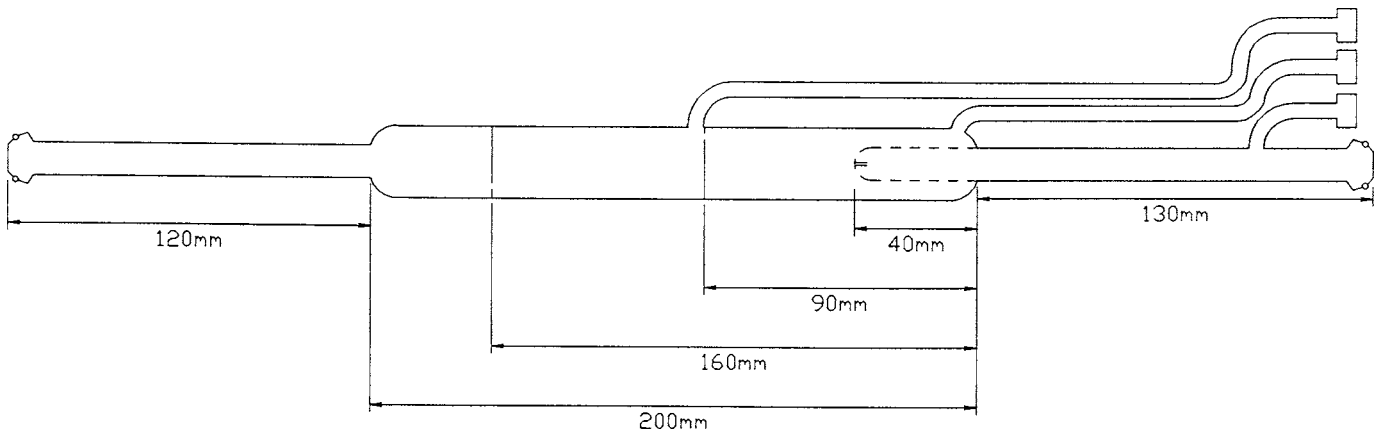

FIG. 2 Quartz Combustion Tube (Two-Zone Furnace)

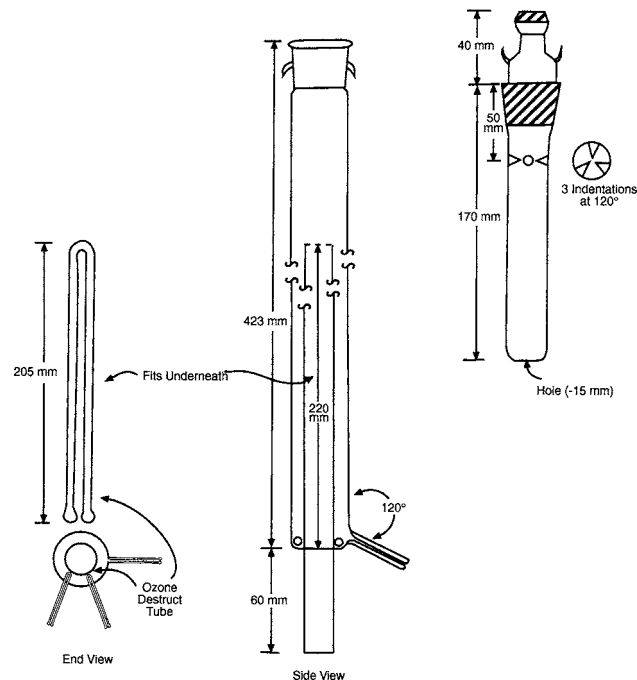

FIG. 3 Quartz Combustion Tube (for two zone furnace equipped with the ability to switch to pure oxygen carrier gas flow)

nitrogen concentrations. (**Warning**—Remake standard solutions on a regular basis depending upon frequency of use and age. Typically, standards have a useful life of approximately three months.)

6.7 *Oxygen*, high-purity grade (that is, chromatographic or zero grade), 99.75 % minimum purity, 5 ppm maximum moisture, dried over molecular sieves. (**Warning**—Vigorously accelerates combustion.)

6.8 *Quartz Wool* (optional), or other suitable absorbent material that is stable and capable of withstanding temperatures inside the furnace (see **Note 2**).

**NOTE 2**—Materials meeting the requirements in 6.8 are recommended to be used in sample boats to provide a more uniform injection of the sample into the boat by wicking any remaining drops of the sample from the tip of the syringe needle prior to introduction of the sample into the

furnace. Consult instrument manufacturer recommendations for further guidance.

6.9 *Silver Wool*, as recommended by the instrument manufacturer.

6.10 *Xylene*. (**Warning**—Flammable, health hazard.)

6.11 *Calibration Check Sample(s)*—portions of one or more liquid petroleum or product standards of known nitrogen content and not used in the generation of the calibration curve. A calibration check sample or samples shall be used to verify the validity of the calibration curve as described in Section 10.

6.12 *Quality Control (QC) Sample(s)*—preferably portions of one or more liquid petroleum materials that are stable and representative of the samples of interest. These QC samples can be used to verify that the testing process is in statistical control as described in Section 10.

## 7. Sampling

7.1 Obtain a test sample in accordance with Practice D4057 or D4177. (**Warning**—Samples that are collected at temperatures below room temperature can undergo expansion at laboratory temperatures and rupture the container. For such samples, do not fill the container to the top. Leave sufficient air space above the sample to allow room for expansion.) (**Warning**—To minimize loss of volatile components, which can be present in some test samples, do not uncover any longer than necessary. Test samples should be analyzed as soon as possible after taking from bulk supplies to prevent loss of nitrogen or contamination due to exposure or contact with sample container.)

7.2 If the test sample is not used immediately, then thoroughly mix it in its container prior to taking a test specimen. Some test samples require heating in order to thoroughly homogenize.

## 8. Preparation of Apparatus

8.1 Assemble apparatus in accordance with the manufacturer's instructions.

8.2 Adjust the oxygen flow for the ozone generator in accordance with the manufacturer's instructions. Adjust the combustion tube gas flows and the pyrolysis temperature to the recommended operating conditions using the following guidelines for each furnace type. (**Warning**—Ozone is extremely toxic. Make sure that appropriate steps are taken to prevent discharge of ozone within the laboratory work area.)

8.2.1 For the single-zone furnace without the ability to change to a pure oxygen carrier gas flow after the boat has been fully extended into the furnace, adjust the combustion tube gas flows to the following values: pyrolysis oxygen,  $360 \pm 36$  mL/min; inlet oxygen,  $60 \pm 6$  mL/min; and inert carrier inlet,  $155 \pm 15$  mL/min. Other gas flows may be used if it can be shown that precision and bias are not degraded. Set the furnace temperature to  $1100 \pm 25^\circ\text{C}$ . Adjust the boat drive mechanism to obtain a drive rate of  $150 \pm 10$  mm/min. Refer to the manufacturer's instructions for descriptions of these settings.

8.2.2 For the two-zone furnace without the ability to change to a pure oxygen carrier gas flow after the boat has been fully extended into the furnace, adjust the combustion tube gas flows to the following values: combustion oxygen,  $165 \pm 16$  mL/min; inlet inert carrier,  $85 \pm 9$  mL/min; and boat inert carrier,  $50 \pm 5$  mL/min. Other gas flows may be used if it can be shown that precision and bias are not degraded. Set the inlet furnace temperature to  $1050 \pm 25^\circ\text{C}$ , and the outlet furnace temperature to  $925 \pm 25^\circ\text{C}$ . Adjust the boat drive mechanism to obtain a drive rate of  $150 \pm 10$  mm/min (boat speed number 4). Refer to the manufacturer's instructions for the description of these settings. (**Warning**—High temperature is employed in this test method. Use flammable materials with care near the pyrolysis furnace.)

8.2.3 For the two-zone furnace with the ability to change to a pure oxygen carrier gas flow after the boat has been fully extended into the furnace, adjust the combustion tube gas flows to the following values: main oxygen,  $400 \pm 40$  mL/min; inlet argon carrier,  $0.4 \pm 0.04$  L/min, and inlet oxygen carrier,  $0.4 \pm 0.04$  L/min. Other gas flows may be used if it can be

shown that precision and bias are not degraded. Set the inlet furnace temperature to  $600 \pm 25^\circ\text{C}$ , and the outlet (catalyst) temperature to  $950 \pm 25^\circ\text{C}$ . Set the automatic boat control as follows: 1 Fuc FWD 125 speed 10 time 30, 2 Fuc 285 speed 05 time 30, 5 Fuc time 30, 6 Fuc time 90, A Fuc time 60. Refer to manufacturer's instructions for a description of these settings.

8.3 Insert boat into furnace for a minimum of 2 min to remove any residual nitrogen species.

## 9. Calibration and Standardization

9.1 Prepare calibration standards containing 1, 5, 10, 50, and 100 ng nitrogen/ $\mu\text{L}$  in xylene by volumetric dilution of the 500-ng nitrogen/ $\mu\text{L}$  nitrogen stock solution.

9.2 Five microlitres of the material to be analyzed (see Note 3) shall be quantitatively placed in the sample boat for measurement of chemiluminescence response. There are two alternative injection procedures available, the volumetric and the gravimetric procedures.

NOTE 3—The formation of NO and NO<sub>2</sub> from oxidative combustion of nitrogen containing hydrocarbons is dependent on combustion conditions such as temperature and oxygen concentration. Injection of a constant solution volume, and dilution of all test specimens and standards with a common solvent, maintain consistent combustion conditions for test specimens and standards.

9.2.1 For volumetric measurement of the material by microlitre syringe, flush the microlitre syringe several times with the material, discarding the flushed liquid each time. Fill the 10- $\mu\text{L}$  syringe to the 5- $\mu\text{L}$  level. Retract the plunger so that the lower liquid meniscus falls on the 10 % scale mark. When bubbles are present within the liquid column, flush the syringe and withdraw a new aliquot of the liquid. Record the volume of liquid in the syringe. Immediately inject the liquid into the boat, being careful to displace the last drop by touching the edge of the boat, or the quartz wool or suitable equivalent (see 6.8) if present, with the syringe needle. After the injection, again retract the plunger so that the lower liquid meniscus falls on the 10 % scale mark and record the volume of liquid in the syringe. The difference between the two volume readings is the volume of liquid injected.

NOTE 4—An automatic sampling and injection device can be used in place of the described manual injection procedure.

9.2.2 For gravimetric measurement of the solution, fill the syringe as indicated in 9.2.1. Weigh the microlitre syringe and its contents, and record the mass to the nearest 0.01 mg. Immediately inject the liquid into the boat, being careful to displace the last drop by touching the edge of the boat, or the quartz wool or suitable equivalent (see 6.8) if present, with the syringe needle. After the injection, remove the syringe and again weigh the syringe and its contents. Record the mass to the nearest 0.01 mg. The difference between the two weighings is the mass of liquid injected. The gravimetric procedure is more precise than the volumetric procedure, provided a balance with a precision of  $\pm 0.01$  mg is used.

9.3 Activate the boat drive mechanism to insert the boat into the furnace. The instrument baseline should remain stable until the boat approaches the furnace and volatilization of injected material begins. After the measurement is complete, retract the boat. The instrument baseline should reestablish before the



boat has completely emerged from the furnace. Record the integrated chemiluminescence response. Allow the boat to cool for at least 1 min before the next injection.

9.4 Calibrate the instrument using one of the following two techniques.

9.4.1 Perform measurements for the calibration standards and blank using the procedure described in 9.2 and 9.3. Measure the calibration standards and blank three times each, and determine the average integrated chemiluminescence response for each. Construct a curve plotting average integrated detector response (y-axis) versus nanograms of nitrogen injected (x-axis).

9.4.2 If the system features an internal calibration routine, measure the calibration standards and blank three times each using the procedure described in 9.2 and 9.3. Calibrate the analyzer in accordance with the manufacturer's instructions using the average of the three measurements for each standard and blank.

9.5 If analyzer calibration is performed using only a subset of the calibration standards listed in 9.1, the calibration standards closest in concentration to the measured solution(s) must be included in the subset (that is, if the concentration of the test specimen solution is 20 ng nitrogen/ $\mu\text{L}$ , include the 10 and 50-ng nitrogen/ $\mu\text{L}$  standards in the calibration). System performance must be checked with the calibration standards at least once per day.

## 10. Quality Control (QC)

10.1 *Calibration Check Sample(s)*—A sample of known nitrogen content will be run after each calibration. The sample can also be analyzed periodically throughout a series of analyses to check the functioning of the instrument and the validity of the calibration curve. This sample can be a National Institute for Standards and Technology Standard Reference Material (SRM) material, an acridine in xylene standard prepared to have a nitrogen value not used to calibrate the instrument, or any other material that has been analyzed repeatedly such that sufficient data are available to determine a statistical mean. The results of the analysis of the known sample will be within 10 % of the certified or accepted value for the operation and calibration of the instrument to be considered acceptable. If the results are not within 10 % of the accepted value, perform appropriate corrective maintenance on the instrument and repeat the calibration procedure described in 9.4.

10.2 *QC Samples*—Confirm the performance of the instrument or the test procedure by analyzing a QC sample (6.12).

10.2.1 When QC / Quality Assurance (QA) protocols are already established in the testing facility, they may be used when they confirm the reliability of the test result.

10.2.2 When there is no QC / QA protocol established in the testing facility, Appendix X1 can be used as the QC / QA system.

## 11. Procedure

11.1 Obtain a test specimen using the procedure described in Section 7. Prepare a test specimen solution by dilution of the test specimen in xylene. Use a dilution factor of at least 1:5 (see Note 3). The nitrogen concentration in the test specimen

solution shall be less than the concentration of the highest standard used in calibration and greater than 3 ng nitrogen/ $\mu\text{L}$ . The dilution can be performed either on a weight or volume basis.

11.1.1 For gravimetric dilution, record the mass of the test specimen and the total mass of the test specimen and solvent.

11.1.2 For volumetric dilution, record the mass of the test specimen and the total volume of the test specimen and solvent.

11.2 Measure the chemiluminescence response for the test specimen solution using the procedure described in 9.2 and 9.3.

11.3 If the chemiluminescence response from the test specimen solution is greater than the response from the highest calibration standard used, repeat the test specimen dilution described in 11.1 using a higher dilution factor. Repeat the analysis procedure described in 9.2 through 9.3 on this new test specimen solution.

11.4 Inspect the boat and combustion tube to verify complete combustion of the test specimen solution. Increase the residence time for the boat in the furnace if coke or soot is observed on the boat. Decrease the boat drive introduction rate if coke or soot is observed on the exit end of the combustion tube. Clean any coked or sooted parts. After any cleaning or adjustment, repeat instrument calibration prior to reanalysis of the test specimen.

11.5 Measure each test specimen solution three times and calculate the average chemiluminescence response.

## 12. Calculation

12.1 For analyzers calibrated using a standard curve, calculate the nitrogen content of the test specimen in micrograms per gram ( $\mu\text{g/g}$ ) as follows:

$$\text{Nitrogen, } (\mu\text{g/g}) = \frac{(I - Y)}{S \times M \times K_g} \quad (1)$$

or,

$$\text{Nitrogen, } (\mu\text{g/g}) = \frac{(I - Y)}{S \times V \times K_v} \quad (2)$$

where:

$D$  = density of test specimen solution, g/mL,

$I$  = average of integrated detector response for test specimen solution, counts (or found ng nitrogen),

$K_g$  = gravimetric dilution factor, mass of test specimen/mass of test specimen and solvent, g/g,

$K_v$  = volumetric dilution factor, mass of test specimen/volume of test specimen and solvent, g/mL,

$M$  = mass of test specimen solution injected, either measured directly or calculated from measured volume injected and density,  $V \times D$ , mg,

$S$  = slope of standard curve, counts/ng nitrogen (or found ng nitrogen/ng nitrogen),

$V$  = volume of test specimen solution injected, either measured directly or calculated from measured mass injected and density,  $M/D$ ,  $\mu\text{L}$ , and

$Y$  = y-intercept of standard curve, counts (or found ng nitrogen).

12.2 For analyzers calibrated using an internal calibration routine, calculate the nitrogen content of the test specimen in micrograms/gram ( $\mu\text{g/g}$ ) as follows:

$$\text{Nitrogen, } (\mu\text{g/g}) = \frac{I}{M \times K_g} \quad (3)$$

or,

$$\text{Nitrogen, } (\mu\text{g/g}) = \frac{I}{V \times K_v} \quad (4)$$

where:

- $D$  = density of test specimen solution, g/mL,  
 $I$  = average of visual display readings of test specimen solution, ng nitrogen,  
 $K_g$  = gravimetric dilution factor, mass of test specimen/mass of test specimen and solvent, g/g,  
 $K_v$  = volumetric dilution factor, mass of test specimen/volume of test specimen and solvent, g/mL,  
 $M$  = mass of test specimen solution injected, either measured directly or calculated from measured volume injected and density,  $V \times D$ , mg, and  
 $V$  = volume of test specimen solution injected, either measured directly or calculated from measured mass injected and density,  $M/D$ ,  $\mu\text{L}$ .

### 13. Report

13.1 Report nitrogen results to two significant figures. State that results were obtained in accordance with Test Method D5762.

### 14. Precision and Bias <sup>4</sup>

14.1 *Repeatability*—The difference between two test results obtained by the same operator with the same apparatus under constant operating conditions on identical test material would, in the long run, in the normal and correct operation of the test method, exceed the following values in only one case in twenty, where  $X$  = the average of the two test results.

$$r = 0.087 \times X \mu\text{g/g} \quad (5)$$

14.2 *Reproducibility*—The difference between two single and independent results obtained by different operators working in different laboratories on identical test material would, in the long run, in the normal and correct operation of the test method, exceed the following values in only one case in twenty, where  $X$  = the average of the two test results.

$$R = 0.266 \times X \mu\text{g/g} \quad (6)$$

14.3 *Bias*—A NIST SRM was analyzed by the cooperators participating in the repeatability and reproducibility determination. This test method showed no significant bias for this sample within the repeatability of this test method.

### 15. Keywords

15.1 chemiluminescence; nitrogen

---

<sup>4</sup> Supporting data have been filed at ASTM International Headquarters and may be obtained by requesting D02-1370 and D02-1507.

## APPENDIX

### (Nonmandatory Information)

#### X1. QUALITY CONTROL (QC) MONITORING

X1.1 Confirm the performance of the instrument or the test procedure by analyzing QC sample(s).

X1.2 Prior to monitoring the measurement process, the user of this test method needs to determine the average value and control limits of the QC sample. (See Practice D6299 and MNL7.<sup>5</sup>)

X1.3 Record the QC results and analyze by control charts or other statistically equivalent techniques to ascertain the statistical control status of the total testing process. In the absence of explicit requirements given in the test method, this clause provides guidance on QC testing frequency. (See Practice D6299 and MNL7.<sup>5</sup>) Investigate any out-of-control data for root cause(s). The results of this investigation may, but not necessarily, result in instrument recalibration.

X1.4 The frequency of QC testing is dependent on the criticality of the quality being measured, the demonstrated stability of the testing process, and customer requirements. Generally, a QC sample should be analyzed each testing day with routine samples. The QC frequency should be increased if a large number of samples are routinely analyzed. However, when it is demonstrated that the testing is under statistical control, the QC testing frequency may be reduced. The QC sample testing precision should be periodically checked against the ASTM test method precision to ensure data quality. (See Practice D6299 and MNL7.<sup>5</sup>)

X1.5 It is recommended that, if possible, the type of QC sample that is regularly tested be representative of the material routinely analyzed. An ample supply of QC sample material should be available for the intended period of use, and it shall be homogenous and stable under the anticipated storage conditions.

X1.6 See Practice D6299 and MNL7<sup>5</sup> for further guidance on QC and control charting techniques.

---

<sup>5</sup> MNL7, *Manual on Presentation of Data Control Chart Analysis*, 6th ed., Section 3, ASTM International, W. Conshohocken, PA.

## SUMMARY OF CHANGES

Subcommittee D02.03 has identified the location of selected changes to this standard since the last issue (D5762–08) that may impact the use of this standard.

(I) Added Report, Section **13**.

*ASTM International takes no position respecting the validity of any patent rights asserted in connection with any item mentioned in this standard. Users of this standard are expressly advised that determination of the validity of any such patent rights, and the risk of infringement of such rights, are entirely their own responsibility.*

*This standard is subject to revision at any time by the responsible technical committee and must be reviewed every five years and if not revised, either reapproved or withdrawn. Your comments are invited either for revision of this standard or for additional standards and should be addressed to ASTM International Headquarters. Your comments will receive careful consideration at a meeting of the responsible technical committee, which you may attend. If you feel that your comments have not received a fair hearing you should make your views known to the ASTM Committee on Standards, at the address shown below.*

*This standard is copyrighted by ASTM International, 100 Barr Harbor Drive, PO Box C700, West Conshohocken, PA 19428-2959, United States. Individual reprints (single or multiple copies) of this standard may be obtained by contacting ASTM at the above address or at 610-832-9585 (phone), 610-832-9555 (fax), or [service@astm.org](mailto:service@astm.org) (e-mail); or through the ASTM website ([www.astm.org](http://www.astm.org)). Permission rights to photocopy the standard may also be secured from the ASTM website ([www.astm.org](http://www.astm.org)/COPYRIGHT/).*