



Standard Test Method for Oil Separation from Lubricating Grease (Conical Sieve Method)¹

This standard is issued under the fixed designation D6184; the number immediately following the designation indicates the year of original adoption or, in the case of revision, the year of last revision. A number in parentheses indicates the year of last reapproval. A superscript epsilon (ϵ) indicates an editorial change since the last revision or reapproval.

INTRODUCTION

The conical sieve method for measuring leakage from lubricating grease (commonly known as the cone bleed test) is virtually the same as Federal Test Method (FTM) 791C Method 321.3, Oil Separation from Lubricating Grease (Static Technique). Despite the lack of a precision statement, Method 321.3 has been used for many years in military and industrial grease specifications to determine fluid separation tendencies. Test Method D6184 overcomes the deficiencies of Method 321.3. It reflects the procedures and precision determinations used in a cooperative study in Subcommittee D02.G0 of Committee D02 and is intended to supersede the FTM method.

1. Scope

1.1 This test method covers the determination of the tendency of lubricating grease to separate oil at an elevated temperature. This test method shall be conducted at 100°C for 30 h unless other conditions are required by the grease specification.

1.2 This test method is not suitable for greases having a penetration (Test Methods **D217**) greater than 340 (softer than NLGI No. 1 grade).

1.3 The values stated in SI units are to be regarded as standard. No other units of measurement are included in this standard.

1.4 *This standard does not purport to address all the safety concerns, if any, associated with its use. It is the responsibility of the user of this standard to establish appropriate safety practices and determine the applicability of regulatory limitations prior to use.*

2. Referenced Documents

2.1 *ASTM Standards:*²

D217 Test Methods for Cone Penetration of Lubricating Grease

D1742 Test Method for Oil Separation from Lubricating

¹ This test method is under the jurisdiction of ASTM Committee **D02** on Petroleum Products and Lubricants and is the direct responsibility of Subcommittee **D02.G0** on Lubricating Grease.

Current edition approved Nov. 1, 2005. Published November 2005. Originally approved in 1997. Last previous edition approved in 1998 as D6184 – 98. DOI: 10.1520/D6184-98R05.

² For referenced ASTM standards, visit the ASTM website, www.astm.org, or contact ASTM Customer Service at service@astm.org. For *Annual Book of ASTM Standards* volume information, refer to the standard's Document Summary page on the ASTM website.

Grease During Storage

E437 Specification for Industrial Wire Cloth and Screens (Square Opening Series)³

2.2 *Government Standard:*

Federal Test Method (FTM) 791C Method 321.3, Oil Separation from Lubricating Greases (Static Method)⁴

3. Terminology

3.1 *Definitions:*

3.1.1 *lubricating grease, n*—a semifluid to solid product of a dispersion of a thickener in a liquid lubricant.

3.1.1.1 *Discussion*—The dispersion of the thickener forms a two-phase system and immobilizes the liquid lubricant by surface tension and other physical forces. Other ingredients imparting special properties are often included. **D217**

3.1.2 *oil separation, n*—the appearance of a liquid fraction from an otherwise homogeneous lubricating composition. **D1742**

3.1.3 *thickener, n*—in a lubricating grease, a substance composed of finely divided particles dispersed in a liquid lubricant to form the product's structure.

3.1.3.1 *Discussion*—The thickener can be fibers (such as various metallic soaps) or plates or spheres (such as certain non-soap thickeners) which are insoluble or, at most, only very slightly soluble in the liquid lubricant. The general requirements are that the solid particles be extremely small, uniformly dispersed, and capable of forming a relatively stable, gel-like structure with the liquid lubricant **D217**

³ Withdrawn. The last approved version of this historical standard is referenced on www.astm.org.

⁴ Available from Standardization Documents Order Desk, Bldg. 4 Section D, 700 Robbins Ave., Philadelphia, PA 19111-5094, Attn: NPODS.

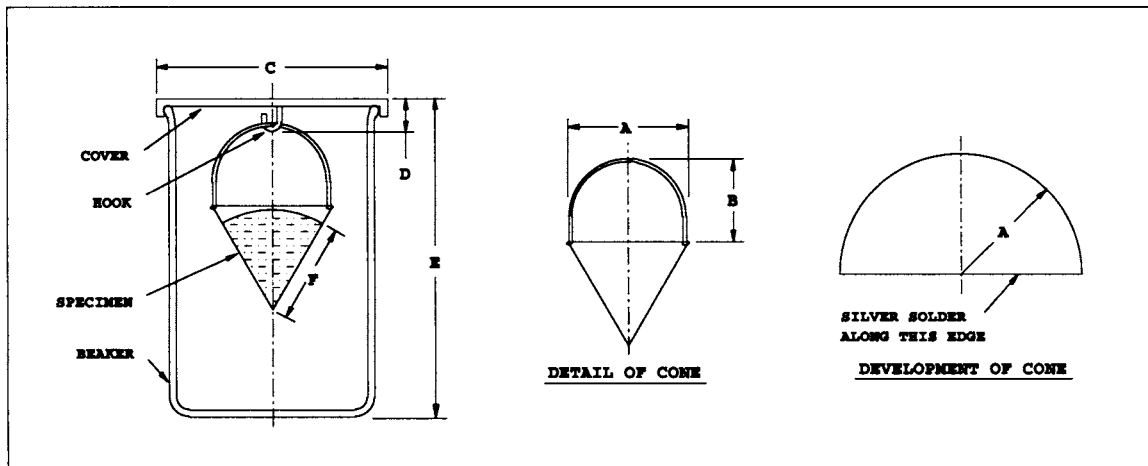

NOTE 1—Dimensions are provided in millimetres (with in./lb. units in parentheses) as follows:

A – 38.1 ± 0.3	(1.50 ± 0.01)	radius
B – 27.0 ± 0.3	(1.06 ± 0.01)	height
C – 70	(2.8)	approximately (to fit beaker)
D – 9.7 ± 3.3	(0.38 ± 0.13)	length
E – 100	(4)	approximately
F – 36	(1.4)	approximately

FIG. 1 Cone Fabrication and Test Setup

4. Summary of Test Method

4.1 The weighed sample is placed in a cone-shaped, wire-cloth sieve, suspended in a beaker, then heated under static conditions for the specified time and temperature. Unless otherwise required by the grease specification, the sample is tested at standard conditions of $100 \pm 0.5^\circ\text{C}$ for 30 ± 0.25 h. The separated oil is weighed and reported as a percentage of the mass of the starting test sample.

5. Significance and Use

5.1 When a lubricating grease separates oil, the residual material changes in consistency, which can affect the ability of the product to function as designed. Test results obtained with this procedure are intended to correlate with oil separation that occurs in 35-lb pails of grease during storage. They are not intended to predict oil separation tendencies of grease under dynamic service conditions.

NOTE 1—No quantitative relationship between results and oil separation in 35-lb pails has been developed.

5.2 This test method is used for specifications and quality control.

NOTE 2—No data have been developed to compare results between this test method and Test Method D1742.

6. Apparatus

6.1 *Test Apparatus*—The assembled apparatus consists of a cone-shaped sieve constructed of 60-mesh, corrosion-resistant wire cloth, a 200-mL tall-form beaker without spout, and a closely fitting cover with a hook in the center. Construction details and dimensions are shown in Fig. 1.

6.1.1 The conical sieve shall be fabricated of stainless steel, monel, or nickel wire cloth, of No. 60 medium-heavy mesh as

defined in Table 2 of Specification E437 and shall be fabricated to the dimensions and requirements shown in Fig. 1.

NOTE 3—Sieves of stapled or wire-bound construction, instead of silver-soldered construction, have been used in the past. Such sieves do not conform to this test method.

6.2 *Oven*, capable of maintaining the specified temperature, $100 \pm 0.5^\circ\text{C}$.

6.3 *Balance*, having a minimum capacity of 250 g and a sensitivity of at least 0.01 g.

7. Sampling

7.1 Examine the sample for any indication of non-homogeneity such as oil separation, phase changes, or gross contamination. If any abnormal conditions are found, obtain a new sample.

7.2 The sample submitted for analysis should be minimally sufficient for duplicate testing.

7.3 Although the mass of the test grease is determined, the sieve is filled by volume rather than mass. Each test will require a quantity sufficient to fill the sieve to approximately the same level as indicated in Fig. 1 (about 10 mL). Approximately the same volume shall be used for each test regardless of the grease density; the mass will range from about 8 to 12 g.

8. Preparation of Apparatus

8.1 Carefully clean the sieve, beaker, and cover, by wiping with a suitable solvent. Allow the sieve to air dry. See Note 4.

NOTE 4—Use of an ultrasonic solvent bath has been found helpful in cleaning the sieve.

8.2 Inspect the sieve to make certain that it is clean and free of deposits that could affect the passage of oil. It shall be free

of any screen irregularities such as tears, dents, creases, or enlarged or diminished openings.

9. Procedure

9.1 Preheat the oven to test temperature. Unless otherwise specified, the test shall be conducted at standard conditions of $100 \pm 0.5^\circ\text{C}$ for 30 ± 0.25 h.

9.2 Weigh the beaker to within 0.01 g, W_i .

9.3 Tare the assembled apparatus consisting of the sieve, cover, and beaker as shown in Fig. 1 to the nearest 0.01 g.

9.4 With a suitable spatula, fill the cone sieve with sufficient grease to approximate the level shown in Fig. 1, being careful to avoid inclusion of air. Exercise care not to force grease through the screen. Smooth and shape the top of the grease into a slightly convex surface to prevent trapping free oil.

9.5 Assemble the entire apparatus as shown in Fig. 1, and weigh to the nearest 0.01 g. Calculate the mass of the grease by difference, G .

9.6 Place the assembled apparatus in the oven for the specified time and temperature.

9.7 Remove the apparatus from the oven and cool to room temperature. Remove the cone from the beaker, tapping it gently against the inside of the beaker to take off any oil adhering to its tip. Weigh the beaker containing the collected oil to the nearest 0.01 g, W_f .

9.8 Soon after completion of the test, clean the apparatus (Section 8) in preparation for subsequent testing.

10. Calculation

10.1 Calculate the oil separation as the percentage separated from the original sample as follows:

$$\text{oil separation, \%} = \frac{W_f - W_i}{G} \times 100 \quad (1)$$

where:

W_i = mass of the beaker before heating,

W_f = mass of the beaker after heating, and

G = mass of the grease tested.

11. Report

11.1 Report the following information:

11.1.1 Grease identity,

11.1.2 Test date,

11.1.3 Test temperature and duration, and

11.1.4 Oil separation, nearest 0.1 %.

TABLE 1 Precision Values for Several Oil Separation Percentages

Oil Separation, %	Repeatability	Reproducibility
1	1.15	1.51
5	2.57	3.39
10	3.64	4.79
20	5.15	6.78

12. Precision and Bias

12.1 *Precision*—Eight cooperators tested eight greases for leakage in a cooperative program conducted in accordance with the design-of-experiments described in RR:D02-1007.⁵ All tests were run in duplicate. The total range of results were from 0.1 to 23.7 % leakage (see Table 1).

12.2 The precision of the percent oil separation as determined by this test method was obtained in accordance with ADJ6300 (D2PP software).⁶

12.3 The repeatability and reproducibility of the test method as determined by statistical examination of the interlaboratory results are as follows:

12.3.1 *Repeatability*—The difference between two test results, obtained by the same operator with the same apparatus under constant specified operating conditions on identical test material would, in the long run, in the normal and correct operation of the test method, exceed the following values only in 1 case in 20:

$$\text{repeatability, \% oil separation} = 1.151 \times (M)^{0.5} \quad (2)$$

where:

M = mean of two determinations.

12.3.2 *Reproducibility*—The difference between two single and independent results by two different operators working in different laboratories on identical test material would, in the long run, in the normal and correct operation of the test method, exceed the following values only in 1 case in 20:

$$\text{reproducibility, \% oil separation} = 1.517 \times (M)^{0.5} \quad (3)$$

where

M = mean of two determinations.

12.4 *Bias*—The procedure for measuring the oil separation from lubricating grease has no bias because the value of the oil loss is defined only in terms of this test method.

13. Keywords

13.1 cone-bleed test; leakage; lubricating grease; oil bleed; oil separation

⁵ Supporting data have been filed at ASTM International Headquarters and may be obtained by requesting Research Report RR:D02-1007.

⁶ Available from ASTM International Headquarters. Order Adjunct No. ADJ6300.

ASTM International takes no position respecting the validity of any patent rights asserted in connection with any item mentioned in this standard. Users of this standard are expressly advised that determination of the validity of any such patent rights, and the risk of infringement of such rights, are entirely their own responsibility.

This standard is subject to revision at any time by the responsible technical committee and must be reviewed every five years and if not revised, either reapproved or withdrawn. Your comments are invited either for revision of this standard or for additional standards and should be addressed to ASTM International Headquarters. Your comments will receive careful consideration at a meeting of the responsible technical committee, which you may attend. If you feel that your comments have not received a fair hearing you should make your views known to the ASTM Committee on Standards, at the address shown below.

This standard is copyrighted by ASTM International, 100 Barr Harbor Drive, PO Box C700, West Conshohocken, PA 19428-2959, United States. Individual reprints (single or multiple copies) of this standard may be obtained by contacting ASTM at the above address or at 610-832-9585 (phone), 610-832-9555 (fax), or service@astm.org (e-mail); or through the ASTM website (www.astm.org). Permission rights to photocopy the standard may also be secured from the ASTM website (www.astm.org/COPYRIGHT/).