



Standard Test Method for Determination of Corrosion-Preventive Properties of Lubricating Greases Under Dynamic Wet Conditions (Emcor Test)¹

This standard is issued under the fixed designation D6138; the number immediately following the designation indicates the year of original adoption or, in the case of revision, the year of last revision. A number in parentheses indicates the year of last reapproval. A superscript epsilon (ϵ) indicates an editorial change since the last revision or reapproval.

1. Scope*

1.1 This test method covers the determination of corrosion-preventive properties of greases using grease-lubricated ball bearings under dynamic wet conditions.

1.2 The values stated in SI units are to be regarded as standard. No other units of measurement are included in this standard.

1.3 *This standard does not purport to address all of the safety concerns, if any, associated with its use. It is the responsibility of the user of this standard to establish appropriate safety and health practices and determine the applicability of regulatory limitations prior to use.*

2. Referenced Documents

2.1 *ASTM Standards:*²

D217 Test Methods for Cone Penetration of Lubricating Grease

D665 Test Method for Rust-Preventing Characteristics of Inhibited Mineral Oil in the Presence of Water

D1193 Specification for Reagent Water

2.2 *ISO Standards:*³

ISO 15 Rolling bearings - Radial bearings - Boundary dimensions - General plan

ISO 3696 Water for analytical laboratory use - Specifications and test methods

ISO 7120 Petroleum products and lubricants - Petroleum oils and other fluids - Determination of rust-preventing characteristics in the presence of water

3. Terminology

3.1 *Definitions:*

3.1.1 *lubricating grease, n*—a semifluid to solid product of a thickener in a liquid lubricant.

3.1.1.1 *Discussion*—The dispersion of the thickener forms a two-phase system and immobilizes the liquid lubricant by surface tension and other physical forces. Other ingredients are commonly included to impart special properties. **D217**

3.1.2 *thickener, n*—*in lubricating grease*, a substance composed of finely-divided particles dispersed in a liquid lubricant to form the product's structure.

3.1.2.1 *Discussion*—The thickeners can be fibers (such as various metallic soaps) or plates or spheres (such as certain non-soap thickener), which are insoluble or, at most, only very slightly soluble in the liquid lubricant. The general requirements are that the solid particles be extremely small, uniformly dispersed, and capable of forming a relatively stable, gel-like structure with the liquid lubricant. **D217**

3.2 *Definitions of Terms Specific to This Standard:*

3.2.1 *corrosion, n*—red rust or black spots on the race.

3.2.1.1 *Discussion*—any stain through which the underlying metal surface is still visible shall be ignored.

4. Summary of Test Method

4.1 New, cleaned, and lubricated bearings are tested partially immersed in water (distilled, synthetic sea water, or sodium chloride solution) under no applied load at a speed of 83 ± 5 rpm in a predetermined sequence of running and stopping for a period of approximately one week. After

¹ This test method is under the jurisdiction of ASTM Committee D02 on Petroleum Products and Lubricants and is the direct responsibility of Subcommittee D02.G0.06 on Functional Tests - Contamination.

Current edition approved July 1, 2007. Published August 2007. Originally approved in 1997. Last previous edition approved in 2003 as D6138-03. DOI: 10.1520/D6138-07.

² For referenced ASTM standards, visit the ASTM website, www.astm.org, or contact ASTM Customer Service at service@astm.org. For *Annual Book of ASTM Standards* volume information, refer to the standard's Document Summary page on the ASTM website.

³ Available from American National Standards Institute (ANSI), 25 W. 43rd St., 4th Floor, New York, NY 10036, http://www.ansi.org.

*A Summary of Changes section appears at the end of this standard.

cleaning, the bearing rings are examined and rated according to the degree of corrosion.

5. Significance and Use

5.1 This test method is used to assess the ability of grease to prevent corrosion in rolling bearings operated in the presence of distilled water, sodium chloride solution, or synthetic sea water. It is used for development and specification purposes.

6. Apparatus

6.1 *Test Bearings*—Use a double row self-aligning ball bearing (30 by 72 by 19 mm), conforming to 1306 K of **ISO 15**, with a steel cage.⁴ In cases of dispute, the SKF bearing specified in Footnote 5 shall be used as the referee bearing.

6.2 *SKF TMG/Emcor Test Machine*, see Annex A1 for description.

6.3 *Dentist's Mirror*, non-magnifying.

6.4 *Graduated Pipette or Syringe*, capable of measuring 20 ± 1 mL water.

6.5 *Oven*, capable of maintaining $90 \pm 2^\circ\text{C}$.

7. Reagents

7.1 *Purity of Reagents*—Reagent grade chemicals shall be used in all tests. Unless otherwise indicated, it is intended that all reagents shall conform to the specifications of the Committee on Analytical Reagents of the American Chemical Society, where such specifications are available.⁵ Other grades may be used, provided it is first ascertained that the reagent is of sufficiently high purity to permit its use without lessening the accuracy of the determination.

7.2 *Purity of Water*—Unless otherwise indicated, references to water shall be understood to mean reagent water as defined by Grade 2 of **ISO 3696**.

7.3 *Synthetic Sea Water*—If required, as specified in Specification **D665**, and **ISO 7120**.

7.4 *Sodium Chloride Solution*—a 0.5-mol/L solution of sodium chloride prepared using water conforming to Grade 2 of **ISO 3696**, at a pH of 8.0 to 8.2 adjusted by titration with sodium hydroxide solution.

NOTE 1—Other water types, such as that specified in Specification **D1193**, Type III, can be used in this test method, although the precision when using other water types has not been determined. It is recommended that the pH of the other water types is determined before use.

7.5 *Isopropyl Alcohol*—(**Warning**—Flammable. Poison. Causes burns. Vapor extremely irritating. May be fatal if swallowed. Harmful if inhaled.)

7.6 *Ammonium Hydroxide*—(**Warning**—Flammable. Poison. Causes burns. Vapor extremely irritating. May be fatal if swallowed. Harmful if inhaled.)

7.7 *Solvent Rinse Solution*, of the following composition by volume:

7.7.1 90 % Isopropyl alcohol.

7.7.2 9 % Distilled water.

7.7.3 1 % Ammonium hydroxide, 3.2-mol/L concentration. (**Warning**—Flammable. Poison. Causes burns. Vapor extremely irritating. May be fatal if swallowed. Harmful if inhaled.)

7.8 *Mineral Spirit*, also known as Stoddard Solvent, reagent grade. (**Warning**—Combustible. Vapor Harmful.)

8. Preparation of Bearings

8.1 Examine the test bearings carefully and select only bearings that have outer rings and balls entirely free of corrosion. During the bearing preparation, handle the bearings with tongs or protective gloves. Do not touch the bearings with bare fingers at any time. Use two new bearings for each grease being tested.

8.2 Number bearings on the outside diameter of the outer ring, but do not use chemical etching. One method to number the bearings is with an electric pen, which should be grounded on the outer ring surface being marked.

8.3 Wash the selected bearings thoroughly in hot (50 to 65°C) mineral spirits (**Warning**—see 7.8) to remove the rust preventive. To ensure complete removal, subject the bearing to a second wash in fresh hot mineral spirits. (**Warning**—The washing temperatures specified are considerably above the flash point of the solvent. Accordingly, the washing operation should be carried out in a well-ventilated hood where no ignition source is present.)

8.4 Transfer bearings to the solvent rinse solution (**Warning**—see 7.7.3) to remove any mineral spirits which may be present. Rinse each bearing and slowly rotate one ring relative to the other ring in fresh hot ($65 \pm 5^\circ\text{C}$) solvent rinse solution. Fresh rinse solution is used to avoid the selective evaporation of the components at the rinse temperature.

NOTE 2—Care must be taken when handling bearings in the hot rinse solution to avoid burns. Tongs and heat resistant gloves are recommended.

8.5 Remove each bearing from the solvent rinse solution and place on filter paper to drain. After draining, dry the bearing in an oven at $90 \pm 2^\circ\text{C}$ for 15 to 30 min.

8.6 Permit the bearing to cool to room temperature and reexamine the surfaces to ensure that corrosion-free bearings have been selected. (Exercise care when handling the bearing to avoid rotating one ring relative to the other ring after cleaning and drying.)

8.6.1 Inspect the outer ring tracks. (**Fig. 1** illustrates the area to be inspected.) If etch spots or corrosion are evident, reject the bearing. A dentist's mirror can be helpful for inspection purposes.

9. Procedure

9.1 Prepare the apparatus by removing all traces of grease from the previous tests by wiping the plummer blocks. Wash the plummer blocks with the solvent rinse solution followed by water. Dry thoroughly using a lint-free cloth.

9.2 Distribute $10 \text{ g} \pm 0.1 \text{ g}$ of the grease evenly in each test bearing using a spatula or bearing packer. Take care to avoid

⁴ 1306 K steel caged bearing manufactured by NTN and DKF may be used; however, precision had only been evaluated using SKF 1306 K/236 725 bearings.

⁵ *Reagent Chemicals, American Chemical Society Specifications*, American Chemical Society, Washington, DC. For suggestions on the testing of reagents not listed by the American Chemical Society, see *Analar Standards for Laboratory Chemicals*, BDH Ltd., Poole, Dorset, U.K., and the *United States Pharmacopeia and National Formulary*, U.S. Pharmacopeial Convention, Inc. (USPC), Rockville, MD.

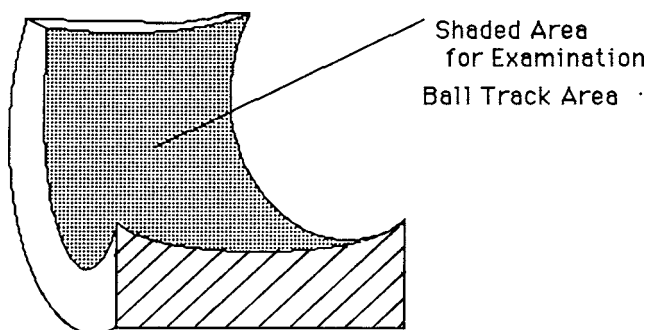

FIG. 1 Partial Outer Ring of Double-Row Self-Aligning Bearing

the inclusion of air bubbles. Rotate the outer ring slightly with a gloved hand to assist distribution. Smear all the external surfaces of the bearing with additional grease.

9.3 Prepare two bearings for each grease to be tested. Each pair of bearings is used for one test.

9.4 Place the adapter sleeves, bearings, and V-ring seals in position on the shaft and finger-tighten the sleeve nuts.

9.5 Place the shaft complete with greased bearings in position in the test rig, taking care that the bearings are centered in the plummer blocks.

9.6 Place the top halves of the plummer block in position and finger-tighten the locking screws.

9.7 Press the V-ring seals up against the plummer blocks using the special tool supplied with the test machine.

9.8 Run the test rig for 30 ± 5 min at 83 ± 5 rpm immediately after assembly to distribute the grease evenly.

9.9 Without delay, remove the top halves of the plummer blocks and introduce 10 mL of distilled water, synthetic sea water or sodium chloride solution into each side of each plummer block (a total of 20 ± 1 mL) using a pipette or syringe. Refit top halves of plummer blocks and finger-tighten the locking screws.

NOTE 3—Although the test can be run with other user-defined solutions, the precision limits described in Section 12 apply only to tests conducted with reagents described in Section 7.

9.10 Without delay, operate the test rig according to the following schedule:

9.10.1 Run $8 \text{ h} \pm 10 \text{ min}$, stop, allow to stand $16 \text{ h} \pm 10 \text{ min}$;

9.10.2 Run $8 \text{ h} \pm 10 \text{ min}$, stop, allow to stand $16 \text{ h} \pm 10 \text{ min}$;

9.10.3 Run $8 \text{ h} \pm 10 \text{ min}$, stop, allow to stand $108 \text{ h} \pm 2 \text{ h}$.

9.11 Immediately following the time schedule (9.10), remove the top halves of the plummer blocks. Lift the shaft and bearings on to a suitable support on the work bench. Unscrew the sleeve nuts one or two revolutions. Tap the bearings lightly to free them, then pull bearings, sleeves, and seals off the shaft.

9.12 Dismantle the bearings for inspection by prying balls out of the cage pockets until the outer ring can be removed.

9.13 Wash the outer rings in the solvent rinse solution and dry, using a lint-free cloth. Examine immediately.

10. Rating Procedure

10.1 Visually examine the outer ring track area for rust or etch spots, without the aid of any optical adjuncts, and evaluate

TABLE 1 Corrosion Classifications

NOTE—Under certain circumstances a pair of parallel bands may be observed, the color of which changes with viewing angle; do not confuse these bands with corrosion which appears black when viewed from all angles.

Rating	Designation	Description
0	no corrosion	no corrosion
1	trace	no more than three spots of corrosion, none of which has a diameter larger than 1 mm
2	light	small areas of corrosion covering up to 1 % of the surface
3	moderate	areas of corrosion covering between 1 and 5 % of the surface
4	heavy	areas of corrosion covering between 5 and 10 % of the surface
5	severe	areas of corrosion covering more than 10 % of the surface

as described in Table 1. Fig. 1 illustrates the area to be examined. Fig. 2 illustrates examples intended to assist in the assessment of the degree of corrosion. Ignore any staining through which the underlying metal surface is clearly visible.

11. Report

11.1 Report the degree of corrosion and the type of water solution used for the test in accordance with one of the classifications and descriptions in Table 1. If the two ratings agree within the precision given for repeatability, report the two figures, otherwise make two further determinations.

NOTE 4—To assist in estimating percentage corrosion area, a transparent grid divided into suitable squares can be used.

12. Precision and Bias

12.1 Precision—The precision of this test method, as determined by statistical examination of interlaboratory results, is as follows:

12.1.1 Repeatability—The difference between successive test results, obtained by the same operator with the same apparatus under constant operating conditions on identical test material, in the normal and correct operation of the test method, would exceed the values shown in Table 2 only in one case in twenty.

12.1.2 Reproducibility—The difference between two single and independent results, obtained by different operators working in different laboratories on nominally identical test material, in the normal and correct operation of the test method, would exceed the values shown in Table 2 only in one case in twenty.

NOTE 5—The precision is based on that adopted by the ISO committee from the IP Precision Evaluation Panel reports issued on June 27, 1979 and January 28, 1980, for the IP 220 round robin performed in 1965. A copy of these reports is available from ASTM Headquarters.⁶

12.2 Bias—The procedure for determining the corrosion preventive properties of grease has no bias because the value of corrosion is defined only in terms of this test method.

⁶ Supporting data have been filed at ASTM International Headquarters and may be obtained by requesting Research Report D02-1417.

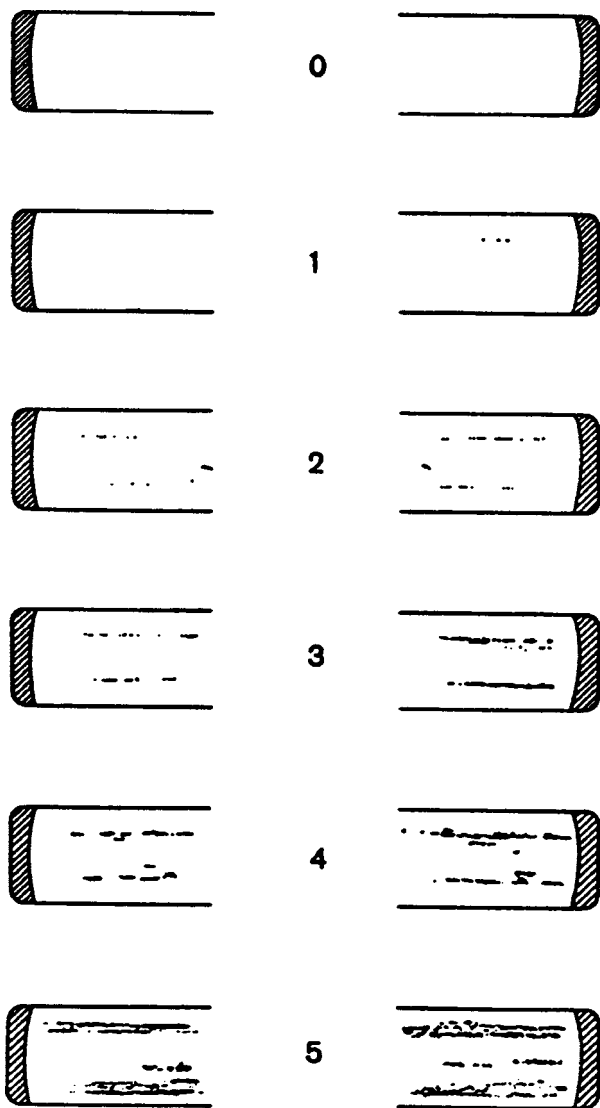

FIG. 2 Various Ratings Illustrating Degree of Corrosion

TABLE 2 Precision Values

Test Fluid	Repeatability	Reproducibility
Water as specified in 7.2	1	1
Synthetic sea water as specified in 7.3	1	2
Sodium chloride solution as specified in 7.4	1	2

13. Keywords

13.1 corrosion; Emcor test; lubricating grease; rust

ANNEX

(Mandatory Information)

A1. APPARATUS

A1.1 *Dynamic Antirust Test Rigs*—Fig. A1.1 shows part of a standard rig (Drawing No. SKF 1516600) which is capable of accommodating up to eight self-aligning ball bearings fitted with adapter sleeves and sleeve nuts (3) of polyamide plastic. The bearings (2) are located in plummer blocks (1) (SKF SN 507) which, in the standard rig are polyamide plastic, according to drawing number SKF 720315. The rig is mounted on a mechanical plate (6), approximately 275 by 985 mm by 10 mm. The shaft (4), 25 mm in diameter, is coated with polyamide plastic. Two V-ring seals (5) per plummer block are

required, together with a tool (7) for correct positioning of the seals.⁷

A1.2 *Electric Motor*—Use any suitable type of electric motor. The motor shall be fitted with reduction gear and flexible coupling to drive the shaft directly at 83 ± 5 rpm.

⁷ The SKF designation is an example of suitable products available commercially. The SKF drawing is available from SKF USA, Inc., 1100 First Ave, King of Prussia, PA 19406.

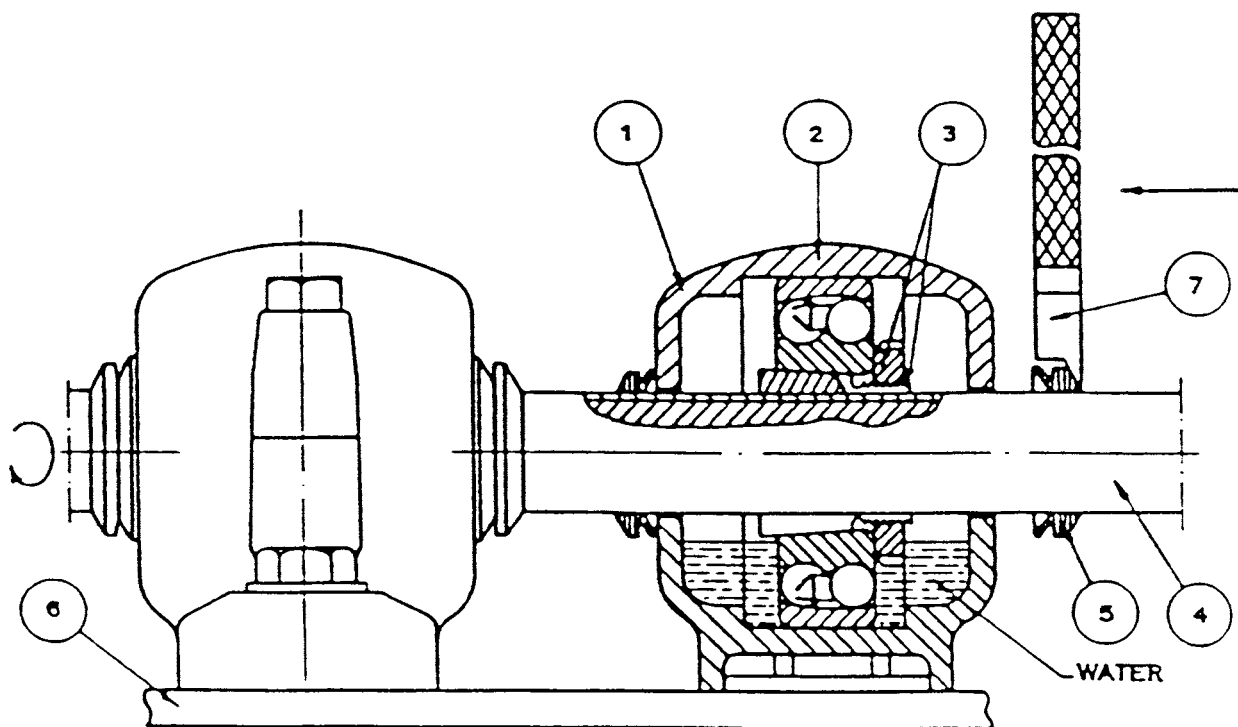

FIG. A1.1 Suitable Test Rig

A1.3 *General*—A stand to hold the shaft on the work bench is also required and an automatic timing device is recommended.

SUMMARY OF CHANGES

Subcommittee D02.G0 has identified the location of selected changes to this standard since the last issue (D6138–03) that may impact the use of this standard.

(1) Revised 6.4, 9.2, and 9.9.

(2) Added Note 3.

ASTM International takes no position respecting the validity of any patent rights asserted in connection with any item mentioned in this standard. Users of this standard are expressly advised that determination of the validity of any such patent rights, and the risk of infringement of such rights, are entirely their own responsibility.

This standard is subject to revision at any time by the responsible technical committee and must be reviewed every five years and if not revised, either reapproved or withdrawn. Your comments are invited either for revision of this standard or for additional standards and should be addressed to ASTM International Headquarters. Your comments will receive careful consideration at a meeting of the responsible technical committee, which you may attend. If you feel that your comments have not received a fair hearing you should make your views known to the ASTM Committee on Standards, at the address shown below.

This standard is copyrighted by ASTM International, 100 Barr Harbor Drive, PO Box C700, West Conshohocken, PA 19428-2959, United States. Individual reprints (single or multiple copies) of this standard may be obtained by contacting ASTM at the above address or at 610-832-9585 (phone), 610-832-9555 (fax), or service@astm.org (e-mail); or through the ASTM website (www.astm.org).