



Standard Test Method for Determining Extreme Pressure Properties of Solid Bonded Films Using a High-Frequency, Linear-Oscillation (SRV) Test Machine¹

This standard is issued under the fixed designation D7217; the number immediately following the designation indicates the year of original adoption or, in the case of revision, the year of last revision. A number in parentheses indicates the year of last reapproval. A superscript epsilon (ϵ) indicates an editorial change since the last revision or reapproval.

1. Scope

1.1 This test method covers a procedure for determining extreme pressure properties of solid bonded films under high-frequency linear-oscillation motion using the SRV test machine.

1.2 The values stated in SI units are to be regarded as standard. No other units of measurement are included in this standard.

1.3 *This standard does not purport to address all of the safety concerns, if any, associated with its use. It is the responsibility of the user of this standard to establish appropriate safety and health practices and determine the applicability of regulatory limitations prior to use.*

2. Referenced Documents

2.1 ASTM Standards:²

A295/A295M Specification for High-Carbon Anti-Friction Bearing Steel

D2510 Test Method for Adhesion of Solid Film Lubricants

D4175 Terminology Relating to Petroleum, Petroleum Products, and Lubricants

E45 Test Methods for Determining the Inclusion Content of Steel

G40 Terminology Relating to Wear and Erosion

2.2 Other Standards:

DIN EN ISO 683-17 Heat-treated Steels, Alloy Steels and Free-Cutting Steels—Part 17: Ball and Roller Bearing Steels³

DIN EN ISO 13565-2:1998 Geometrical Product Specifications (GPS)—Surface Texture: Profile Method; Surfaces Having Stratified Functional Properties—Part 2: Height

¹ This test method is under the jurisdiction of ASTM Committee D02 on Petroleum Products and Lubricants and is the direct responsibility of Subcommittee D02.L0 on Industrial Lubricants.

Current edition approved Nov. 1, 2005. Published January 2006. DOI: 10.1520/D7217-05.

² For referenced ASTM standards, visit the ASTM website, www.astm.org, or contact ASTM Customer Service at service@astm.org. For *Annual Book of ASTM Standards* volume information, refer to the standard's Document Summary page on the ASTM website.

³ Available from Beuth Verlag GmbH, Burggrafenstrasse 6, D-10787 Berlin, Germany.

Characterization Using Linear Material Ratio Curve [Replacement of DIN 4776:1990: Measurement of Surface Roughness; Parameters R_K , R_{PK} , R_{VK} , M_{r1} , M_{r2} for the Description of the Material Portion]³

SAE AS5272 Lubricant, Solid Film, Heat Cured, Corrosion Inhibiting Procurement Specification⁴

AMS 2562B⁵

3. Terminology

3.1 Definitions:

3.1.1 *break-in, n—in tribology*, an initial transition process occurring in newly established wearing contacts, often accompanied by transients in coefficient of friction or wear rate, or both, which are uncharacteristic of the given tribological system's long-term behavior. **G40**

3.1.2 *coefficient of friction, μ or f , n—in tribology*, the dimensionless ratio of the friction force (F) between two bodies to the normal force (N) pressing these bodies together. **G40**

3.1.3 *Hertzian contact area, n*—the apparent area of contact between two nonconforming solid bodies pressed against each other, as calculated from Hertz's equations of elastic deformation. **G40**

3.1.4 *Hertzian contact pressure, n*—the magnitude of the pressure at any specified location in a Hertzian contact area, as calculated from Hertz's equations of elastic deformation. **G40**

3.1.5 *lubricant, n*—any material interposed between two surfaces that reduces the friction or wear, or both between them. **D4175**

3.1.6 *solid bonded film (sbf), n*—consists of physically dried or chemically hardened (cured) bonded solid films as well as of inorganic matrices containing embedded organic or inorganic, or both, solid lubricants with or without lattice layers or soft metals or combinations of these. Synonyms—*solid film lubricants* (Test Method **D2510**), *bonded solid film lubricant* (SAE AS5272), and *thin lubricating film* (**AMS 2562B**).

3.1.6.1 *Discussion*—Dry solid film lubricants are dry coatings consisting of lubricating powders in a solid matrix bonded

⁴ Available from Society of Automotive Engineers (SAE), 400 Commonwealth Dr., Warrendale, PA 15096-0001.

⁵ Aerospace Material Specifications.

to one or both surfaces to be lubricated.

D2510

3.1.7 *Ra (C.L.A.), n*—in measuring surface finish, the arithmetic average of the absolute distances of all profile points from the mean line for a given distance.⁶

3.1.8 *Rz (DIN), n*—in measuring surface finish, the average of all *Ry* values (peak to valley heights) in the assessment length.⁷

3.1.9 *Rpk, n*—reduced peak height according to **DIN EN ISO 13565-2:1998**. *Rpk* is the mean height of the peak sticking out above the core profile section.

3.1.10 *Rvk, n*—reduced valley height according to **DIN EN ISO 13565-2:1998**. *Rvk* is the mean depth of the valley reaching into the material below the core profile section.

3.2 Definitions of Terms Specific to This Standard:

3.2.1 *extreme pressure, adj*—in lubrication, characterized by metal surfaces in contact under high-stress rubbing conditions.

3.2.2 *seizure, n*—localized fusion of metal between the rubbing surfaces of the test pieces.

3.2.2.1 *Discussion*—Seizure is indicated by a sharp rise in the coefficient of friction, over steady state, of greater than 0.2 for over 20 s. In severe cases, a stoppage in the motor will occur.

3.2.3 *SRV, n*—Schwingung, Reibung, Verschleiss (German); oscillating, friction, wear (English translation).

4. Summary of Test Method

4.1 This test method is performed on an SRV test machine using a steel test ball oscillating against a steel test disk with lubricant between them. Test load is increased in 100-N increments until seizure occurs. The load, immediately prior to the load at which seizure occurs, is measured and reported.

NOTE 1—Test frequency, stroke length, temperature, and ball and disk material can be varied to simulate field conditions. The test ball yields point-contact geometry. To obtain line or area contact, test pieces of differing configurations can be substituted for the test balls.

5. Significance and Use

5.1 This laboratory test method can be used to quickly determine extreme pressure properties of parts coated with solid bonded films at selected temperatures specified for use in unlubricated applications where high-speed vibrational or start-stop motions are present with high Hertzian point contact. This test method has found wide application in qualifying solid bonded films used in automotive door lock mechanisms, hinge joints, bolts, and in aerospace. This test method is a material and application oriented approach for characterizing the tribological behaviour using random, discrete and constant parameter combinations. Users of this test method should determine whether results correlate with field performance or other applications.



FIG. 1 SRV Test Machine, Model III

6. Apparatus

6.1 *SRV Test Machine*,⁸ illustrated in **Figs. 1 and 2**.

7. Reagents and Materials

7.1 *Test Balls*,⁸ 52100 steel, 60 ± 2 Rc hardness, 0.025 ± 0.005 - μm Ra surface finish, $\text{Ø} = 10$ -mm diameter.

NOTE 2—The test can also be performed using rollers of antifriction bearings ($\text{Ø} = 15$ mm; length = 22 mm, parabolic border regions). Using 2000 N as normal force possible in SRV III models conducts only to a maximum Hertzian contact pressure of 808 MPa, which is far away from the capability of most SBFs.

7.2 *Lower Test Disk*⁸ vacuum arc remelted (VAR) AISI 52100 steel with a inclusion rating using method D, Type A, as severity level number of 0.5 according to Test Methods **E45**, Specification **A295/A295M** or a inclusion sum value $K1 \leq 10$ according to **DIN EN ISO 683-17** and spheroidized annealed to obtain globular carbide, 60 ± 2 Rc hardness, the surfaces of the disk being lapped and free of lapping raw materials. The topography of the disk will be determined by four values: $0.5 \mu\text{m} < Rz < 0.650 \mu\text{m}$; $0.035 \mu\text{m} < \text{C.L.A. (Ra)} < 0.050 \mu\text{m}$, $0.020 \mu\text{m} < Rpk < 0.035 \mu\text{m}$ and $0.050 \mu\text{m} < Rvk < 0.075 \mu\text{m}$, $\text{Ø} = 24$ -mm diameter by 7.85 mm thick.

NOTE 3—The DIN 17230-1980 was replaced by **DIN EN ISO 683-17**.

7.3 *n-Heptane*, reagent grade. (**Warning**—Flammable. Health hazard.)

7.4 *Isopropanol*, reagent grade. (**Warning**—Flammable. Health hazard.)

7.5 *Toluene*, reagent grade. (**Warning**—Flammable. Health hazard.)

7.6 *Cleaning Solvent*, a mixture of equal volumes of *n*-heptane, isopropanol, and toluene. (**Warning**—Flammable. Health hazard.)

⁶ Amstutz, Hu, "Surface Texture: The Parameters," *Bulletin MI-TP-003-0785*, Sheffield Measurement Division, Warner and Swasey, 1985, p. 21.

⁷ Amstutz, Hu, "Surface Texture: The Parameters," *Bulletin MI-TP-003-0785*, Sheffield Measurement Division, Warner and Swasey, 1985, pp. 31, 29.

⁸ The sole source of supply of the apparatus known to the committee at this time is Optimol Instruments GmbH, Westendstr. 125, D-80339 Munich, Germany. If you are aware of alternative suppliers, please provide this information with round robin data to ASTM Headquarters. Your comments will receive careful consideration at a meeting of the responsible technical committee, which you may attend.

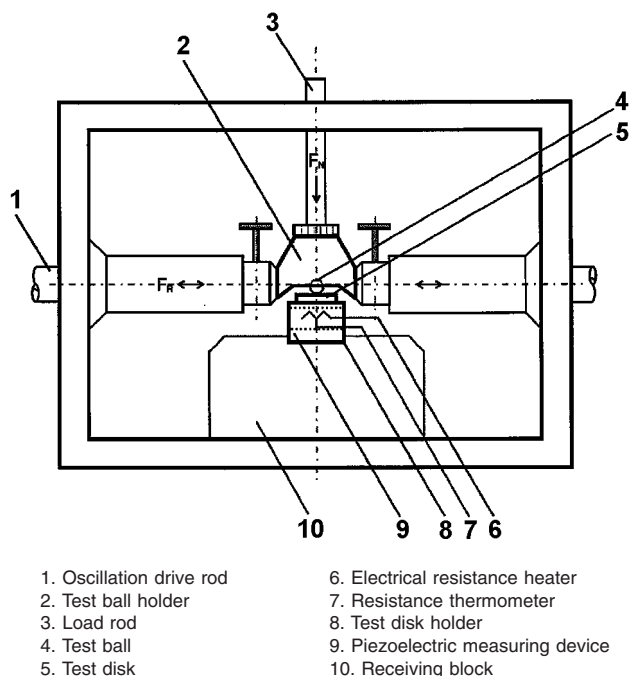

FIG. 2 Test Chamber Elements

- | | |
|--------------------------|-----------------------------------|
| 1. Oscillation drive rod | 6. Electrical resistance heater |
| 2. Test ball holder | 7. Resistance thermometer |
| 3. Load rod | 8. Test disk holder |
| 4. Test ball | 9. Piezoelectric measuring device |
| 5. Test disk | 10. Receiving block |

8. Preparation of Apparatus

8.1 Turn on the test machine and chart recorder or the PC and allow to warm up for 15 min prior to running tests.

8.2 Select the friction data to be presented in the crest peak value position in accordance with the manufacturer's directions.

NOTE 4—In most cases, this is accomplished by positioning the sliding switch on electronic card NO. 291.35.20E (front side of electronics behind the front panel) and the sliding switch located back on the panel of the control unit.

- 8.3 Turn the stroke knob to ZERO.
- 8.4 Switch the stroke adjustment to AUTO position.
- 8.5 Set the frequency to 20 Hz.

8.6 Set the desired span and calibrate the chart recorder in accordance with the manufacturer's instructions. Select the desired chart speed.

9. Procedure

9.1 Check the coated disk for visible damage or corrosion. Clean the test ball and coated disk by wiping the surfaces with laboratory tissue soaked with the cleaning solvent. Repeat wiping until no dark residue appears on the tissue. Immerse the test ball and disk in a beaker of the cleaning solvent under ultrasonic vibration for 10 min. Dry the test ball and disk with a clean tissue to ensure no streaking occurs on the surface.

NOTE 5—Ensure that the binder is resistant to the solvent. In the case that the binder is not resistant to the solvent, wipe only the coated disk surface with a laboratory tissue.

9.2 Place the cleaned test ball on the top and in the middle of the coated disk specimen.

9.3 Ensure the machine is unloaded (indicated by a load reading of -13 or -14 N) and carefully place coated disk specimen and test ball on the test area platform.

9.4 Tighten both the ball and disk clamps until resistance to tightening just begins. Then load unit to 20 N and tighten the ball and disk clamps to a torque of 2.5 N·m. Maintain the load of 20 N for break-in.

9.5 Turn on the heater control, and set to the desired temperature, for example, 50°C.

9.6 Set the load charge amplifier to setting that corresponds to the 400-N load.

9.7 Change the load charge amplifier at each load in accordance with the manufacturer's instructions when the coefficient of friction at each test load is to be studied.

9.8 When the temperature has stabilized, turn on the chart recorder or PC and depress the drive start toggle switch until the timer begins to count and then adjust the stroke amplitude knob to 2.00 mm.

9.9 When the digital timer reaches 30 s, increase the load to 20 N using the slow ramp speed rate and maintain this load for 2 min. The 2-min interval includes the loading ramp sequence. Increase the load by 10 N every 1, 3, or 6 min using the slow ramp until the load limit of the test apparatus is attained, or failure occurs. Failure is indicated by a rise in coefficient of friction of greater than 0.2 over steady state for over 20 s or a stoppage in the oscillating of the test machine.

NOTE 6—Because a 30-s break-in at xxx N is used, the load increase times will occur on the half minute of even minutes.

NOTE 7—The SRVII test machines available after 1992 have a maximum load of 1400 N and SRVIII/IV test machines after 1995 of 2000 N. Optimol Instruments supplies an upgrade kit to allow SRVI/II machines to operate with 1600 N, if needed.⁸

9.10 When the 1200-N load run or maximum load of the test apparatus is completed or failure occurs, turn off the heater control, release the load to minimum setting, (typically -13 or -14 N), and remove the test ball and disk test specimen.

NOTE 8—When using SRV III and IV models, clean and install the specimens as specified under 9.1-9.4. The test parameters are to be entered via the control software. The test will be run automatically. Test results will be displayed and saved.

10. Report

10.1 Report the following information:

10.1.1 Report all parameters used to evaluate material as follows:

- 10.1.1.1 Temperature, °C,
- 10.1.1.2 Stroke, mm,
- 10.1.1.3 Frequency, Hz,
- 10.1.1.4 Relative humidity in %,
- 10.1.1.5 Load step interval in seconds,
- 10.1.1.6 Test ball material,
- 10.1.1.7 Test disk material,
- 10.1.1.8 Solid bonded film test coating, and
- 10.1.1.9 Pretreatment of disk.

NOTE 9—Pretreatment can consist in sandblasting followed by phosphate treatment (manganese, zinc, or iron base).

NOTE 10—As especially under unlubricated conditions the tribological properties depends from the relative humidity of the surrounding air, this test quantity has to be reported or controlled.

10.2 Report the highest test load (pass load) at which no seizure occurred.

11. Precision and Bias ⁹

11.1 Ten cooperators tested two different, commercial available solid bonded films at one temperature using three different times for load increase of 1, 3, and 6 min and 10 mm balls and flat disks using AISI 52100 (100Cr6H) in repeated tests. A poly(amidimid) bonded, MoS₂ containing SBF was supplied by SBF1 and a “white” PTFE-containing SBF by SBF2. The cooperators reported relative humidities between 40 and 50 %. All disks were sand blasted (Frigosit 100 mesh) and phosphated. ADJD6300 (D2PP software) was used for the statistical analysis of the data.¹⁰

11.2 The following criteria should be used for judging the acceptability of results (95 % probability) for solid bonded films, which have load carrying capacities of up to 4000 MPa or less in the SRV apparatus using an oscillating frequency of 20 Hz, a temperature of 50°C and 2 mm of stroke (see [Appendix X1](#)).

11.2.1 *Repeatability*—The difference between successive results obtained by the same operator with the same apparatus under constant operating conditions on identical test material

⁹ Supporting data have been filed at ASTM International Headquarters and may be obtained by requesting Research Report RR:D02-1585.

¹⁰ Available from ASTM International Headquarters. Order Adjunct No. ADJD6300.

would, in the long run, in the normal and correct operation of the test method exceed the following values only in one case in twenty.

for tests run with 1 min: 0.25 *X*

for tests run with 3 min: 0.44 *X*

for tests run with 6 min: 0.45 *X*

where:

X = the average of two results, *N*.

11.2.2 *Reproducibility*—The difference between two single and independent results obtained by different operators working in different laboratories on identical test materials would, in the long run, exceed the following values only in one case in twenty.

for tests run with 1 min: 0.85 *X*

for tests run with 3 min: 0.48 *X*

for tests run with 6 min: 0.29 *X*

where:

X = the average of two results, *N*.

11.3 *Bias*—The evaluation of load-carrying capacity of lubricating grease by this test method has no bias because load-carrying capacity can be defined only in terms of the test method.

12. Keywords

12.1 extreme pressure; load-carrying capacity; oscillating; solid bonded film; solid film lubricant; SRV

APPENDIXES

(Nonmandatory Information)

X1. SUMMARY OF THE ROUND ROBIN TEST PERFORMED IN 2004

TABLE X1.1 Pass Loads of Solid Bonded Films (Ø = 10 mm Ball; 10 N load increment at 50°C; ν = 20 Hz)

NOTE 1—The repeatability and the reproducibility were calculated using ADJD6300 (D2PP software).

NOTE 2—Values in parentheses represent an initial, average Hertzian contact pressure using the mean value of the highest O.K.-load.

ASTM D 7217	SBF1	SBF1	SBF1	SBF2	SBF2	SBF2
Time for load increase	1 min	3 min	6 min	1 min	3 min	6 min
Statistical quantities	Highest test load [N]	Highest test load [N]	Highest test load [N]	Highest test load [N]	Highest test load [N]	Highest test load [N]
Number of Results	19	20	20	20	20	20
Degree of freedom	10	10	9	10	15	11
Mean (MPa)	251 (1.971)	202.0 (1.834)	201.0 (1.831)	101.0 (1.455)	64.0 (1.250)	48.0 (1.135)
Standard deviation	±67.6	±45.3	±63.2	±22.8	±12.4	±10.3
Reproducibility, <i>R</i>	213.2	142.86	202.2	71.8	37.6	31.2
Repeatability, <i>r</i>	59.4	34.5	19.9	17.3	28.2	14.1

X2. INTERPRETATION OF THE SEIZURE CRITERIA READING THE COEFFICIENT OF FRICTION IN THE SAMPLE RECORDING CHART

X2.1 The evolution of the friction force signal is dependent on the type of the grease under test. Different manifestations of the friction force curve need not necessarily be indicative of adhesion having occurred. In the following are given some typical examples which may guide the user to determine the moment of seizure. These figures were approved by the DIN 51834 working group and D02.G0 in 2003.

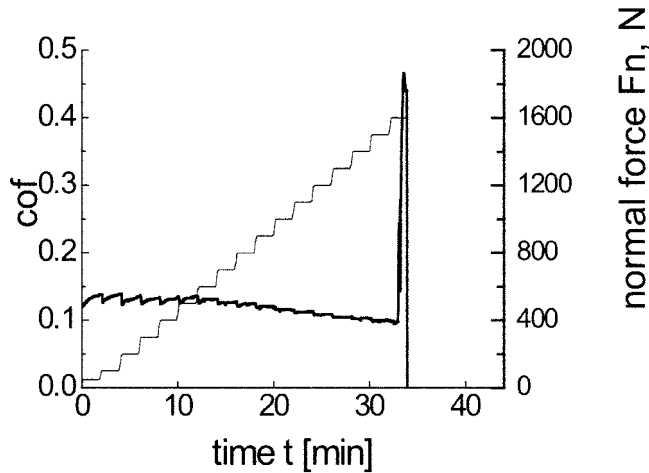

NOTE—The sharp and high rise on the friction force at 34 min leads to stopping of the machine and indicates seizure.

FIG. X2.1 Sample Recording Chart During Step Load Test

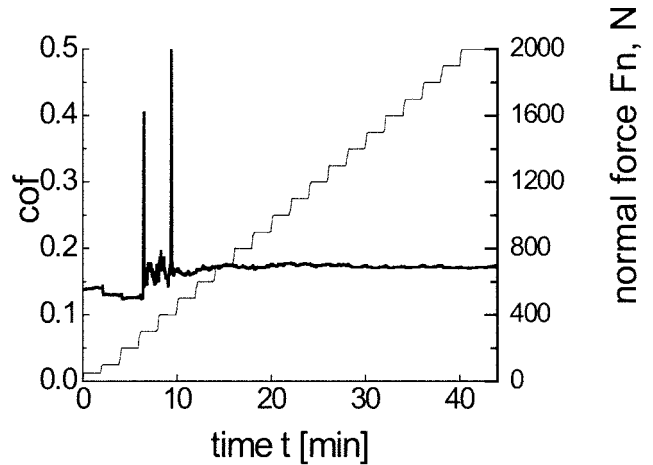

NOTE—The sharp, but short rise on the friction force at 6 min and a second at 9 min is considered as an event of seizure, since the level of the coefficient of friction increased, even though the grease reaches the highest load. This can be due to a short period of deficient lubrication or by a poor homogenized grease. In this case, it is recommended re-run and stop the test after different load steps for inspection of the wear scar and track for adhesive wear mechanisms.

FIG. X2.3 Sample Recording Chart During Step Load Test

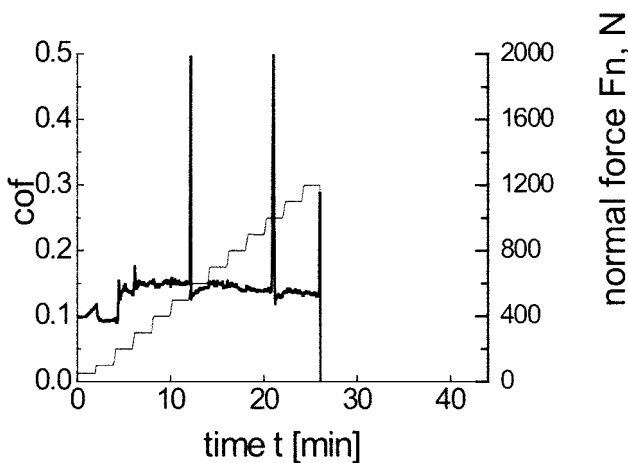

NOTE—The sharp and high rise on the friction force at 12 and 21 min are not considered as seizure indication, since the level of coefficient of friction remained unchanged. Seizure load is the stopping of the machine at 26 min.

FIG. X2.2 Sample Recording Chart During Step Load Test

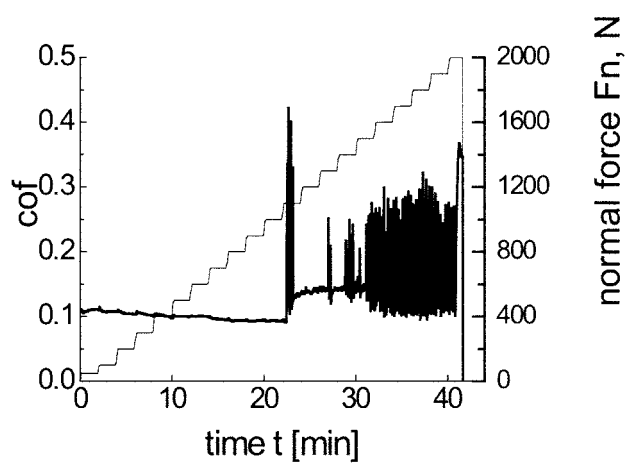

NOTE—The sharp, but short rise on the friction force at 22 min over 20 s is considered as seizure, since the level of the coefficient of friction increased even though the grease can support two more load steps. The seizure occurs at 24 min.

FIG. X2.4 Sample Recording Chart During Step Load Test

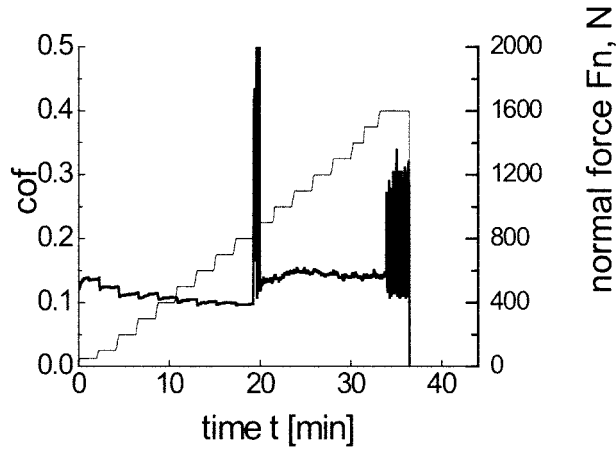

NOTE—The sharp, but short rise on the friction force at 20 min over 20 s is considered as seizure, since the level of the coefficient of friction increased, even though the grease can support six more load steps. The seizure occurs at 19 min with adhesive wear mechanisms in the wear track.

FIG. X2.5 Sample Recording Chart During Step Load Test

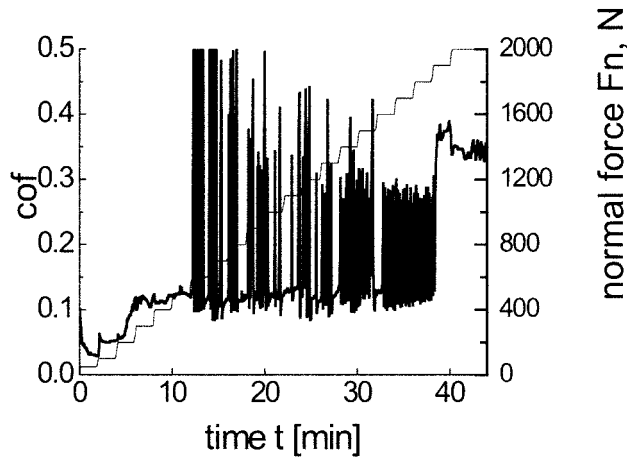

NOTE—The rise on the friction force after 5 min is difficult to validate the time of seizure, even though the grease can support the highest load, where the rise is limited to $<\Delta 0.2$. Seizure was noted at 14 min. In this case, it is recommended re-run and stop the test after different load steps for inspection of the wear scar and track for adhesive wear mechanisms.

FIG. X2.6 Sample Recording Chart During Step Load Test

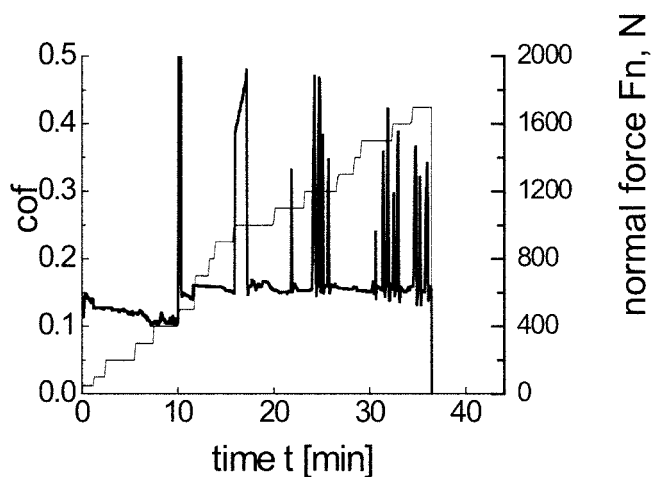

NOTE—The first sharp rise at 10 min the friction force is considered as seizure, since the level of the coefficient of friction increased, even the machine stops at 36 min. In this case, it is recommended re-run and stop the test after different load steps for inspection of the wear scar and track for adhesive wear mechanisms.

FIG. X2.7 Sample Recording Chart During Step Load Test

ASTM International takes no position respecting the validity of any patent rights asserted in connection with any item mentioned in this standard. Users of this standard are expressly advised that determination of the validity of any such patent rights, and the risk of infringement of such rights, are entirely their own responsibility.

This standard is subject to revision at any time by the responsible technical committee and must be reviewed every five years and if not revised, either reapproved or withdrawn. Your comments are invited either for revision of this standard or for additional standards and should be addressed to ASTM International Headquarters. Your comments will receive careful consideration at a meeting of the responsible technical committee, which you may attend. If you feel that your comments have not received a fair hearing you should make your views known to the ASTM Committee on Standards, at the address shown below.

This standard is copyrighted by ASTM International, 100 Barr Harbor Drive, PO Box C700, West Conshohocken, PA 19428-2959, United States. Individual reprints (single or multiple copies) of this standard may be obtained by contacting ASTM at the above address or at 610-832-9585 (phone), 610-832-9555 (fax), or service@astm.org (e-mail); or through the ASTM website (www.astm.org). Permission rights to photocopy the standard may also be secured from the ASTM website (www.astm.org/COPYRIGHT/).