



Standard Test Method for Evaluation of Automotive Engine Oils in the Sequence IIIG, Spark-Ignition Engine¹

This standard is issued under the fixed designation D7320; the number immediately following the designation indicates the year of original adoption or, in the case of revision, the year of last revision. A number in parentheses indicates the year of last reapproval. A superscript epsilon (ε) indicates an editorial change since the last revision or reapproval.

INTRODUCTION

The test method described in this standard can be used by any properly equipped laboratory; it does not require the assistance of anyone outside that laboratory. However, the ASTM Test Monitoring Center (TMC)² provides reference oils and an assessment of the test results obtained on those oils by the laboratory (see [Annex A1](#)). By these means, the laboratory will know whether their use of the test method gives results statistically similar to those obtained by other laboratories. Furthermore, various agencies require that a laboratory utilize the TMC services in seeking qualification of oils against specifications. For example, the U.S. Army imposes such a requirement in connection with several Army engine lubricating oil specifications.

Accordingly, this test method is written for use by laboratories that utilize the TMC services. Laboratories that choose not to use those services may simply ignore those portions of the test method that refer to the TMC.

This test method may be modified by means of Information Letters issued by the TMC. In addition, the TMC may issue supplementary memoranda related to the test method (see [A1.8](#)).

1. Scope

1.1 This test method covers an engine test procedure for evaluating automotive engine oils for certain high-temperature performance characteristics, including oil thickening, varnish deposition, oil consumption, as well as engine wear. Such oils include both single viscosity grade and multiviscosity grade oils that are used in both spark-ignition, gasoline-fueled engines, as well as in diesel engines.

1.1.1 Additionally, with nonmandatory supplemental requirements, a IIIGA Test (Mini Rotary Viscometer and Cold Cranking Simulator measurements), a IIIGVS Test (EOT viscosity increase measurement), or a IIIGB Test (phosphorous retention measurement) can be conducted. These supplemental test procedures are contained in [Appendix X1](#), [Appendix X2](#), and [Appendix X3](#), respectively.

¹ This test method is under the jurisdiction of ASTM Committee D02 on Petroleum Products and Lubricants and is the direct responsibility of Subcommittee D02.B0.01 on Passenger Car Engine Oils.

Current edition approved Oct. 1, 2009. Published November 2009. Originally approved in 2006. Last previous edition approved in 2009 as D7320-09. DOI: 10.1520/D7320-09a.

² Until the next revision of this test method, the ASTM Test Monitoring Center will update changes in the test method by means of information letters. Information letters may be obtained from the ASTM Test Monitoring Center, 6555 Penn Avenue, Pittsburgh, PA 15206-4489. Attention: Administrator. This edition incorporates revisions in all information letters through No. 09-1.

NOTE 1—Companion test methods used to evaluate engine oil performance for specification requirements are discussed in SAE J304.

1.2 The values stated in SI units are to be regarded as standard. No other units of measurement are included in this standard.

1.2.1 *Exception*—Where there is no direct SI equivalent such as screw threads, national pipe threads/diameters, and tubing size.

1.3 *This standard does not purport to address all of the safety concerns, if any, associated with its use. It is the responsibility of the user of this standard to establish appropriate safety and health practices and determine the applicability of regulatory limitations prior to use.* Specific warning statements are provided in [6.14.1.1](#) and [7.1](#).

1.4 This test method is arranged as follows:

	Section
Introduction	
Scope	1
Referenced Documents	2
Terminology	3
Summary of Test Method	4
Significance and Use	5
Apparatus	6
Laboratory	6.1
Drawings	6.2
Specified Equipment	6.3
Test Engine	6.4
Engine Parts	6.4.1
Engine Speed and Load Control	6.5

	Section		Section
Fluid Conditioning Module	6.6	Pressure Checking of Engine Coolant System	9.43
Engine Cooling System	6.6.1	Lifting of Assembled Engines	9.44
Flushing Tank	6.7	Mounting the Engine on the Test Stand	9.45
Coolant Mixing Tank	6.8	External Cooling System Cleaning	9.46
Condenser Cooling Systems	6.9	Engine Coolant Jacket Cleaning (Flushing)	9.47
Engine Oil-Cooling System	6.10	Coolant Charging	9.48
Fuel System	6.11	Test Oil Charging	9.49
Induction Air Supply Humidity, Temperature, and Pressure	6.12	Engine Oil Pump Priming	9.50
Temperature Measurement	6.13	Calibration	10
Thermocouple Location	6.13.1	Laboratory and Engine Test Stand Calibration	10.1
Air-to-Fuel Ratio Determination	6.14	Testing of Reference Oils	10.2
Injector Flow Testing	6.14.1	Reference Oil Test Frequency	10.3
Exhaust and Exhaust Back Pressure Systems	6.15	Reporting of Reference Oil Test Results	10.4
Blowby Flow Rate Measurement	6.16	Evaluation of Reference Oil Test Results	10.5
Pressure Measurement and Sensor Location	6.17	Status of Non-Reference Oil Tests Relative to Reference Oil Test	10.6
Reagents and Materials	7	Status of Test Stands Used for Non-Standard Tests	10.7
Test Fuel	7.1	Data Acquisition and Control	10.8
Engine and Condenser Coolant	7.2	Sample Rate	10.8.1
Coolant Additive	7.3	Measurement Accuracy	10.8.2
Coolant Preparation	7.4	Temperature	10.8.3
Pre-Test Cleaning Materials	7.5	Pressure	10.8.4
Sealing and Anti-seize Compounds	7.6	Flow	10.8.5
Test Oil Sample Requirements	8	Speed	10.8.6
Preparation of Apparatus	9	Load	10.8.7
Condenser Cleaning	9.1	Measurement Resolution	10.8.8
Intake Manifold Cleaning	9.2	System Time Response	10.8.9
Cleaning of Engine Parts (other than the block and heads)	9.3	Quality Index	10.8.10
Connecting Rod Cleaning	9.4	Engine Operating Procedure	11
Engine Block Cleaning	9.5	Dipstick and Hole Plug	11.1
Cylinder Head Cleaning	9.6	Dipstick Hole O-ring	11.2
Engine Build-up Procedure	9.7	Engine Start-up and Shutdown Procedures	11.3
General Information	9.7.1	Start-up	11.4
Special Parts	9.7.2	Scheduled Shutdown	11.5
Hardware Information	9.7.3	Non-Scheduled Shutdowns	11.6
Fastener Torque Specifications and Torquing Procedures	9.7.4	Oil Sampling	11.7
Main Bearing Cap Bolts	9.7.4.1	Oil Leveling	11.8
Cylinder Head Bolts	9.7.4.2	Air-to-Fuel-Ratio Measurement and Control	11.9
Torques for Miscellaneous Bolts, Studs, and Nuts	9.7.4.3	Air-to-Fuel Ratio Verification	11.10
Parts Replacement	9.8	Blowby Flow Rate Measurement	11.11
Engine Block Preparation	9.9	NOx Determinations	11.12
Piston Fitting and Numbering	9.10	Data Recording	11.13
Piston Ring Fitting	9.10.1	Initial run (10 min)	11.14
Pre-Test Camshaft and Lifter Measurements	9.11	Engine Oil Quality Testing (100 h)	11.15
Camshaft Bearing Installation	9.12	Test Termination	11.16
Camshaft Installation	9.13	Determination of Test Results	12
Main Bearings	9.14	Engine Disassembly	12.2
Crankshaft Installation	9.14.1	Preparation of Parts for Rating of Sticking, Deposits, and Plugging	12.3
Main Bearing Cap Installation	9.14.2	Piston Deposit Rating	12.4
Crankshaft Sprocket	9.15	Post-Test Camshaft and Lifter Wear Measurements	12.5
Camshaft Sprocket and Timing Chain	9.16	Viscosity Test	12.6
Crankshaft End Play	9.17	Testing Oil Samples for Wear Metals	12.7
Piston Pin Installation	9.18	Blowby Flow Rate Measurements	12.8
Piston Installation	9.18.1	Oil Consumption Computation	12.9
Harmonic Balancer	9.19	Photographs of Test Parts	12.10
Connecting Rod Bearings	9.20	Retention of Representative Test Parts	12.11
Engine Front Cover	9.21	Severity Adjustments	12.12
Coolant Inlet Adapter	9.22	Determination of Operational Validity	12.13
Oil Dipstick Hole	9.23	Report	13
Oil Pan	9.24	Report Forms	13.1
Cylinder Head Assembly	9.25	Precision of Reported Units	13.2
Adjustment of Valve Spring Loads	9.26	Precision and Bias	14
Cylinder Head Installation	9.27	Keywords	15
Hydraulic Valve Lifters	9.28	The Role of the ASTM Test Monitoring Center (TMC) and the Calibration Program	Annex A1
Pushrods	9.29	Sequence IIIG Test Parts Replacement Guidelines	Annex A2
Valve Train Loading	9.30	Sequence IIIG Determination Volume of Engine Oilin Pan	Annex A3
Intake Manifold	9.31	Sequence IIIG Test Fuel Analysis	Annex A4
Rocker Covers	9.32	Sequence IIIG Test Reporting	Annex A5
Water Inlet Adapter	9.33	Sequence IIIG Test Air-to-Fuel Ratio Control Flow Chart	Annex A6
Condenser	9.34	Sequence IIIG Test Set Points and Control States	Annex A7
Coolant Outlet Adapter	9.35	Sequence IIIG Quality Index Upper and Lower Values	Annex A8
Oil Filter Adapter	9.36	Sequence IIIG Engine Oil Level Worksheet	Annex A9
Oil Sample Valve	9.37	Blowby Flow Rate Determination	Annex A10
Ignition System	9.38	Safety Hazards	Annex A11
Throttle Body	9.39	Sequence IIIG Blueprint Listing	Annex A12
Accessory Drive Units	9.40		
Exhaust Manifolds, Water-Cooled	9.41		
Engine Flywheel	9.42		

Fluid Condition Module components
 Engine Build Worksheets
 Sequence IIIGA Test Procedure
 Sequence IIIGVIS Test Procedure
 Sequence IIIGB Test Procedure

Section
 Annex A13
 Annex A14
 Appendix X1
 Appendix X2
 Appendix X3

2. Referenced Documents

2.1 ASTM Standards:³

- D86 Test Method for Distillation of Petroleum Products at Atmospheric Pressure
- D130 Test Method for Corrosiveness to Copper from Petroleum Products by Copper Strip Test
- D235 Specification for Mineral Spirits (Petroleum Spirits) (Hydrocarbon Dry Cleaning Solvent)
- D240 Test Method for Heat of Combustion of Liquid Hydrocarbon Fuels by Bomb Calorimeter
- D323 Test Method for Vapor Pressure of Petroleum Products (Reid Method)
- D381 Test Method for Gum Content in Fuels by Jet Evaporation
- D445 Test Method for Kinematic Viscosity of Transparent and Opaque Liquids (and Calculation of Dynamic Viscosity)
- D525 Test Method for Oxidation Stability of Gasoline (Induction Period Method)
- D1319 Test Method for Hydrocarbon Types in Liquid Petroleum Products by Fluorescent Indicator Adsorption
- D2699 Test Method for Research Octane Number of Spark-Ignition Engine Fuel
- D2700 Test Method for Motor Octane Number of Spark-Ignition Engine Fuel
- D3231 Test Method for Phosphorus in Gasoline
- D3237 Test Method for Lead in Gasoline by Atomic Absorption Spectroscopy
- D3244 Practice for Utilization of Test Data to Determine Conformance with Specifications
- D3338 Test Method for Estimation of Net Heat of Combustion of Aviation Fuels
- D3343 Test Method for Estimation of Hydrogen Content of Aviation Fuels
- D4052 Test Method for Density, Relative Density, and API Gravity of Liquids by Digital Density Meter
- D4175 Terminology Relating to Petroleum, Petroleum Products, and Lubricants
- D4485 Specification for Performance of Engine Oils
- D4684 Test Method for Determination of Yield Stress and Apparent Viscosity of Engine Oils at Low Temperature
- D4815 Test Method for Determination of MTBE, ETBE, TAME, DIPE, tertiary-Amyl Alcohol and C₁ to C₄ Alcohols in Gasoline by Gas Chromatography
- D5185 Test Method for Determination of Additive Elements, Wear Metals, and Contaminants in Used Lubricating Oils and Determination of Selected Elements in Base

Oils by Inductively Coupled Plasma Atomic Emission Spectrometry (ICP-AES)

- D5191 Test Method for Vapor Pressure of Petroleum Products (Mini Method)
- D5293 Test Method for Apparent Viscosity of Engine Oils and Base Stocks Between –5 and –35°C Using Cold-Cranking Simulator
- D5452 Test Method for Particulate Contamination in Aviation Fuels by Laboratory Filtration
- D5453 Test Method for Determination of Total Sulfur in Light Hydrocarbons, Spark Ignition Engine Fuel, Diesel Engine Fuel, and Engine Oil by Ultraviolet Fluorescence
- D5862 Test Method for Evaluation of Engine Oils in Two-Stroke Cycle Turbo-Supercharged 6V92TA Diesel Engine⁴
- D6984 Test Method for Evaluation of Automotive Engine Oils in the Sequence IIIF, Spark-Ignition Engine
- E29 Practice for Using Significant Digits in Test Data to Determine Conformance with Specifications
- E191 Specification for Apparatus For Microdetermination of Carbon and Hydrogen in Organic and Organo-Metallic Compounds
- E608/E608M Specification for Mineral-Insulated, Metal-Sheathed Base Metal Thermocouples
- E1119 Specification for Industrial Grade Ethylene Glycol
- IEEE/ASTM SI 10 Standard for Use of the International System of Units (SI): The Modern Metric System³
- 2.2 Military Specification:⁵
 - MIL-PRF-2104, Lubricating Oil, Internal Combustion Engine, Tactical Service
- 2.3 SAE Standards:⁶
 - J183, Engine Oil Performance and Engine Service Classification (Other Than “Energy-Conserving”)
 - J300, Engine Oil Viscosity Classification *HS-23/00
 - J304, Engine Oil Tests
- 2.4 Other ASTM Documents:
 - Guidelines for Calibration⁷
 - The Lubricant Test Monitoring System, Sequence IIIG Test Control Chart Technique for Developing and Applying Severity Adjustments (SA)⁸

3. Terminology

3.1 Definitions:

3.1.1 *blowby, n*—in internal combustion engines, the combustion products and unburned air-and-fuel mixture that enter the crankcase. **D4175**

⁴ Withdrawn. The last approved version of this historical standard is referenced on www.astm.org.

⁵ Hardcopy available from Document Automation and Production Service, Building 4/D, 700 Robbins Avenue, Philadelphia, PA 19111-5094. Also, can be downloaded from internet address: <http://assist2.daps.dla.mil/quicksearch/>.

⁶ Available from Society of Automotive Engineers, 400 Commonwealth Dr., Warrendale, PA 15096-0001. These standards are not available separately. Order either SAE Handbook, Vol. 3, or SAE Fuels and Lubricants Standards Manual, HS-23.

⁷ Guidelines for Calibration can be found in the Lubricant Test Monitoring System, available from the Test Monitoring Center, <http://www.astmtmc.cmu.edu/>

⁸ Sequence IIIG Test Control Chart Technique For Developing And Applying Severity Adjustments (SA), available at internet address: <ftp://ftp.astmtmc.cmu.edu/docs/ltns/ltns.pdf>

³ For referenced ASTM standards, visit the ASTM website, www.astm.org, or contact ASTM Customer Service at service@astm.org. For *Annual Book of ASTM Standards* volume information, refer to the standard’s Document Summary page on the ASTM website.

3.1.2 *BTDC (before top dead center)*, *adj*—the angular position of the crankshaft relative to its o position at the point of uppermost travel of the piston in the cylinder, used with the degree symbol (°). **D4175**

3.1.3 *calibrate*, *v*—to determine the indication or output of a measuring device with respect to that of a standard. **D4175**

3.1.4 *clogging*, *n*—the restriction of a flow path due to the accumulation of material along the flow path boundaries. **D4175**

3.1.5 *cold-stuck piston ring*, *n*—*in internal combustion engines*, a piston ring that is stuck when the piston and ring are at room temperature, but inspection shows that it was free during engine operation.

3.1.5.1 *Discussion*—A cold-stuck piston ring cannot be moved with moderate finger pressure. It is characterized by a polished face over its entire circumference, indicating essentially no blowby passed over the outside of the ring during operation. **D6593**

3.1.6 *correction factor*, *n*—a mathematical adjustment to a test result to compensate for industry wide shifts in severity.

3.1.7 *corrosion*, *n*—the chemical or electrochemical reaction between a material, usually a metal surface, and its environment that can produce a deterioration of the material and its properties. **D4175**

3.1.8 *debris*, *n*—*in internal combustion engines*, solid contaminant materials unintentionally introduced into the engine or resulting from wear. **D5862**

3.1.9 *engine oil*, *n*—a liquid that reduces friction or wear, or both, between the moving parts within an engine, and serves as a coolant. **D4485**

3.1.10 *EWMA*, *n*—abbreviation for exponentially-weighted moving average.

3.1.11 *free piston ring*, *n*—*in internal combustion engines*, a piston ring that will fall in its groove under the force of its own weight when the piston with the ring in a horizontal plane, is turned 90° (putting the ring in a vertical plane). **D4175**

3.1.11.1 *Discussion*—In determination of this condition, the ring may be touched slightly to overcome static friction.

3.1.12 *hot-stuck piston ring*, *n*—*in internal combustion engines*, a piston ring that is stuck when the piston and ring are at room temperature, and inspection shows that it was stuck during engine operation.

3.1.12.1 *Discussion*—The portion of the ring that is stuck cannot be moved with moderate finger pressure. A hot-stuck ring is characterized by varnish or carbon across a portion of its face, indicating that portion of the ring was not contacting the cylinder wall during engine operation. **D4175**

3.1.13 *Lubricant Test Monitoring System (LTMS)*, *n*—an analytical system in which ASTM calibration test data are used to manage lubricant test precision and severity (bias).

3.1.14 *LTMS date*, *n*—the date the test was completed unless a different date is assigned by the TMC.

3.1.15 *LTMS time*, *n*—the time the test was completed unless a different time is assigned by the TMC.

3.1.16 *lubricant*, *n*—any material interposed between two surfaces that reduces the friction or wear, or both, between them. **D4175**

3.1.17 *lubricating oil*, *n*—a liquid lubricant, usually comprising several ingredients, including a major portion of base oil and minor portions of various additives. **D4175**

3.1.18 *Material Safety Data Sheet, (MSDS)*, *n*—a fact sheet summarizing information about material identification; hazardous ingredients; health, physical, and fire hazards; first aid; chemical reactivities and incompatibilities; spill, leak, and disposal procedures; and protective measures required for safe handling and storage. **http://www.msdssearch.com**

3.1.19 *non-compounded engine oil*, *n*—a lubricating oil having a viscosity within the range of viscosities of oils normally used in engines, and that may contain anti-foam agents or pour depressants, or both, but not other additives. **D4175**

3.1.20 *non-reference oil*, *n*—any oil, other than a reference oil; such as a research formulation, commercial oil, or candidate oil. **D4175**

3.1.21 *oxidation*, *n*—*of engine oil*, the reaction of the oil with an electron acceptor, generally oxygen, that can produce deleterious acidic components often manifested as sludge formation, varnish formation, viscosity increase, or corrosion, or combination thereof. **D4175**

3.1.22 *quality index (QI)*, *n*—a mathematical formula that uses data from controlled parameters to calculate a value indicative of control performance.

3.1.23 *reference oil*, *n*—an oil of known performance characteristics, used as a basis for comparison.

3.1.23.1 *Discussion*—Reference oils are used to calibrate testing facilities, to compare the performance of other oils, or to evaluate other materials (such as seals) that interact with oils. **D4175**

3.1.24 *rust (coatings)*, *n*—*of ferrous alloys*, a corrosion product consisting of hydrated iron oxides. **D4175**

3.1.25 *SA*, *n*—abbreviation for severity adjustment.

3.1.26 *scoring*, *n*—*in tribology*, a severe form of wear characterized by the formation of extensive grooves and scratches in the direction of sliding. **D4175**

3.1.27 *scuffing*, *n*—*in lubrication*, surface damage resulting from localized welding at the interface of rubbing surfaces with subsequent fracture in the proximity of the weld area. **D4175**

3.1.28 *test oil*, *n*—any oil subjected to evaluation in an established procedure.

3.1.28.1 *Discussion*—It can be any oil selected by the laboratory conducting the test. It could be an experimental product or a commercially available oil. Often, it is an oil that is a candidate for approval against engine oil specifications (such as manufacturers' or military specifications, etc.).

3.1.29 *test procedure*, *n*—one where test parameters, apparatus, apparatus preparation, and measurements are principal items specified.

3.1.30 *used oil*, *n*—any oil that has been in a piece of equipment (for example, an engine, gearbox, transformer, or turbine), whether operated or not. **D4175**

3.1.31 *varnish*, *n*—*in internal combustion engines*, a hard, dry, generally lustrous, deposit that can be removed by solvents but not by wiping with a cloth. **D4175**

3.1.32 *wear*, *n*—the loss of material from, or relocation of material on, a surface.

3.1.32.1 *Discussion*—Wear generally occurs between two surfaces moving relative to each other, and is the result of mechanical or chemical action, or of a combination of mechanical and chemical actions. **D4175**

3.2 Definitions of Terms Specific to This Standard:

3.2.1 *build-up oil*, *n*—EF-411, non-compounded, ISO VG 32 (SAE 10) oil used in lubricating some of the Sequence IIIG parts during engine assembly.

3.2.2 *calibrated test stand*, *n*—a test stand on which Sequence IIIG engine oil tests are conducted within the LTMS as administered by the TMC. (See 10.1.)

3.2.3 *central parts distributor (CPD)*, *n*—the manufacturer and supplier of many of the parts and fixtures used in this test method.

3.2.3.1 *Discussion*—Because of the need for rigorous inspection and control of many of the parts used in this test method, and because of the need for careful manufacture of special parts and fixtures used, companies having the capabilities to provide the needed services have been selected as the official suppliers for the Sequence IIIG test method. These companies work closely with the original parts suppliers, with the Test Procedure Developer, and with the ASTM groups associated with the test method to help ensure that the equipment and materials used in the method function satisfactorily.

3.2.4 *special test parts (STP)*, *n*—parts that do not meet all the definitions of critical parts, non-production parts, or SPO parts, but shall be obtained only from the specified distributor.

3.2.5 *critical parts (CP)*, *n*—those components used in the test, which are known to affect test severity.

3.2.5.1 *Discussion*—Critical parts shall be obtained from the Central Parts Distributor or Special Parts Supplier, who will identify them with either a serial number or a batch/lot control number.

3.2.6 *EOT time (end of test time)*, *n*—20 min after the engine reaches 100 test h of operation, which allows 120 s for ramp-down/idle, a 15-min wait for oil to drain into the sump, and allows the operator 3.0 min to measure oil level.

3.2.7 *non-production parts (NP)*, *n*—components used in the test, which are available only through the Central Parts Distributor, Special Parts Supplier, or the Test Procedure Developer.

3.2.8 *participating laboratory*, *n*—a laboratory equipped to conduct Sequence IIIG tests, which conducts reference oil tests in cooperation with the TMC, in order to have calibrated test stands available for non-reference oil testing.

3.2.9 *pinched piston ring*, *n*—an installed piston ring which will not move in its groove under moderate finger pressure, but which has a polished face over its entire circumference indicating that it was free during engine operation; The ring may be restricted over varying degrees of its circumference.

3.2.10 *reference oil test*, *n*—a standard Sequence IIIG engine oil test of a reference oil designated by the TMC.

3.2.11 *service parts operations parts (SPO)*, *n*—these test components are obtained from Service Parts Operations a division of General Motors Corporation.

3.2.12 *sluggish piston ring*, *n*—an installed piston ring which it offers resistance to movement in its groove, but it can

be pressed into or out of the groove under moderate finger pressure; when so moved, it does not spring back (one that is neither free nor stuck).

3.2.13 *special parts supplier (SPS)*, *n*—the manufacturer and supplier of many of the parts and fixtures used in this test method.

3.2.14 *special test parts*, *n*—parts that do not meet all the definitions of critical parts, non-production parts, or SPO parts, but shall be obtained from the Special Parts Supplier.

3.2.15 *standard test (valid test)*, *n*—an operationally valid, full-length Sequence IIIG test conducted on a calibrated test stand in accordance with the conditions listed in this standard.

3.2.16 *stuck piston ring*, *n*—one that is either partially or completely bound in its groove and cannot be readily moved with moderate finger pressure.

3.2.17 *test procedure developer*, *n*—the group or agency which developed the Sequence IIIG test procedure before its standardization by ASTM, and which continues to be involved with the test in respect to modifications in the test method, development of Information Letters, supply of test parts, and so forth.

3.2.17.1 *Discussion*—In the case of the Sequence IIIG test, the Test Procedure Developer is General Motors Research and Development Center.

3.2.18 *test full mark*, *n*—the oil level established after the 10-min initial run-in.

3.2.19 *test stand*, *n*—a suitable foundation (such as a bedplate) to which is mounted a dynamometer, and which is equipped with a suitable data acquisition system, fluids process control system, supplies of electricity, compressed air, and so forth, to provide a means for mounting and operating an engine in order to conduct a Sequence IIIG engine oil test.

3.2.20 *test start*, *n*—introduction of test oil into the engine after the final assembly and mounting in the test stand.

3.2.21 *test start time*, *n*—the time that test oil was introduced into the engine on the test stand.

4. Summary of Test Method

4.1 A 3800 series II V-6 test engine block with a displacement of 3.8 L is solvent-cleaned, measured, and rebuilt; using new parts installed as specified in this test method.

4.2 The engine is installed on a test stand equipped with an appropriate data acquisition system, the required fluids process control system, and all necessary accessories for controlling speed, load, and various other operating parameters.

4.3 The engine is charged with the test oil.

4.4 The engine is operated for an initial run-in period of 10 min to check all test stand operating systems and to establish a zero hour oil level reading and initial oil viscosity sample.

4.5 Following the run-in and oil leveling period of 10 min, the engine is ramped up to test conditions over a 15 min period then operated under non-cyclic, moderately high speed, load, and temperature conditions for 100 h, in 20 h segments.

4.6 The initial oil level in the oil pan is determined after the 10 min initial run-in, and subsequent oil level calculations are determined during the oil leveling period at the end of each 20 h segment.

4.7 Used oil samples are taken after the 10 min initial run-in and after each 20 h test segment; kinematic viscosity at 40 °C is determined for each of the seven samples; the percentage change in viscosity of the five latter samples is determined relative to the viscosity of the first used oil sample (10 min initial run-in).

4.8 At the conclusion of the test, the engine is disassembled and the parts are visually rated to determine the extent of deposits formed. In addition, wear measurements are obtained.

5. Significance and Use

5.1 This test method was developed to evaluate automotive engine oils for protection against oil thickening and engine wear during moderately high-speed, high-temperature service.

5.2 The increase in oil viscosity obtained in this test indicates the tendency of an oil to thicken because of oxidation. In automotive service, such thickening can cause oil pump starvation and resultant catastrophic engine failures.

5.3 The deposit ratings for an oil indicate the tendency for the formation of deposits throughout the engine, including those that can cause sticking of the piston rings in their grooves. This can be involved in the loss of compression pressures in the engine.

5.4 The camshaft and lifter wear values obtained in this test provide a measure of the anti-wear quality of an oil under conditions of high unit pressure mechanical contact.

5.5 The test method was developed to correlate with oils of known good and poor protection against oil thickening and engine wear. Specially formulated oils that produce less than desirable results with unleaded fuels were also used during the development of this test.

5.6 The Sequence IIIG engine oil test has replaced the Sequence IIIF test and can be used in specifications and classifications of engine lubricating oils, such as the following:

5.6.1 Specification **D4485**,

5.6.2 Military Specification MIL-PRF-2104, and

5.6.3 SAE Classification J183.

6. Apparatus

6.1 *Laboratory*—Observe the following laboratory conditions to ensure good control of test operations, and good repeatability:

6.1.1 Maintain the ambient laboratory atmosphere relatively free of dirt, dust, and other contaminants.

6.1.2 Control the temperature of the room in which parts measurements are made so that the temperature for after-test measurements is within a range of ± 3 °C relative to the temperature for the before-test measurements. If difficulties with parts fits are encountered, consider the effects of temperature coefficient of expansion. See **6.2**.

6.1.3 Filter the air in the engine build-up area, and control its temperature and humidity to prevent accumulation of dirt or rust on engine parts.

6.1.4 If an engine is assembled in an area of controlled environment and moved to a non-controlled area, provide suitable protection of the engine so that moist air cannot enter the engine and promote rusting before the test.

6.1.5 Do not permit air from fans or ventilation systems to blow directly on an engine mounted on a test stand during test operation.

6.2 *Drawings*—Obtain the equipment drawings referenced in **Annex A12** of this test method from the TMC. Because the drawings may not be to scale or may not contain dimensions, when using them to fabricate special parts, do not use a dimensionless drawing as a pattern. Drawings supplied with dimensions are considered to be correct when the temperature of the equipment is (22 ± 3) °C, unless otherwise specified.

6.3 *Specified Equipment*—Use the equipment specified in the procedure whenever possible. Substitution of equivalent equipment is allowed, but only after equivalency has been proven to the satisfaction of the TMC, the Test Procedure Developer, and the ASTM Sequence IIIG Surveillance Panel.

6.3.1 Do not use heat lamps or fans directed at the engine, and do not use insulation on the engine, for oil or coolant temperature control.

6.3.1.1 *Discussion*—For operator safety and the protection of test components, the use of shielding and insulation on the exhaust system may be incorporated downstream of the oxygen sensor elbow.

6.4 *Test Engine*—The test engine is based on a 1996-97 L36 3800 series II V-6 engine with a displacement of 3.8 L, a compression ratio of 9.0:1, equipped with a production fuel injection system, a retrofit flat-tappet valvetrain, and a special Powertrain Control Module (PCM) for test specific dynamometer operation. Rebuild the engine as specified in this test method.

NOTE 2—Complete test engines are not available for purchase. Test engines can be rebuilt using parts and test kits. See *Sequence IIIG Engine Assembly Manual*.⁹ See **Annex A2** and **Annex A12** for listings of parts and related equipment.

6.4.1 *Engine Parts*—Use the engine parts specified in the Sequence IIIG Engine Assembly Manual.

6.4.1.1 Use all engine parts as received from the supplier, Central Parts Distributor, Special Parts Supplier, or original equipment manufacturer, unless modifications are specified in this test method or the Sequence IIIG Engine Assembly Manual.⁹

6.4.1.2 Any parts obtained for use in Sequence IIIG testing shall not be diverted to other applications.

6.4.1.3 Before disposing of any Sequence IIIG engine parts, destroy or otherwise render them useless for automotive engine applications.

6.5 *Engine Speed and Load Control*—Use dynamometer speed and load control systems that are capable of controlling the speed and load as specified in Section **11** of this procedure under Data Acquisition and Control.

6.6 *Fluid Conditioning Module*^{10,11}—To control the following parameters: engine coolant, condenser coolant, oil cooler

⁹ Sequence IIIG Engine Assembly Manual is available at internet address: ftp://ftp.astmtmc.cmu.edu/docs/gas/sequenceiii/procedure_and_ils/IIIF-EAM.pdf

¹⁰ The sole source of supply of the apparatus known to the committee at this time is Kunding Controls, 1771 Harmon Road, Auburn Hills, MI 48326.

¹¹ If you are aware of alternative suppliers, please provide this information to ASTM International Headquarters. Your comments will receive careful consideration at a meeting of the responsible technical committee,¹ which you may attend.

coolant, exhaust manifold coolant, and the test fuel supply. The system incorporates the following features: pumps, flow meters, flow control and three-way control valves, external heating and cooling systems, pressure regulator and low-point drains. The system integrates with the test stand data acquisition and control computer for process control. If a test laboratory wishes to build its own fluid conditioning module, a list of suitable equipment can be found in [Annex A13](#).

6.6.1 *Engine Cooling System*—The Fluid Conditioning Module system supplies non-pressurized coolant at a flow rate of 160 L/min and controls temperature at 115 °C at the engine coolant outlet. The system incorporates the following features: pump, vortex-type flow meter, flow control and three-way control valves, external heating and cooling systems, and low-point drains. The system integrates with the test stand data acquisition and control computer for process control and maintains the specified engine coolant temperature and flow. The system should be flushed with clean water at least once each reference period.

6.7 *Flushing Tank*—Use a flushing tank such as that shown in drawings RX-116924-C, RX-117230-E, and RX-117231-C to circulate the cleaning agents. Use plumbing materials that are impervious to the acidic cleaning agents (stainless steel is satisfactory).

6.8 *Coolant Mixing Tank*—Use a mixing tank such as that shown in drawing RX-117350-D to premix the engine coolant.

6.9 *Condenser Cooling System*—This system, contained in the Fluid Conditioning Module, supplies non-pressurized coolant at a flow rate of (10 ± 2) L/min and temperature controlled at 40 °C (see [Annex A8](#)) at the condenser outlet. The system incorporates the following features: condenser heat exchanger, BX-212-1 or OHT3F-075-1:^{11,12} condenser adapter fitting, pump, magnetic-type flow meter, flow control and three-way control valves, external heating and cooling systems, and low-point drains. The system integrates with the test stand data acquisition and control computer for process control and maintains the specified coolant temperature and flow.

6.10 *Engine Oil-Cooling System*—The system consists of an oil filter adapter, fitting adapter, oil cooler, and gaskets specified in the Sequence IIIG Engine Assembly Manual, Section 8 Sheet 3. The system uses engine coolant provided through the Fluid Conditioning Module and through a three-way valve as necessary to control the engine oil temperature at a flow rate of approximately 12.0 L/min. When testing high-oxidation sensitive oils, the oil cooling system may go into a by-pass mode, causing the oil cooler to be by-passed. In this condition, the TMC may allow engineering judgment for the oil temperature Quality Index on reference oil tests.

6.10.1 Replace the oil cooler after every test.

6.10.2 Do not use cuprous lines or fittings in the oil system.

6.10.3 Do not use magnetic plugs in the oil system.

6.10.4 Use suitable hose and fittings when plumbing the oil-cooling system.

6.10.5 The oil cooler or oil filter, or both can be replaced once each test if the oil filter pressure differential during test operations is greater than 100 kPa or if bypass operation is detected.

6.10.5.1 The oil cooler or oil filter, or both can be replaced only once each test (that is, if a filter is replaced at 30 h, the cooler cannot be replaced at 50 h).

6.10.5.2 If the oil filter is replaced during the test, drain any oil contained in the old oil filter into the new oil filter before installing it on the test engine.

6.10.5.3 Do not add new test oil to the engine as a result of oil filter or oil cooler replacement. Consider as oil consumption any oil lost as a result of oil filter or oil cooler replacement.

6.10.5.4 If the oil cooler or oil filter, or both are replaced during a test, place a note in the test report detailing what components were replaced and when they were replaced.

6.11 *Fuel System*—The Fluid Conditioning Module system contains a pressurized, recirculation fuel system, including a pressure regulator to provide (377.5 ± 12.5) kPa fuel pressure. The system should be switched off so no fuel pressure is present at the injector rail during engine shutdowns.

6.12 *Induction Air Supply Humidity, Temperature, and Pressure*—Maintain the throttle body intake air at a moisture content of (11.4 ± 0.7) g/kg of dry air, a dry bulb temperature of (35 ± 2) °C, and a static pressure of 0.050 kPa (see [Annex A7](#)). Measure temperature and pressure at the inlet air adapter.

6.13 *Temperature Measurement*—Use 3.2 mm metal-sheathed Specification [E608/E608M](#), iron-constantan (Type J) thermocouples for temperature measurements. Use the shortest possible thermocouples to meet the insertion depth requirements listed in this test method and minimize exposed thermocouple sheathing.

6.13.1 *Thermocouple Location*—Locate the sensing tip of all thermocouples in the center of the stream of the medium involved, unless otherwise specified.

6.13.1.1 *Oil Filter Adapter*—Install the thermocouple in the tapped hole in the oil filter adapter as shown in the Sequence IIIG Engine Assembly Manual, Section 8 Sheet 3.

6.13.1.2 *Oil Pan (Sump)*—Install the thermocouple in the oil sump drain plug OHT3F-063-1 with the tip extending (19 to 25) mm beyond the end of the sump drain plug.

6.13.1.3 *Engine Coolant In*—Install the thermocouple in the coolant inlet adapter OHT3F-031-1 with the sensing tip centered in the coolant flow.

6.13.1.4 *Engine Coolant Out*—Install the thermocouple for the coolant outlet OHT3F-034-1 with the sensing tip centered in the coolant flow.

6.13.1.5 *Condenser Coolant Out*—Locate the thermocouple in the coolant out fitting in the condenser with the sensing tip centered in the coolant flow.

6.13.1.6 *Blowby Gas*—Install the thermocouple at the outlet of the condenser with the sensing tip centered in the blowby gas flow.

6.13.1.7 *Fuel*—Install the thermocouple in the fuel rail fittings on the inlet side of the fuel rail.

6.13.1.8 *Inlet Air*—Install the thermocouple in the inlet air adapter, as shown in the Sequence IIIG Engine Assembly Manual, Section 8 Sheet 4.

¹² The sole source of supply of the apparatus known to the committee at this time is OH Technologies Inc. P.O. Box 5039, Mentor, OH 44061-5039.

6.14 *Air-to-Fuel Ratio Determination*—Determine the engine air-to-fuel ratio (AFR) by measuring the CO, CO₂, and O₂ components of the exhaust gas sample with electronic exhaust gas analysis equipment. When using electronic exhaust gas analyzers, take particular care to dry the exhaust gas sample prior to introducing it into the analyzer. Take the exhaust gas samples from the exhaust manifold exit flanges. See [Annex A6](#). (See Sequence IIIG Engine Assembly Manual, Section 8 Sheet 1.)

6.14.1 *Injector Flow Testing*—Flow test the fuel injectors before each test according to the following procedure:

6.14.1.1 Use aliphatic naphtha (**Warning**—Flammable. Health hazard.) as the calibration fluid.

6.14.1.2 Apply 276 kPa to the fuel rail.

6.14.1.3 Apply 13 V to the injector solenoid continuously.

6.14.1.4 Allow the injector to spray into a graduated cylinder capable of holding at least 250 mL.

6.14.1.5 Volume-check all injectors for 60 s and note the volume produced by each injector.

6.14.1.6 Observe the spray pattern that each injector produces; if the injector has a straight stream or dribbles, it should be discarded.

6.14.1.7 The six injectors that are to be installed on an engine fuel rail shall produce volumes that are within 5 mL of each other.

6.14.2 Remove the solvent that is remaining in the injector from the flow check using compressed air.

6.15 *Exhaust and Exhaust Back Pressure Systems*:

6.15.1 *Exhaust Manifolds and Pipes*—Install water-cooled exhaust manifolds and stainless runners as shown in the Sequence IIIG Engine Assembly Manual, Section 8 Sheet 2.

6.15.2 *Water-Jacketed Exhaust Pipes*—For safety, water-jacketed exhaust pipes or external water spray systems are allowed only when introduced beyond the Y pipe and after the system drops below the bedplate or enters the overhead loft.

6.15.3 *Exhaust Sample Lines*—Install exhaust sample lines in the two exhaust manifold exit flanges. Both left and right banks should use the same sample line location (inboard or outboard), as shown in the Sequence IIIG Engine Assembly Manual, Section 8 Sheet 1. Use good laboratory practice to ensure that water does not accumulate in the lines during engine operation.

6.15.4 *Back-Pressure Lines*—Install exhaust-backpressure lines in the two exhaust manifold exit flanges. Both left and right banks should use the same backpressure measurement location (inboard or outboard), as shown in the Sequence IIIG Engine Assembly Manual, Section 8 Sheet 1. Use good laboratory practice to ensure that water does not accumulate in the lines during engine operation.

6.16 *Blowby Flow Rate Measurement*—Use the sharp-edge orifice meter, part number RX-116169-A1, revision N, to measure engine blowby flow rates. (See [11.11](#).)

6.17 *Pressure Measurement and Pressure Sensor Location*—Use electronic pressure transducers located as indicated in this test method.

6.17.1 *Intake Manifold Vacuum*—Use a transducer having a range of (0 to 100) kPa. Connect the transducer to the vacuum outlet located on the intake plenum main vacuum port. Tee the

transducer, manifold absolute pressure sensor and fuel rail pressure regulator all together from the main port.

6.17.2 *Engine Oil Gallery Pressure*—Use a transducer having a range of (0 to 700) kPa. Connect the transducer to the location shown in the Sequence IIIG Engine Assembly Manual, Section 8 Sheet 3 (OUT Port, oil to block).

6.17.3 *Oil Pump Outlet Pressure*—Use a transducer having a range of (0 to 700) kPa. Connect the transducer to the location shown in the Sequence IIIG Engine Assembly Manual, Section 8 Sheet 3 (IN Port, oil to filter).

6.17.4 *Exhaust Back Pressure*—Use a transducer having a range of (0 to 10) kPa; attach the line to the exhaust end plate as shown in the Sequence IIIG Engine Assembly Manual, Section 8 Sheet 1.

6.17.5 *Inlet Air Pressure*—Use a transducer having a range of (–125 to +125) Pa. Connect the transducer to the air inlet adapter as shown in the Sequence IIIG Engine Assembly Manual, Section 8 Sheet 4.

6.17.6 *Crankcase Pressure*—Use a transducer having a range of (–125 to +125) Pa. Connect the transducer to the front of the lower intake manifold as shown in the Sequence IIIG Engine Assembly Manual, Section 6 Sheet 7.

6.18 *PCV Plug*—Block off the positive crankcase ventilation system during testing using a dummy PCV valve, part number OHT3F-002-1, as shown in the Sequence IIIG Engine Assembly Manual, Section 6 Sheet 11.

6.19 *Parts Modifications*—Modify the following parts according to the instructions listed in the Sequence IIIG Engine Assembly Manual:

6.19.1 Throttle body, Section 7 Sheet 6.

6.19.2 Intake manifold, Section 6 Sheet 7.

6.19.3 Engine block, Section 1 Sheet 2.

7. Reagents and Materials

7.1 *Test Fuel*—Use only EEE unleaded fuel^{11,13} (**Warning**—Flammable. Health Hazard.) (see [Annex A4, Table A4.1](#)), observing the following:

7.1.1 Make certain that all tanks used for transportation and storage are clean before filling with test fuel.

7.1.2 Verify that there are at least 3030 L of test fuel.

7.1.3 Analyze quarterly the contents of each storage tank that contains fuel used for qualified Sequence IIIG tests to ensure the fuel has not deteriorated or been contaminated in storage. Analyze the fuel for Distillation, Gravity, RVP Sulfur and Gums. Send the results from these analyses to the TMC for inclusion in the Sequence III Test Fuel data base.

7.2 *Engine and Condenser Coolant*—Use ethylene glycol meeting Specification [E1119](#) for Industrial Grade Ethylene Glycol. (**Warning**—Combustible. Health Hazard.)

7.3 *Coolant Additive*—Use Nacool 2000 or Pencoool 2000 coolant additive^{11,14} for the engine and condenser coolant. (**Warning**—Combustible. Health Hazard. See appropriate MSDS.)

¹³ The sole source of supply of the apparatus known to the committee at this time is Haltermann Products, 1201 Sheldon Road, P.O. Box 429, Channelview, TX 77530-0429.

¹⁴ The sole source of supply of the apparatus known to the committee at this time is Penray Companies, Inc., 1801 Estes Ave, Elk Grove, IL 60007.

7.4 *Coolant Preparation*—Prepare the coolant blend for the engine coolant system, and for the oil cooler and condenser coolant system, in the following manner:

7.4.1 Do not apply heat either during, or following, the coolant preparation.

7.4.2 Use a container of a size adequate to hold the entire coolant blend required by both systems. See drawing RX-117350-D for an example of a suitable container.

7.4.3 Add the required amount of glycol (**Warning**—Combustible. Health Hazard.) to the container.

7.4.4 Add the required amount of additive concentrate to the container to achieve a concentration of coolant additive to glycol of 15.625 mL/L. (**Warning**—See appropriate MSDS.)

7.4.5 Mix the blend in the container for 30 min.

7.4.6 Add the blend to the engine coolant system and the condenser coolant system.

7.5 *Pre-Test Cleaning Materials*—Use the cleaning materials (**Warning**—See appropriate MSDS.) specified in the following list for cleaning of parts to be used in the test. Do not use unapproved substitutes (see **Note 3**).

NOTE 3—Only these specific materials and sources have been found satisfactory. If chemicals other than these are proposed for use, equivalence shall be proven and approval obtained from the TMC.

7.5.1 Use Penmul L460 as the parts cleaning agent.^{11,15} (**Warning**—Corrosive. Health Hazard.)

7.5.2 *Degreasing Solvent*—Use only mineral spirits meeting the specifications for Aromatic Content (0-2 % vol), Flash Point (61 °C, min) and Color (not darker than +25 on Saybolt Scale or 25 on Pt-Co Scale) from Specification **D235** for Type II, Class C mineral spirits. (**Warning**—Combustible. Health hazard.) Obtain a Certificate of Analysis for each batch of mineral spirits from the supplier.

7.5.3 Sequence IIIG Test Component Cleaner, a mixture (by mass) of:

94 parts oxalic acid^{11,16} (**Warning**—Corrosive. Health Hazard.)

6 parts dispersant^{11,17} (**Warning**—Corrosive. Health Hazard.)

NOTE 4—If permitted by the hazardous materials disposal practices in a laboratory, sodium carbonate can be used to neutralize the oxalic acid in used Sequence IIIG Test component cleaner.

7.5.4 Use NAT-50 or PDN-50 soap^{11,18} in automatic parts washers to clean Sequence IIIG engine parts. See **9.3**.

7.6 *Sealing and Anti-seize Compounds*—Use the sealing compounds specified in the following list.

7.6.1 Use Permatex Number 2 non-hardening sealer as the sealing compound for cylinder head bolts.

7.6.2 Use Perfect Seal Number 4 Brush-Type Sealing Compound as the sealing compound for front and rear cover gaskets.^{11,19}

7.6.3 Only GM Autocare Adhesive, part number 12346141, or Dow RTV Grade 3154 sealer and Permatex Ultra Black Sealer, part number 24105, are allowable for use on the oil pan gasket and intake manifold gasket only. (See Sequence IIIG Engine Assembly Manual, Section 4 Sheet 12 and Section 6 Sheet 6.)

7.6.4 The use of Teflon tape is prohibited on the IIIG engine.

8. Test Oil Sample Requirements

8.1 *Selection*—The supplier of the test oil sample shall determine that the test oil sample is representative of the lubricant formulation to be evaluated and that it is not contaminated.

8.2 *Quantity*—The supplier shall provide the test oil sample of 12 L.

NOTE 5—A Sequence IIIG Test can be conducted with a sample of test oil as little as 10 L, provided that no spillage or leakage occur during test preparation. The greater quantity is specified to accommodate minor spillage and leakage.

8.3 *Storage Prior to Test*—The test laboratory shall store the test oil sample in a covered building to prevent contamination by rainwater.

9. Preparation of Apparatus

9.1 *Condenser Cleaning*—Immediately after completing a Sequence IIIG test, remove the stainless steel condenser assembly, disassemble it, and soak it in parts cleaning agent. After the soaking, clean the inside of the tube with parts cleaning agent and a non-cuprous bristle brush. Rinse both the blowby gas and coolant sides of the condenser with clean degreasing solvent.

9.1.1 After ten tests, or more frequently if film is present, clean the coolant side of the condenser by flushing it for one half-hour with a solution of Sequence IIIG test component cleaner at 20 g per 1 L of water. (See **7.5**.) Rinse it thoroughly with tap water at 60 °C.

9.1.2 After cleaning the coolant side of the condenser, pressure check it for leaks using air at 70 kPa.

9.2 *Intake Manifold Cleaning*—Clean the intake manifold with degreasing solvent.

9.3 *Cleaning of Engine Parts (other than the block and heads)*—Clean all engine parts (other than the connecting rods, block and heads; see **9.4**, **9.5** and **9.6**) thoroughly prior to engine assembly. Degrease them first, and then brush them with parts cleaning agent. Immediately remove the cleaner by spraying with hot tap water. Blow-dry the parts with clean, dry shop air (**Warning**—For technical use only) and immediately coat them with a 50/50 mixture of build-up oil and degreasing solvent.

9.4 *Connecting Rod Cleaning*—Clean the connecting rods according to the following:

¹⁵ The sole source of supply of the apparatus known to the committee at this time is Penetone Corporation 74 Hudson Ave. Tenafly, NJ 07670.

¹⁶ The sole source of supply of the apparatus known to the committee at this time is Ashland Chemical Co., P.O. Box 391, Ashland, KY 41114.

¹⁷ The sole source of supply of the apparatus known to the committee at this time is Petro Dispersant Number 425 Powder (50-lb bags) is available from Witco Corp., 3230 Brookfield, Houston, TX 77045.

¹⁸ The sole source of supply of the apparatus known to the committee at this time is Better Engineering Mfg., Inc., 8361 Town Center Court, Baltimore, MD 21236.

¹⁹ The sole source of supply of the product known to the committee at this time is Perfect Seal, 3322 Beekman St., Cincinnati, OH 45223.

9.4.1 Clean the connecting rods by soaking in degreasing solvent for a minimum of 2 h. Spray the rods with a 50/50 mix of build-up oil and degreasing solvent.

9.5 *Engine Block Cleaning*—Clean the block according to the following:

9.5.1 Remove the debris in the head bolt and main bearing-cap bolt holes using class 2B bottoming taps of the appropriate sizes.

9.5.2 Physically remove all sand and slag deposits, and any other debris, from the water jacket using a sharp-ended drill rod or a long straight slot screwdriver.

9.5.2.1 Check the camshaft tunnel for sharp edges on the front of each bore and along the cross-drilled oil gallery inside each bearing bore. Deburr as necessary. See the Sequence IIIG Engine Assembly Manual, Section 1 Sheet 2.

9.5.3 Thoroughly clean the block prior to honing as follows: In the case of a block used in a previous test, remove the crankshaft, main bearings, and bearing caps. In addition, remove all bushings, bearings, and oil gallery plugs prior to cleaning. With either a new or a used block, prevent cleaner or oil from entering the engine coolant passages. (See Sequence IIIG Engine Assembly Manual, Section 1 Sheet 4.)

9.5.3.1 Clean the block in a heated bath or temperature-controlled automated parts washer before and after honing. Follow these suggested guidelines to ensure there is no rusting of the engine block after this process:

(1) Use only NAT-50 or PDN-50 soap at a concentration of 7.3 kg of soap per 380 L of water. Change the soap and water solution at least every six months.

(2) Set the water temperature to 60 °C.

(3) Do not in any manner pre-condition the water that is being used.

(4) Prior to installing the engine in the parts washer, ensure that all coolant passages are blocked off to prevent cleaning solutions from entering the passages.

(5) Allow the block to run through the cleaning cycle for a period of (30 to 40) min.

(6) After the cycle is complete, immediately remove the block from the washer and spray it down with degreasing solvent.

(7) Wipe cylinder bores out with a lint free towel.

(8) Spray engine block with a 50:50 mixture of build-up oil and degreasing solvent.

(9) Do not remove the paint dot from the crankcase area of the block.

(10) Allow the block to cool to room temperature before honing the block.

9.5.3.2 See the Sequence IIIG Engine Assembly Manual, Section 2 for the honing procedure.

9.5.3.3 After honing the cylinder walls, clean the engine block again according to 9.5.3 and spray the engine block (including all oil galleries) first with degreasing solvent followed by a 50:50 mixture of degreasing solvent and build-up oil. Using this 50:50 mixture, wipe out the cylinder bores with clean cloth towels until all honing residue has been removed.

9.5.3.4 Air dry the engine block, using clean dry shop air, and coat the cylinder walls with build-up oil using soft, lint-free, clean cloths.

9.6 *Cylinder Head Cleaning*—Clean the cylinder heads according to the following:

9.6.1 Explore all accessible water passages with a flexible probe to detect any material that would interfere with coolant flow.

9.6.2 Using a 10 mm wire brush, extending two-thirds the length of the cylinder head from freeze plug hole to freeze plug hole, clean all core sand and casting slag from the cylinder heads to ensure unrestrained coolant flow.

9.6.3 Clean the cylinder heads according to the recommended engine block cleaning procedure (see 9.5.3.1) or clean with degreasing solvent. Spray the heads with a 50/50 mix of degreasing solvent and build-up oil. When cleaning the heads, do not remove the paint dot.

9.7 *Engine Build-up Procedure*—Laboratories will maintain engine-build data Sheets as shown in Annex A14. This data shall be available to the TMC and the Test Procedure Developer for investigative studies as deemed necessary for hardware investigations during times of industry severity shifts or other problems.

9.7.1 *General Information*—Use only the listed service parts, special test parts, and special build up procedures specific to this test as outlined in this test method and the Sequence IIIG Engine Assembly Manual. See 6.4. Make and record measurements specified in this test method of the cylinders, pistons, rings, valve train, cam, and lifters. These measurements will provide evidence of conformance to the specifications of the method, and will provide baselines for determining engine wear that occurs during a Sequence IIIG test.

9.7.2 *Special Parts*—Use the special parts listed in the Sequence IIIG Engine Assembly Manual Section 8.

9.7.3 *Hardware Information*—Complete Form 12, Hardware Information, in standardized report form set (see Annex A5).

9.7.4 *Fastener Torque Specifications and Torquing Procedures*—Use the following specifications and torquing procedures when installing bolts in the engine:

9.7.4.1 *Main Bearing Cap Bolts*—Use new main cap bolts on every test, including tests on new engine blocks; do not modify the threads of the bolts. Do not use air tools on bolts to seat the main bearing caps in the engine block. Use a speed handle and socket, in a crisscross pattern to draw down and lightly seat the main cap. Apply build-up oil to the threads and to the surfaces of the bolts that contact the main bearing caps. In order to prevent hydraulic lock, do not apply oil to the tapped holes in the cylinder block. Install the bolts finger-tight and tighten them further with the SPS Torque Sensor I,^{11,20} Ingersoll-Rand ETW-E180,^{11,21} or Snap-on ATECH3FR250 Torque Wrench^{11,22} only, working from the center out in a crisscross pattern. See the Sequence IIIG Engine Assembly

²⁰ The sole source of supply of the apparatus known to the committee at this time is Sunnen Products Co., 7910 Manchester Ave, St. Louis, MO 63143.

²¹ The sole source supply of the apparatus known to the committee at this time is Ingersoll-Rand Assembly Solutions, 510 Hester Drive, White House, TN 37188.

²² Available from local Snap-on dealers. Snap-on is a trademark of Snap-on, Inc., 10801 Corporate Drive, Kenosha, WI 53141-1430.

Manual for torquing instructions. (See Section 1 Sheet 6 for honing and Section 3 Sheet 6 for final assembly.)

9.7.4.2 *Cylinder Head Bolts*—Install the cylinder head bolts, GM Part No. 25527831 (long) and 25533811 (short), which are of special design for yield applications using the SPS Torque Sensor I, Ingersoll-Rand ETW-E180 Torque Wrench, or Snap-on ATECH3FR250 Torque Wrench. See the Sequence IIIG Engine Assembly Manual for installation instructions. Replace the bolts after each test. (See Section 1 Sheet 7 for honing and Section 5 Sheet 3 for final assembly.)

9.7.4.3 *Torques for Miscellaneous Bolts, Studs, and Nuts*—Use the torques for miscellaneous bolts, studs, and nuts given in the Sequence IIIG Engine Assembly Manual.

9.8 *Parts Replacement*—See 9.8.1 for information regarding parts. Replace test parts as follows:

9.8.1 Install the new parts listed in [Annex A2, Table A2.1](#) for each test.

9.8.2 Install the new parts listed in [Annex A2, Table A2.2](#), only if the used part is no longer suitable for test purposes.

9.9 *Engine Block Preparation*—Prepare the engine block as follows:

9.9.1 Install new engine block freeze plugs; use a driver to facilitate this replacement.

9.9.2 Install the main bearing caps, without the bearings in place. Tighten the retaining bolts using the procedure in [9.7.4.1](#).

9.9.3 To prevent entry of honing fluid into the coolant passages of the engine block, cover and seal the coolant inlet passages and freeze plug openings. Close the petcocks if previously installed; if not, install 1/4-in. NPT pipe plugs.

9.9.4 With a 30 cm smoothing file, deburr the surfaces of the block that mate with the cylinder heads to ensure adequate gasket seating.

9.9.5 Use the honing torque plates B-H-J GM 3.8L/3E-Rs_t-HT^{11,23} to pre-stress the engine block for honing. Install the torque plates with the proper hardened washers (supplied with the honing torque plates), single washers on top row and double washers on bottom row, to establish proper bolt depth. Clean the threaded bores for the cylinder head attachment bolts using a bottoming tap before each installation of the torque plates. The torque plates require the use of new head gaskets, SPO Part No. 24503801 left head and 24503802 right head, along with cylinder head, torque-to-yield fasteners, SPO Part No. 25527831 (long). Clean all sealing and thread locking compounds from the fasteners for the torque plate installation. Coat each fastener with build-up oil, and see Section 1 Sheet 7 of the Sequence IIIG Engine Assembly Manual for installation instructions.

9.9.6 Use only the CV-616 honing machine to hone the cylinder walls. See the Sequence IIIG Engine Assembly Manual, Section 2 for all of the proper setup and operational procedures for each specific run on the Sequence IIIG engine block.

9.9.7 Replace the honing fluid, filters, and fiber mats used in the honing machine after every 15-h of honing machine

operation. Use the honing machine hour meter to determine hours of operation. See the Sequence IIIG Engine Assembly Manual, Section 2 Sheet 8.

9.9.8 The flow rate of the honing lubricant should be approximately 7 L/min. In addition, do not introduce solvents into the honing fluid or use them to clean the honing stones or guides. Use only honing fluid to clean honing stones or guides.

9.9.9 Hone the cylinder walls without the main bearings in place, but with all bearing caps installed.

9.9.10 Clean the engine block following honing according to [9.5.3.1](#).

9.9.10.1 Allow the cylinder block to cool for a minimum of 10 min before taking final bore measurements. See Section 2, Sheet 9 of the Sequence IIIG Engine Assembly Manual.

9.9.11 If desired (this is not required), check the main bearing bore clearances using a mandrel, part BX-398-1, according to the following procedure:

9.9.11.1 Starting from the front of the block, slide the mandrel through all four main bearing bores. If excessive resistance is encountered while inserting the mandrel, remove the mandrel from the engine block and inspect the main bearing bores for burrs, nicks, dirt, alignment problems, or any abnormalities. Carefully remove any nicks, burrs, scratches, or dirt with 400-grit paper or a fine stone. Then use a clean shop towel with degreasing solvent to wipe the affected surfaces. Reinstall the mandrel to ensure that it can freely pass through all four main bearing bores. If the mandrel still will not clear the bores after completing the above steps, do not use this block and notify the Test Procedure Developer of the problem. After honing, repeat the above procedure prior to final engine build. The mandrel is an alignment and clearance gage only, not an assembly tool. The mandrel should not be in the bores when installing the main bearing caps or torquing the main bearing bolts.

9.10 *Piston Fitting and Numbering*—Fit the pistons to the cylinders according to recommendations listed in the Sequence IIIG Engine Assembly Manual for the run sequence of the block. Use only the specified code pistons for each run sequence. Number the pistons with odd numbers in the left bank from front to rear and with even numbers in the right bank from front to rear.

9.10.1 *Piston Rings*—The rings are pre-sized for each run; check the gap in the cylinder bore for each test. The top ring gap shall be (0.635 ± 0.051) mm. The bottom ring gap shall be (1.067 ± 0.051) mm. The top ring gap shall be smaller than the bottom ring gap and the difference between the two ring gaps shall be between 0.330 mm and 0.533 mm. If the ring gap difference is below 0.330 mm, contact the Test Procedure Developer. Check the ring gap with a Starrett Ring Taper Gage No. 270 with the ring positioned in the cylinder bore using a piston ring depth gage (drawing RX-118602-B). Position the rings 23.67 mm below the cylinder-block deck surface during gap measurement. Record the top and bottom ring gaps on Form 12, Hardware Information, in standardized report form set (see [Annex A5](#)). Record and report ring gaps in mm.

9.11 *Pre-Test Camshaft and Lifter Measurements*—Measure the camshaft lobe height and lifter lengths, prior to engine assembly, according to the following procedure:

²³ The sole source of supply of the apparatus known to the committee at this time is B-H-J Products Inc., 37530 Enterprise Court, Newark, CA 94560.

9.11.1 Make the camshaft measurement using Mitutoyo Snap Gauge, model 201-152, and a Mitutoyo Digital Indicator, model 543-252B, to measure the camshaft lobes. Make the lifter measurement with a digital indicator equipped with a Mitutoyo 4.3 mm flat tip, model 131-259 mounted in a indicator stand. Equip the indicator stand with a V-block that is rigidly mounted to the base and locates the lifter with its center axis in line with the digital indicator.

9.11.1.1 Use dimensional measuring equipment accurate to 0.01 mm. Before each measurement session, use standards traceable to the National Institute of Standards and Technology, to ensure measuring equipment accuracy. Include standards having length values within 1.3 mm of the typical lifter and lobe measurement taken. Use the same equipment and standards post-test measuring as were used for pre-test measuring. If a calibration shift between the pre-test and post-test measurements is detected, evaluate the shift to determine the effect on the wear measurement. Record the results of the evaluation and any corrective action taken.

9.11.2 With the camshaft positioned in a set of V-blocks, remove any burrs around the outer edge of the camshaft thrust surface, if necessary. Thoroughly clean the camshaft with degreasing solvent to remove all rust preventative coatings and blow-dry it with clean, dry shop air.

9.11.3 Measure the maximum pre-test dimension of each camshaft lobe, transverse to the camshaft axis to the nearest 0.001 mm. This dimension is at the rear edge of all lobe positions (lobes are numbered from the front to the rear of the camshaft). Record the measurements on internal laboratory forms. See 9.7. After measuring, coat the camshaft with build-up oil.

9.11.4 Measure the pre-test length of the lifters at the center of the lifter foot to the nearest 0.001 mm. Record the measurements on internal laboratory forms. See 9.7.

9.11.5 Record the unique serial number for each lifter on internal laboratory forms. See 9.7. Do not use electro-mechanical scribing devices. Do not place any marks on the lifter body or foot.

9.12 *Camshaft Bearing Installation*—The camshaft tunnel is specially processed and uses oversize bearings provided through the CPD. Install the camshaft bearings according to the Sequence IIIG Engine Assembly Manual Section, 3 Sheet 3. Always inspect the lifter and main bearing oil galleries for splintered babbitt materials that might have been shaved from the outside diameter of the bearings during installation. Remove any materials from the oil galleries with clean dry shop air.

9.13 *Camshaft Installation*—Install the camshaft according to the Sequence IIIG Engine Assembly Manual, Section 3 Sheet 11:

9.13.1 Coat the camshaft lobes and journals with a light film of test oil.

9.13.2 Install the camshaft in the engine block, taking care to avoid damage to the lobes, journals, and bearings.

9.13.3 *Installation of Camshaft Thrust Plate*—Lubricate the thrust plate with build-up oil and install the thrust plate to the front of the engine block using new Torx fasteners.²⁴

9.14 *Main Bearings*—Verify that the main bearing bore areas in the engine block and bearing caps are clean. Install new main bearings, part number OHT3F-042-2, in the engine block and main bearing caps, and lightly oil the bearing surfaces with build-up oil. New main bearing cap bolts shall be used for each Sequence IIIG test engine build including a new engine block (discard the bolts the block was machined with).

9.14.1 *Crankshaft*—Install the crankshaft.

9.14.2 *Main Bearing Cap Installation*—Install the main bearing caps using new bolts for each test. Do not use the bolts from the new engine block for the first build; use new fasteners for the first build. Do not remove the phosphate coating from the bolts. Do not use air tools on the main bearing cap bolts to seat the caps. Install the bolts finger-tight, and tighten them according to the procedure in 9.7.4.1. Use the main bearings as received.

9.15 *Crankshaft Sprocket*—Install a matched set two-piece crankshaft sprocket, part number OHT3F-036-1.

9.16 *Camshaft Sprocket, and Timing Chain*—Install a new camshaft sprocket and timing chain.

9.17 *Crankshaft Endplay*—Measure the crankshaft endplay. It should be between (0.076 and 0.279) mm.

9.18 *Piston Pin Installation*—Install new piston pins and retainers for each test. Clean piston pins using a clean lint-free cloth and oil with build-up oil. The piston pins are full floating and held in place by two retainers.

9.18.1 *Piston Installation*—Clean pistons using degreasing solvent and air dry. Wipe the piston with a lint-free towel prior to installation.

9.18.2 Use a piston ring expander to install the pre-gapped piston rings (see 9.10.1) on the pistons.

9.18.3 Position the ring end gaps as shown in the Sequence IIIG Engine Assembly Manual, Section 3 Sheet 8.

9.18.4 Coat the cylinder walls with build-up oil and wipe them with a clean, lint-free soft cloth, repeating the process until clean; apply a final coat of build-up oil before installing the piston assembly.

9.18.5 Coat the pistons and rings with build-up oil.

9.18.6 Install the pistons in the cylinders, using a ring compressor tool.

9.19 *Harmonic Balancer*—Deburr the harmonic balancer key way slot and the slot on the crankshaft with a mill file. On a new balancer, remove the rolled edge on the inside diameter of the balancer so there is a slip-fit on to the crankshaft. Do not install the balancer until after performing the oil pump priming operation in the test stand just prior to test start.

9.20 *Connecting Rod Bearings*—Clean the bearings using a clean lint-free cloth and oil with build up oil prior to installation. Use new connecting rod bearings, part number OHT3F-042-2, for each test, furnished as part of the engine bearing kit.

²⁴ Trademark of Textron Fastening Systems, 840 W. Long Lake Road Suite 450 Troy, MI 48098.

9.20.1 Install the bearings in the connecting rods, and install the bearing caps with the rods in place on the crankshaft.

9.20.1.1 Tighten the connecting rod bolts according to the specifications listed in the Sequence IIIG Engine Assembly Manual. Determine the torque specifications for the connecting rod bolts by the type of connecting rod: cast or powdered metal.

9.21 *Engine Front Cover*—Use a new front cover with each new engine block or if the oil pump gerotor housing is worn. Front covers can be used for as many as six tests. Remove any slag that may be present, and deburr the front cover prior to use.

9.21.1 Install new oil pump gears, or a new front cover and new gears, as deemed necessary according to the Sequence IIIG Engine Assembly Manual inspection requirements Section 4 Sheet 2. Deburr machined surfaces and remove any casting slag in oil passages as necessary.

9.21.2 Install a new oil pump relief valve and spring.

9.21.3 Ensure the oil pump relief valve moves freely inside its bore in the front cover. Check the oil-pump-relief-valve clearance according to the Sequence IIIG Engine Assembly Manual, Section 4 Sheet 4.

9.21.4 Bolt the front cover and oil pump assembly to the engine block.

9.21.5 Inspect the oil pickup tube and screen assembly for cleanliness; install using a new gasket.

9.22 *Coolant Inlet Adapter*—Replace the water pump with a coolant inlet adapter, as shown in drawing OHT3F-031-1.

9.23 *Oil Dipstick Hole*—Plug the oil dipstick hole with a hole-plug (Part OHT3F-065-2). To determine the oil level at the appropriate time during a test, temporarily remove this plug and insert the calibrated dipstick (Part OHT3F-064-2).

9.24 *Oil Pan*—Install the oil pan, part number OHT3F-073-1, on the engine block, using a new gasket. Do not use magnetic drain plugs in the pan.

NOTE 6—Ensure the cut out area of the windage tray/oil pan gasket does not interfere with the oil dipstick and modify if necessary.

9.25 *Cylinder Head Assembly*—Prepare the cylinder heads according to the following procedure:

9.25.1 Install new cup-type freeze plugs.

9.25.2 Deburr all surfaces of the cylinder heads that mate with the engine block and the manifolds with a 30 cm smooth file to ensure satisfactory gasket seating.

9.25.3 Thoroughly clean the cylinder heads according to 9.6 and air blow them dry prior to final assembly. If the automatic parts washer is not used, clean cylinder heads with degreasing solvent and spray with 50/50 solution of build-up oil and degreasing solvent.

9.25.4 Coat the valve stems and valve guides with build-up oil.

9.25.5 Install new valves for each test. Lapping or grinding of valves and/or valve seats is not allowed.

9.25.6 Install new valve stem seals over the valve stems onto the valve guides. Exercise extreme care when installing the seals in order to avoid either cutting the seals or mis-positioning them on the guides, thereby helping to preclude high oil consumption. See Sequence IIIG Engine Assembly Manual, Section 5 Sheet 1.

9.25.7 Install new valve springs, part number OHT3G-059-1 (color code pink). Place the smaller diameter end of the spring against the retainer. Do not remove the factory paint dot from the valve spring.

9.25.8 Install valve retainers and keepers.

9.26 *Adjustment of Valve Spring Loads*—Adjust the load of each valve spring according to the following procedure:

9.26.1 Before and after using the valve spring load measurement apparatus (such as Part BX-310-2), calibrate the load cell using the following technique. Use dead weights to produce the specified load of 912 N.

9.26.1.1 *Load Cell to Load Cell Technique*—Affix load cell weight adapter plate (see Fig. 1) to calibration load cell. Zero the calibration load cell. Individually place calibrated dead weights onto calibration load cell. Verify that each dead weight indicates the appropriate load on calibration transducer read-out. Repeat the calibration of the calibration load cell. The two consecutive readings shall agree within 2.2 N; if not, inspect the load cell and replace as necessary. Align calibration load cell beneath apparatus load cell. Place the air cylinder ram on the calibration load cell. Set the apparatus load cell to read the value of the calibration load cell. Apply air pressure to the aligned load cells. Vary air pressure to give several different loads, including 801 N. Determine that both calibration and apparatus transducer readouts indicate the same value, if not, adjust the apparatus load cell. Repeat the calibration of the valve-spring load-measurement apparatus. The two readings shall agree within ± 2.2 N; if not, inspect the apparatus load cell and replace if necessary. Retain data obtained during each calibration.

9.26.2 Install a cylinder head in the holding fixture. The holding fixture shall position the cylinder head such that the valve is directly in line with the air cylinder-loading unit and no side loading of the valve takes place.

9.26.3 Install Zeroing Fixture, Part D4031, to cylinder head. Zeroing fixture, Part D4031, is part of the valve-spring load-measurement apparatus, Part BX-310-2.

9.26.4 Place the air cylinder-loading unit over a valve and check for proper alignment of the valve tip with the loading unit.

9.26.5 Position the dial indicator and its foot on the zeroing fixture to facilitate accurate measurement of valve stem axial movement.

9.26.6 Rapidly apply and release the air pressure three times to ensure free travel of the piston rod; adjust the air pressure to obtain a valve deflection reading of 9.5 mm, if necessary.

9.26.7 If the readings are not within the specifications of (912 ± 44) N load as shown by the load cell indicator, add or remove shims, or interchange parts as necessary.

9.26.8 Repeat steps 9.26.2 through 9.26.7.

9.27 *Cylinder Head Installation*—Use new head gaskets for each application. Do not use any sealers on the cylinder head gaskets. Use new fasteners for each application. Before using the fasteners for cylinder head attachment, remove all pre-coat sealers. Remove thread locking compounds from the threads and underside of the bolt head with a wire wheel or brush. Do not use chemical cleaners to remove these coatings. Coat the threads and underside of the bolt head using non-hardening

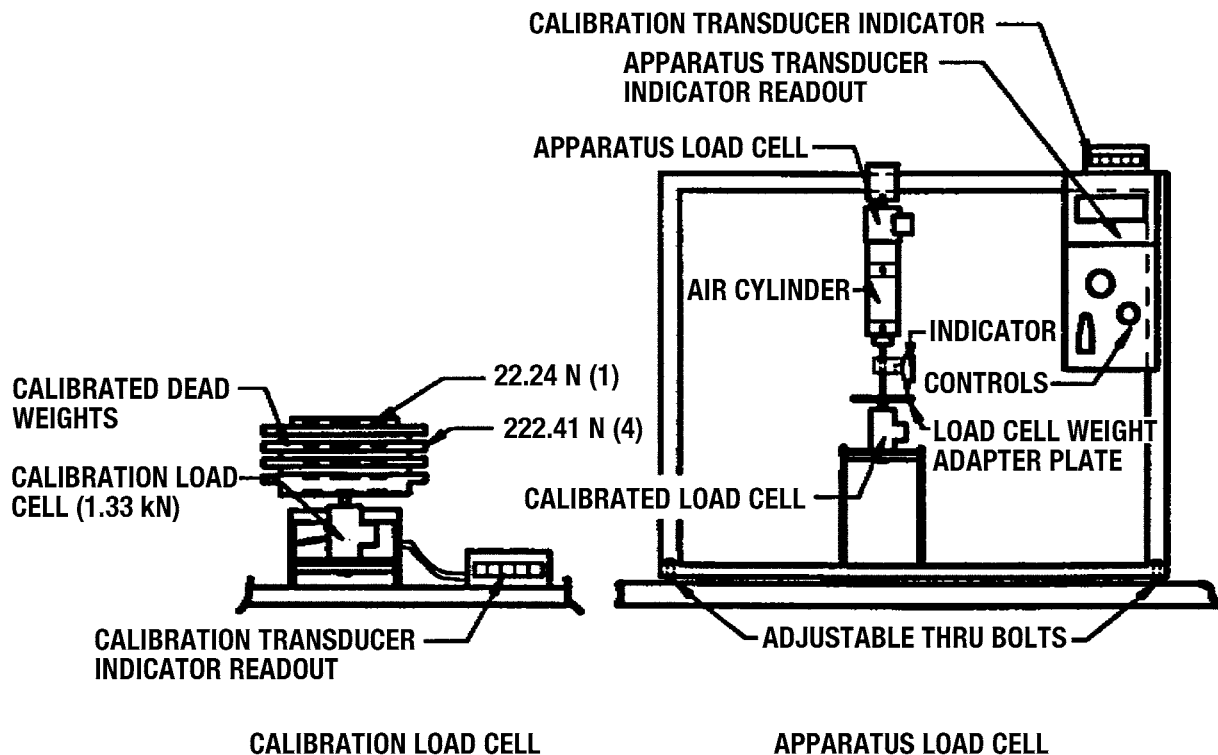

FIG. 1 Load Cell-to-Load Cell Calibration Method Diagram

pliable sealing compound. Tighten the fasteners according to the guidelines in the Sequence IIIG Engine Assembly Manual, Section 5 Sheet 3.

9.28 *Hydraulic Valve Lifters*—Do not open the hydraulic lifter to expose any part of the internal parts. Do not remove the factory-installed leak down oil. Do not use electro-mechanical or chemical means to etch identification numbers on the hydraulic lifters.

9.28.1 Prior to installation, clean the lifter body and foot using a clean cloth dampened with degreasing solvent. Do not submerge or spray the hydraulic lifter. Gently wipe the lifter body with the solvent-dampened cloth and dry using a clean dry cloth or terry towel.

9.28.2 Install the test lifters in the test engine, coating each lifter foot with test oil before installation into the lifter bore. Rotate the engine crankshaft slowly for 720° while ensuring that the lifters follow the cam lobe profile. Remove each lifter and once again coat the lifter foot with test oil. Reinstall the lifter into the engine block with the ground flat on the lifter body facing inboard toward the center of the engine. See the Sequence IIIG Engine Assembly Manual, Section 6 Sheet 1.

9.28.2.1 Use a test oil sample of 118 mL to lubricate the cam and lifters during engine assembly. Pour any remaining oil into the lifter valley of the engine after this process is complete.

9.29 *Pushrods*—Clean the pushrods with degreasing solvent and air blow them dry prior to installation; make certain that the oil passages are open. Wipe the pushrods with a lint-free cloth prior to installation. Lubricate the ball ends of the pushrods with buildup oil and install the pushrods. See the Sequence IIIG Engine Assembly Manual, Section 6 Sheet 2.

9.30 *Valve Train Loading*—Install the rocker arm pivot retainer and the precision roller rockers and torque the rocker arm pedestal bolts according to the Sequence IIIG Engine Assembly Manual, Section 6 Sheet 4. Rocker arm pivot retainers can be used for up to six tests before being replaced.

9.30.1 Once the valve train is loaded, do not rotate the engine until using the dynamometer air starter system at the start of test.

9.31 *Intake Manifold*—Modify the intake manifold as shown in the Sequence IIIG Engine Assembly Manual, Section 6 Sheet 7.

9.31.1 Plug the EGR port using part number OHT3F-024-1.

9.31.2 Install the positive crankcase ventilation valve, replacement plug (part number OHT3F-002-1) in the intake manifold plenum.

9.32 *Rocker Covers*—Install two left-side rocker covers part number 25534751 on the cylinder heads.

9.33 *Water Outlet Adapter*—Install a water inlet adapter made according to drawing OHT3F-034-1.

9.34 *Condenser*—Install a condenser mounting bracket, part number OHT3F-041-1, and condenser, part number BX-212-1 or OHT3F-075-1, with an adapter, part number OHT3F-040-1, on the front of the engine using flexible hose to connect the adapter to the rocker cover bushings, part number OHT3F-028-1.

9.35 *Coolant Outlet Adapter*—Replace the thermostat housing with a coolant outlet adapter, part number OHT3F-034-1.

9.36 *External Oil Cooling System*—Install the external cooling system as follows:

9.36.1 Install a modified Oil Filter Engine Adapter, part number OHT3F-080-1, refer to Section 4 Sheet 4 and Section 8 Sheet 3a of the Sequence IIIG Assembly Manual. Install the adapter on the engine front cover.

9.36.2 Install an Oil Cooler, part number OHT3F-030-2, using Connector part number OHT3F-039-3, as shown in the Sequence IIIG Engine Assembly Manual, Section 8 Sheet 3.

9.36.3 Install an Oil Filter Adapter Fitting, part number OHT3F-043-2, and an Oil Filter Adapter, part number OHT3F-035-2, as shown in the Sequence IIIG Engine Assembly Manual Section 8 Sheet 3.

9.36.4 Install the Bypass Valve Assembly Housing, part number OHT3F-084-1, on the Oil Filter Engine Adapter, as shown in the Sequence IIIG Engine Assembly Manual Section 8 Sheet 3.

9.37 *Oil Sample Valve*—Install suitable plumbing to the oil pressure fitting located in the oil filter adapter to permit the removal of oil samples. Select the plumbing to minimize the added volume.

9.38 *Ignition System*—Install ignition system components according to the following instructions:

9.38.1 Use high-energy ignition wires which are resistant to moisture and high temperatures.

9.38.2 Use an original equipment manufacturer coil pack mounted on the front engine mount according to drawing OHT3F-026-1.

9.38.3 Use new spark plugs; NGK part number TR-6, stock number 4177. Adjust the gaps with a wire gage to 1.14 mm. Install a set of plugs prior to test start-up. Tighten spark plugs hand-tight plus $\frac{1}{16}$ turn.

9.39 *Throttle Body*—Modify a production throttle body according to the drawing in the Sequence IIIG Engine Assembly Manual, Section 7 Sheet 6.

9.39.1 Install the throttle body onto the plenum and attach the throttle body adapter, part number OHT3F-001-2.

9.40 *Accessory Drive Units*—Do not use any accessory drive units, such as alternators, generators, fuel pumps, power steering units, air pumps, and so forth.

9.41 *Exhaust Manifolds, Water-Cooled*—Prepare two water-cooled exhaust manifolds, part number OHT3F-003-1, and install one on each of the two cylinder heads using transition adapters, part number OHT3F-004-1, according to the following instructions:

9.41.1 Deburr all the surfaces of the exhaust manifolds that mate with the cylinder heads with a 30 cm smooth-cut file to ensure proper gasket seating.

9.41.2 Attach the exhaust manifolds to the heads using stainless steel studs ($\frac{3}{8}$ -16 by $\frac{3}{8}$ -24 by $1\frac{1}{2}$ in.), stainless steel $\frac{3}{8}$ -24 nuts, and shielded exhaust gaskets, part number OHT3F-018-1 or GM 24506009.

9.41.3 Ensure that there are no leaks between the manifold assembly components that might allow outside air to enter the exhaust system through scavenging upstream of the O_2 sensor.

9.42 *Engine Flywheel*—Install the flywheel and drive shaft plate assembly OHT3F-020-2.

9.43 *Pressure Checking of Engine Coolant System*—If desired, pressure-check the engine coolant system after assembly

and before installation of the engine on the test stand, according to the following procedure:

9.43.1 Block all coolant outlets, and install the necessary fittings on the coolant inlet to permit pressurizing the coolant system with air, and sealing it.

9.43.2 Pressurize the coolant system with air to 100 kPa, and seal it. Monitor the pressure for 10 min. Take no corrective action if the reduction in pressure is less than 3.4 kPa in 10 min. If larger changes in pressure occur, re-torque all appropriate bolts, and replace gaskets, seals, and components (including the cylinder heads and the intake manifold) as necessary. Repeat the pressure checking.

9.44 *Lifting of Assembled Engines*—Lift the assembled engines with a suitable lift chain.

9.45 *Mounting the Engine on the Test Stand*—Mount the engine on the test stand according to the following:

9.45.1 Use OHT3F-026 front and OHT3F-025 rear engine mounts.

9.45.2 Mount the engine in such a manner that the intake plenum mounting flange-to-intake manifold interface is horizontal.

9.45.3 Install an engine flywheel guard, safety housing, and air starter mounting assembly (part of OHT3F-025).

9.45.4 Connect the engine to the dynamometer with a flywheel-to-driveshaft coupling adapter (part of OHT3F-020-1) and a driveshaft.

9.45.5 Install a coolant drain valve in the middle of each side of the block, in the $\frac{1}{4}$ -in. NPT hole. The use of street ells and petcocks are satisfactory. Petcocks shall remain as installed for the remainder of the test.

9.46 *External Cooling System Cleaning*—Clean the external cooling system of either a new or used test stand, or a new flushing tank assembly. Clean the used test stand system periodically, typically before a reference test. Use the following procedure:

9.46.1 Prepare a cleaning mixture in the flushing tank (drawing RX-116924-C) by mixing Sequence IIIG test component cleaner (**Warning**—Corrosive. Health Hazard.) at 19 g per 1 L of water (see 7.4). Heat the mixture to $(60 \pm 2.8)^\circ\text{C}$.

9.46.2 Circulate the mixture at 160 L/min flow rate for 30 min.

9.46.3 Immediately following step 9.46.2, thoroughly flush all system components with water at $(60 \pm 2.8)^\circ\text{C}$.

9.46.4 Ensure that all low points in the system are drained after cleaning.

9.47 *Engine Coolant Jacket (Flushing)*—After installing the engine on the test stand, chemically clean the engine coolant jacket to ensure the proper rate of heat transfer to the jacket coolant, according to the following procedure:

9.47.1 Connect the flushing tank to the engine so that the cleaning solutions enter at the coolant outlet adapter and exit at the front of the engine block (reverse flow only for flushing) through the water inlet adapter.

9.47.2 Connect the coolant outlet hose located at the front of the engine intake manifold to the flush cart return for this procedure.

9.47.2.1 Equip the coolant outlet hose connection at the intake manifold with a suitable ½-in. ball valve. Close this valve during the flushing portion of the procedure using the Sequence IIIG Test Component Cleaner. Open the valve during the water rinse portion of the procedure.

9.47.3 For the following segments of this cleaning procedure, minimize the elapsed time between steps in order to avoid rusting of the coolant jacket.

9.47.4 Remove the oil pan drain plug. Open the engine block petcocks and pass hot water (60 to 70) °C through the engine coolant jacket for 2 min. Check for coolant leaks around the intake manifold, front cover, rear cover, and oil pan drain plug. If coolant is leaking, take appropriate steps to stop the leak. If no leaking is evident, close the petcocks and fill the flushing tank and engine block with water to provide a total volume of (38 to 45) L.

9.47.5 Energize the flushing tank heaters. Circulate water through the engine at a flow rate of (115 to 130) L/min through the engine until the temperature of the water flowing out of the engine reaches (70 ± 3.0) °C. Isolate the engine from the flush cart.

9.47.6 While the flush cart is isolated from the engine with water still circulating, add Sequence IIIG test component cleaner at 19 g/L of water (see 7.5.3) to the water in the flushing tank. Continue to circulate the mixture in the flush cart for 3 to 5 min.

9.47.7 Circulate the mixture through the engine for 30 min.

9.47.8 Stop the circulation pump, open the engine block petcocks, and drain the contents of the engine and flushing tank into a suitable container (see Note 7).

NOTE 7—Before disposal, the drained material should be neutralized according to applicable local and federal hazardous material guidelines.

9.47.9 Open the ball valve on the coolant outlet hose on the intake manifold. With the engine block petcocks closed, flow hot tap water through the engine and flush cart system for (2 to 5) min. The water flowing through the engine during this step shall make a single pass through the engine and flush cart. Continue flowing water through the engine until the pH of the water flowing out of the engine is neutral. Check the pH of the rinse water at the return port in the flush tank (see Note 7).

9.47.10 Immediately after neutralizing the engine block in 9.47.9, open the block petcocks and drain all flush water.

9.47.11 Disconnect the flush cart plumbing and remove any trapped water in the intake manifold plumbing by blowing compressed air through the coolant outlet on the rear of the engine block.

9.47.12 Connect the engine to the external engine cooling system.

9.47.13 Immediately charge the engine jacket with coolant.

9.48 *Coolant Charging*—Charge the engine jacket with the specified coolant (see 7.4) according to the following procedure:

9.48.1 To preclude contamination of the coolant system with water, install low-point drains and eliminate all traps in the system. Drain all water in the system.

9.48.2 Use a charging adapter installed between the external cooling system and the engine.

9.48.3 Completely fill the engine jacket and cooling system with coolant (see 7.3). Fill the engine coolant jacket before filling the condenser system.

9.48.4 Charge the condenser coolant system immediately after charging the engine cooling system.

9.48.5 Operate the circulating pumps to aid in the removal of air and consequently decrease the time to achieve clarity of the coolant. During this period, operate any proportioning valves in the coolant system several times.

9.48.6 Until the test is started, circulate the coolant at a temperature of (48.9 ± 2.8) °C and a flow rate of 160 L/min. Start the test no later than 6 h after step 9.48.5.

9.49 *Test Oil Charging*—Charge the engine with the test oil as follows:

9.49.1 Install a new oil filter OHT3F-057-3.

9.49.2 Add an initial fresh test oil fill of 5.50 L through the rocker-cover oil-fill cap using a flask that is calibrated to Class A standards, via a National Institute of Standards and Technology (NIST) traceable standard.

9.50 *Engine Oil Pump Priming*—Prime the engine oil pump according to the following instructions:

9.50.1 With the harmonic balancer and front half of the oil pump drive gear OHT3F-036-1 removed, use a suitable high torque drill motor rated at (7 to 9) A at 2400 r/min (no load) for driving the oil pump drive tool OHT3F-038-1 rotating the gerotor oil pump in a clockwise direction (viewed from the front of the engine) for 2 min after indication of oil pressure. The Dewalt model DW515 has been found suitable for this application.

9.50.2 Replace the front half of the oil pump drive gear and the harmonic balancer and torque the harmonic balancer to 150 N·m + 76°.

9.50.3 Connect the crankcase pressure line and oil sample valve fittings in preparation for testing, and proceed with the initial run (see 11.14).

10. Calibration

10.1 *Laboratory and Engine Test Stand Calibration*—To maintain testing laboratory and engine test stand calibration status for Sequence IIIG engine oil testing, follow the procedures given in 12.13 and Annex A1.

NOTE 8—Section 12.13 and Annex A1 describe the involvement of the TMC in respect to calibration procedures and acceptance criteria for a testing laboratory and a test stand, and the issuance of Information Letters and memoranda affecting the test method.

NOTE 9—A stand can be IIIG calibrated in accordance with this test method and IIIF calibrated in accordance with Test Method D6984. A stand that was IIIF or IIIG calibrated within the previous year can be calibrated as both a IIIF and IIIG stand. If the stand was not IIIF or IIIG calibrated within the past year, follow the LTMS guideline for new stand requirements to obtain IIIF or IIIG calibration.

10.2 *Testing of Reference Oils*—Periodically conduct tests on reference oils according to the following:

10.2.1 Conduct reference oil tests on each calibrated test stand within a laboratory according to ASTM Test Monitoring Center²⁵ guidelines.

10.2.2 Obtain reference oils directly from the TMC. These oils are formulated or selected to represent specific chemical types or performance levels, or both. They are usually supplied directly to a testing laboratory under code numbers to ensure that the laboratory is not influenced by prior knowledge of acceptable results in assessing the test results. The TMC will determine which specific reference oil the laboratory shall test.

10.2.3 Unless specifically authorized by the TMC, do not analyze reference oils, either physically or chemically. Identification of reference oils by such analyses could undermine the confidentiality required to operate an effective reference oil system. Therefore, reference oils are supplied with the explicit understanding that they will not be subjected to analyses other than those specified in this procedure, unless specifically authorized by the TMC. If so authorized, prepare a written statement of the circumstances involved, the name of the person authorizing the analysis, and the data obtained; furnish copies of this statement to both the TMC and the Test Procedure Developer.

10.2.4 Assign a stand test number to each Sequence IIIG test. The number shall include the stand number, the number of Sequence IIIG tests conducted on the stand since the last reference oil test was conducted (0 to 15), and a sequential laboratory test number based on the starting date of the test. For example, 60-03-785 defines a Sequence IIIG test on stand number 60, which is the third non-reference oil test run on stand 60 since successful completion of a reference oil test, and was the 785th Sequence IIIG test in the laboratory. The only exception to this format is that the sequential laboratory test number shall have the letter A appended for the first rerun, B for the second, and so forth, for invalid or unacceptable reference oil tests. The laboratory test number shall still be increased on tests receiving a letter suffix on the lab run number. For example, if test number 60-0-100 was aborted and the next sequential laboratory run number at the time the rerun is started is 108, the test number for this rerun would be 60-0-108A.

10.3 *Reference Oil Test Frequency*—Conduct reference oil tests according to the following frequency requirements:

10.3.1 Conduct reference oil testing according to the guidelines published in the Lubricant Test Monitoring System, available from the ASTM TMC.

10.3.2 After the laboratory reference oil test is started, non-reference oil tests may be started in any other calibrated test stands.

10.3.3 Reference oil test frequency may be adjusted due to the following reasons:

10.3.3.1 *Procedural Deviations*—On occasions when a laboratory becomes aware of a significant deviation from the

test method, such as might arise during an in-house review or a TMC inspection, the laboratory and the TMC shall agree on an appropriate course of action to remedy the deviation. This action may include the shortening of existing reference oil calibration periods.

10.3.3.2 *Parts and Fuel Shortages*—Under special circumstances, such as industry-wide parts or fuel shortages, the surveillance panel may direct the TMC to extend the time intervals between reference oil tests. These extensions shall not exceed one regular calibration period.

10.3.3.3 *Reference Oil Test Data Flow*—To ensure continuous severity and precision monitoring, calibration tests are conducted periodically throughout the year. There may be occasions when laboratories conduct a large portion of calibration tests in a short period of time. This could result in an unacceptably large time frame when very few calibration tests are conducted. The TMC can shorten or extend calibration periods as needed to provide a consistent flow of reference oil test data. Adjustments to calibration periods are made such that laboratories incur no net loss (or gain) in calibration status.

10.3.3.4 *Special Use of the Reference Oil Calibration System*—The surveillance panel has the option to use the reference oil system to evaluate changes that have potential impact on test severity and precision. This option is only taken when a program of donated tests is not feasible. The surveillance panel and the TMC shall develop a detailed plan for the test program. This plan requires all reference oil tests in the program to be completed as close to the same time as possible, so that no laboratory/stand calibration is left in an excessively long pending status. In order to maintain the integrity of the reference oil monitoring system, each reference oil test is conducted so as to be interpretable for stand calibration. To facilitate the required test scheduling, the surveillance panel may direct the TMC to lengthen and shorten reference oil calibration periods within laboratories such that the laboratories incur no net loss (or gain) in calibration status.

10.3.4 *Donated Reference Oil Test Programs*—The Surveillance Panel is charged with maintaining effective reference oil test severity and precision monitoring. During times of new parts introductions, new or re-blended reference oil additions, and procedural revisions, it may be necessary to evaluate the possible effects on severity and precision levels. The surveillance panel may choose to conduct a program of donated reference oil tests in those laboratories participating in the monitoring system, in order to quantify the effect of a particular change on severity and precision. Typically, the surveillance panel requests its panel members to volunteer enough reference oil test results to create a robust data set. Broad laboratory participation is needed to provide a representative sampling of the industry. To ensure the quality of the data obtained, donated tests are conducted on calibrated test stands. The surveillance panel shall arrange an appropriate number of donated tests and ensure completion of the test program in a timely manner.

10.3.5 Under special circumstances, such as extended downtime caused by industry-wide parts or fuel shortages, the TMC may extend the intervals between reference oil tests.

²⁵ ASTM Test Monitoring Center, System Time Response Measurement Guidelines, 5/27/998. Available at internet address: ftp://ftp.astmtmc.cmu.edu/docs/quality_index_and_data_acquisition/TMC%20System%20Time%20Response%20Measurement%20Guidelines.pdf

10.4 *Reporting of Reference Oil Test Results*—Report the results of all reference oil tests to the TMC according to the following directives:

10.4.1 Transmit results to the TMC within 5 days of test completion via electronic data transfer protocol as outlined in the Data Communication Committee, Electronic Test Report Transmission Model (ETRTM). The ETRTM can be obtained from the TMC.

10.4.2 If the test was conducted during a time extension permitted by the TMC, it should be indicated in the Comments Section of the test report.

10.4.3 For an acceptable reference oil test, conducted following an unacceptable reference oil test. Provide sufficient information in the Comments Section of the test report to indicate how the problem was identified and corrected, insofar as possible, and how it was related to non-reference oil tests conducted during the period of time that the problem was being solved.

10.4.4 Report the results on final standard report forms supplied by the TMC, which can be obtained from the TMC web site: <ftp://ftp.astmtmc.cmu.edu/datadict/> or by contacting the TMC (see 10.4.4.1).

10.4.4.1 In timely fashion, mail one copy of the standard final report to the Test Procedure Developer, and one copy to the TMC Test Report Clerk to be received within 30 days of test completion. Mail reports to the following addresses:

Test Procedure Developer:
 General Motors Corporation
 Engine Engineering Building
 Mail Code 483-730-322
 Sequence IIIG Test Coordinator
 823 Joslyn Road
 Pontiac, MI 48340-2920

Test Report Clerk:
 Test Report Clerk
 ASTM Test Monitoring Center
 6555 Penn Avenue
 Pittsburgh, PA 15206

10.5 *Evaluation of Reference Oil Test Results*—The TMC will evaluate the reference-oil test results for both operational validity and statistical acceptability. The TMC may consult with the Test Procedure Developer, and test laboratory in case of difficulty, as follows

10.5.1 Immediately upon receipt of the reference-oil test results from the test laboratory, the TMC will evaluate the laboratories decision on operational validity. For operationally valid tests, the TMC will then evaluate the pass/fail parameters according to the Sequence IIIG The Lubricant Test Monitoring System (TMC Memorandum 94-200). If the test is judged acceptable, the reference oil code will be disclosed by the TMC to the test laboratory. The TMC will convey its preliminary findings based on the limited information available to them, to the test laboratory.

10.5.2 Subsequently, upon receipt of the information detailed in 10.4.4, the TMC will review all reference-oil test results and reports to determine final test acceptability.

10.5.3 In the event the reference oil test is unacceptable, the test laboratory shall provide an explanation of the problem relating to the failure. If the problem is not obvious, all test-related equipment shall be re-checked. Following this re-check, the TMC will assign another reference oil for testing by the laboratory.

10.5.4 The TMC will decide, with consultation as needed with industry experts (testing laboratories, Test Procedure Developer, members of the ASTM Technical Guidance Committee and of the Surveillance Panel, and so forth.), whether the reason for any failure of a reference oil test is a false alarm, testing stand, testing laboratory, or industry-related problem. The Sequence IIIG Surveillance Panel shall adjudicate all industry problems.

10.6 *Status of Non-Reference Oil Tests Relative to Reference Oil Tests*—Non-reference oil tests may proceed within a given laboratory during reference oil testing based upon the following:

10.6.1 During the time of conducting a reference oil test on one test stand, non-reference oil tests may be conducted on other previously calibrated stands. If the reference oil test is acceptable to the TMC, the non-reference oil tests shall be considered to have been run in a satisfactorily calibrated laboratory.

10.6.2 If a reference oil test is unacceptable, and it is determined that the problem is isolated to an individual test stand, other test stands will be considered to remain calibrated, and testing of non-reference oils may proceed on those other stands.

10.6.3 If a reference oil test is unacceptable, and it is determined that the problem is laboratory related, non-reference tests running during the problem period shall be considered invalid unless there is specific evidence to the contrary for each test.

10.7 *Status of Test Stands Used for Non-Standard Tests*—If a non-standard test is conducted on a previously calibrated test stand, conduct a reference oil test on that stand to demonstrate that it continues to be calibrated, prior to running standard tests.

10.8 *Data Acquisition and Control*—The Sequence IIIG test requires the use of computerized data acquisition and control for all measured and controlled parameters outlined in this procedure. The system chosen by individual testing laboratories shall be capable of integrating with the Sequence IIIG Process Controller for many of these operations. The system shall also be capable of meeting or exceeding certain test specific performance requirements for maximum allowable response times and minimum allowable sample rates. In addition to the aforementioned requirements, the system shall also be capable of data logging to test specific archival files for each test parameter at minimum allowable record intervals, that is, no greater than two-minute intervals between successive logs for each parameter. See the Data Acquisition and Control Automation II Task Force Report (DACA II)²⁶ and additional requirements as outlined in this procedure.

²⁶ *Data Acquisition and Control Automation II Task Force Report, 6/17/97*, is available at internet address: ftp://ftp.astmtmc.cmu.edu/docs/quality_index_and_data_acquisition/DACA_II_Report.pdf

10.8.1 *Sample Rate*—The preferred sample rate is 100 Hz with the minimum allowable sample rate for the Sequence IIIG data acquisition and control system set at 1 Hz.

10.8.2 *Measurement Accuracy*—All measurement devices used for sensing speed, load, flow, pressure, and temperature shall meet the minimum requirements as outlined in the DACA II report and also conform to total system response requirements as outlined by the TMC. The following is a list of minimum requirements for Sequence IIIG testing:

10.8.3 *Temperature*—Use only Specification E608/E608M, iron-constantan (Type J) thermocouples with an accuracy of ± 0.5 °C over a range of (0 to 200) °C.

10.8.4 *Pressure*—For pressures >6.9 kPa, use only measuring devices with an accuracy of ± 0.2 % of full scale for capacitive systems and ± 0.25 % of full scale for strain-type systems. For pressures <6.9 kPa, use only devices with an accuracy of ± 15 Pa for capacitive systems and ± 14 Pa for strain-type systems.

10.8.5 *Flow*—For systems incorporating vortex shedding measuring (liquid) use ± 0.75 % of reading; for vortex shedding measuring (gas); use ± 3.0 % of full scale. For magnetic measurements, use ± 1.0 % of reading; for Coriolis measurements use ± 0.75 % of reading.

10.8.6 *Speed*—For speeds measured by frequency, use ± 1 r/min.

10.8.7 *Load*—For loads measured by strain gage, use ± 0.25 % of full scale.

10.8.8 *Measurement Resolution*—The minimum resolution for all parameters shall be at least $\frac{1}{4}$ the required system accuracy for that parameter, that is, if a test procedure requires an accuracy of 1.0 units, then the minimum resolution for that parameter = 0.25 unit.

10.8.9 *System Time Response*—Total system time response is the time required for the complete data acquisition system including all filtering, transducer lines, and surge tanks to measure a step change input for a given parameter. Determine system response times by measuring the time required to reach a certain percentage of an imposed step change. For first order systems, use the time to 63.2 % of the imposed step change; for moving average systems use the time to 45.4 % of the imposed step change.

10.8.9.1 See the TMC System Time Response Measurement Guidelines for methods of imposing step changes for calibration of Sequence IIIG test stands.

10.8.9.2 See Annex A8 for maximum allowable system time responses for the data acquisition system.

10.8.10 *Quality Index*—Use of the quality index method of measuring the control capability of the test stand is required for certain parameters. The following formula should be used and a minimum of 2400 data records are required for the final, end-of-test values:

$$QI = 1 - \frac{1}{n} \sum \left(\frac{U + L - 2X_i}{U - L} \right)^2 \quad (1)$$

where:

QI = quality index,

X_i = recorded test measurement parameter,

U = upper specification limit for that parameter,

L = lower specification limit for that parameter, and
 N = total number of data points taken as determined from test length and procedural specified sampling rate.

10.8.10.1 The upper and lower values used for QI calculations for the required parameters are listed in Annex A7.

10.8.11 Calibrate the stand instrumentation used for data acquisition and control, on all controlled and non-controlled parameters (see Annex A7), every six months.

10.8.11.1 At a minimum, calibrate the following parameters prior to every reference test sequence, unless the required six-month calibration was completed within 60 days prior to reference test start; engine speed, dynamometer torque, engine coolant out thermocouple, oil filter block thermocouple.

10.8.11.2 If a test stand is calibrated in both the IIIF and IIIG test methods, conduct stand instrumentation calibrations as defined in 10.8.11.1 every 15 test starts.

10.8.11.3 Calibrate the intake air-humidity system every six months, at a minimum.

11. Engine Operating Procedure

11.1 *Dipstick and Hole Plug*—Remove the calibrated dipstick and close off the dipstick hole in the block with the required plug, for all engine operation. See the Sequence IIIG Engine Assembly Manual, Section 1 Sheet 2.

11.2 *Dipstick Hole O-ring*—Periodically replace the O-ring on the dipstick hole plug, part number 2-106, to ensure a good seal between the plug and the engine block.

11.3 *Engine Start-up and Shutdown Procedures*—Start and stop Sequence IIIG engines according to the following procedures and the test states and set points listed in Annex A7.

11.4 *Start-up*—Use the following procedure in starting Sequence IIIG engines:

11.4.1 Before cranking engine, supply (13 to 15) V dc power to the Powertrain Control Module, fuel pump, and all AFR control units for a minimum of 30 s to assure all systems are prepared for closed loop AFR control. The lambda sensors are pre-heated and ready for closed-loop control when the AFR readings are over 20:1 prior to engine start.

11.4.2 Simultaneously, start the coolant flowing through the exhaust manifolds.

11.4.3 If the engine fails to start after 5 s, determine the problem and take corrective action taken before any further attempts are made. Make a log entry of any failed attempt and any corrective action in the test report.

11.4.4 After starting the engine, verify that oil pressure is adequate, and the speed is set to 1500 r/min and the load to 6.34 kW.

11.5 *Scheduled Shutdown*—Use the following procedure in stopping Sequence IIIG engines:

11.5.1 Reduce the engine speed and load to 1500 r/min and 6.34 kW with a linear ramp-down over 30 s (if applicable). Within 90 s, remove the required oil purge sample and analysis sample of 472 mL (see 11.7) from the engine oil sampling valve and adjust all temperatures for engine shutdown.

11.5.1.1 Prior to shutdown on the initial run and at the end of test, add the 472 mL purge back to the engine.

11.5.1.2 Prior to shutdown on all oil levels except the initial and the end of test, add the 472 mL of new oil, plus an additional 59 mL of new oil to the engine prior to shutdown.

11.5.2 Turn off power to the Powertrain Control Module (PCM).

11.5.3 With the engine stopped, stop the coolant flow through the exhaust manifolds and continue with the oil sampling and leveling procedure (see 11.7 through 11.8.7).

11.6 *Non-Scheduled Shutdowns*—For any non-scheduled shutdowns, record in detail the time off test, the reasons for the shutdown and any other pertinent observations. Include this record in the test note Section of the final test report.

11.7 *Oil Sampling*—With the engine running at 1500 r/min, remove all oil samples from the engine oil sampling valve according to the following instructions:

11.7.1 Before taking the samples in each of the following steps, first remove a purge or leveling sample of 472 mL; then remove the oil sample of the specified volume.

11.7.2 Take an analysis sample of 236 mL at the end of the initial run (identified as the initial sample) and at the end of the 100 h test.

11.7.3 Take a 59 mL sample at the end of every 20 h during the test, except at the end of the 100th hour when taking an end-of-test sample of 236 mL.

11.8 *Oil Leveling*—Determine the oil level in the crankcase according to the following instructions:

11.8.1 Determine the oil level after the initial run of 10 min and after each 20 h of test.

11.8.2 Stop the engine according to the procedure in 11.5 for 15 min to allow the oil to return to the crankcase.

11.8.3 During the oil-leveling period of 20 min, maintain the condenser temperature at 40 °C and the engine coolant temperature at 49 °C.

11.8.4 Determine the oil level after the 15 min period, in millimetres, using the calibrated dipstick (see Annex A3).

11.8.5 Following the initial run, record the oil level on Fig. A9.1, according to 11.8.6. Use this level as the full mark for the test. Enter zero millilitres as the computed oil level on Fig. A9.1.

11.8.6 After each 20 h of the 100 h test, except at the end of test, add 59 mL of new oil to replace the sample taken; also add 472 mL of new oil to the engine.

11.8.7 After each 20 h of the 100 h test, except at the end of test, add oil to the crankcase from the leveling sample of 472 mL to bring the oil level, as nearly as possible, back to that following the initial run. At the end of test, return the entire 472 mL purge sample to the engine. Discard any excess leveling sample. Record the results on Fig. A9.1.

11.9 *Air-to-Fuel Ratio Measurement and Control*—Measure the air-to-fuel ratio using the lambda sensors throughout the test. Control the air-to-fuel ratio using the lambda sensor output as feedback for the Powertrain Control Module. See Annex A6.

11.10 *Air-to-Fuel Ratio Verification*—Verify the air-to-fuel ratio measurements made by the lambda sensors using exhaust gas analysis according to the following:

11.10.1 By means of exhaust gas analysis, measure the volume percent of CO₂, CO, and O₂ using an electronic gas analyzer.

11.10.2 Enter either Fig. A6.1 or Table A6.1, constructed for the Sequence IIIG fuel, with the CO₂, CO, and O₂ values to determine the air-to-fuel ratio.

11.10.3 For air-to-fuel ratios greater than 15:1 (lean), when the analysis shows a CO concentration in the exhaust gas, correct the analysis as follows:

11.10.3.1 Determine the corrected O₂ using this relationship:

$$\text{Corrected O}_2 = \text{Observed \% O}_2 - 0.5 (\text{observed \% CO}) \quad (2)$$

11.10.3.2 Determine the corrected CO₂ using this relationship:

$$\text{Corrected CO}_2 = \text{Observed \% CO}_2 + \text{observed \% CO} \quad (3)$$

11.10.3.3 In either Fig. A6.1 or Table A6.1, enter the corrected O₂ and CO₂ values to determine the air-to-fuel ratios for the two gases, which shall agree within 0.5 air-to-fuel ratio.

11.10.4 Measure the air-to-fuel ratio using exhaust gas analysis during the first hour of the test to ensure that the lambda sensors are functioning properly.

11.10.5 Measure the air-to-fuel ratio using exhaust gas analysis during test hours 19, 49, and 99 of the test to ensure that the lambda sensors are functioning properly.

11.11 *Blowby Flow Rate Measurement*—Measure the engine blowby flow rate according to the following instructions, and within 15 min of the end of test, at hours: 1, 6, 11, 16, 21, 26, 31, 36, 41, 46, 51, 56, 61, 66, 71, 76, 81, 86, 91, 96 and 99.

11.11.1 Observe the following requirements:

11.11.2 Measure the blowby flow rate at the condenser outlet.

11.11.3 Seal the dipstick hole during engine operation by using the dipstick-hole plug.

11.11.4 Orient the blowby meter horizontally during measurements.

11.11.5 Direct the blowby gas into a suitable vent hood at all times, other than when the blowby flow rate is being measured. Do not allow the vent system to create a draw on the crankcase.

11.11.6 Connect a surge tank, drawing RX-117431C, to the condenser.

11.11.7 Connect the blowby flow-rate meter to the surge tank.

11.11.8 When permanently installed blowby meters are not used, portable cart applications are allowed. However, position the cart near the testing area for a sufficient time-period to assure temperature stabilization of the system components prior to taking any blowby measurements.

NOTE 10—Temperature stabilization is necessary to reduce condensation precipitation of the blowby gases. The moisture content of blowby gases is generally between (17 and 20) g/g. Correction factors are based on this and other average gas-analysis data of the blowby gases. Therefore, it is important that the blowby gases being measured at the orifice plate be as close in molecular composition and temperature as possible to the blowby gases exiting the condenser.

11.11.9 Do not evacuate or direct the exhaust line for the engine blowby gas being measured toward any low pressure evacuation systems.

11.11.10 Select an orifice size such that the observed blowby flow, ΔP , lies in the midrange of the calibration curve. Record the orifice size used.

11.11.11 Control the crankcase pressure at (0 ± 12.4) Pa.

11.11.12 Maintain blowby gas flow through the orifice meter for 2 min. or more to ensure flow stability, prior to taking the actual readings. Due to the relatively low flow rates, allow time for the engine blowby gas to fill the system and further enhance temperature stabilization.

11.11.13 Record the uncorrected blowby flow rate in litres per minute and correct it for an atmospheric pressure of 100 kPa and a temperature of 37.8 °C, using the correction factors given in [Table A10.1](#).

11.11.14 Alternatively, use the following equation, on which [Table A7.1](#) is based, to correct the blowby flow rate:

$$CF_{si} = \left(3.1002 \left(\frac{Pkpa}{273.15 + t^{\circ}C} \right) \right)^{0.5} \quad (4)$$

where:

CF_{si} = corrected blowby flow rate, L/min,

$Pkpa$ = blowby pressure, kPa, and

$t^{\circ}C$ = temperature, °C.

11.11.15 Disconnect the surge tank from the condenser.

11.12 *NO_x Determinations*—Measure NO_x concentrations using suitable exhaust gas, analysis equipment at 19 h, 49 h, and 99 h, and record the data in the report form set.

11.13 *Data Recording*—Record data for all parameters listed in [Fig. A7.1](#) at a minimum of every 2 min .

11.14 *Initial Run (10 min)*—After charging with the test oil and priming the engine, conduct the 10 min initial run.

11.14.1 Start the engine (see [11.4](#)). Begin timing the 10 min initial run.

11.14.2 Maintain the ignition voltage between (13 to 15) V.

11.14.3 Make certain that coolant is flowing through the water-cooled exhaust manifolds.

11.14.4 Control the coolant jacket at (50.0 ± 2.0) °C, and the condenser coolant temperature at (40.0 ± 2.0) °C during the initial run. Run the temperature control valve for the oil cooler wide open to obtain maximum cooling during the initial run.

11.14.5 Operate the engine at 1500 r/min, 6.34 kW for 10 min; check for leaks.

11.14.6 Ten minutes after the start of the initial run, and just prior to stopping the engine, remove a purge sample of 472 mL, then take the initial oil sample of 236 mL.

11.14.7 Stop the engine (see [11.5](#)).

11.14.8 Follow [11.7](#) and [11.8](#) to determine the oil level after drain-down, in mm; record the value on [Fig. A9.1](#). Use this level as the full mark for the test.

11.15 *Engine Oil Quality Testing (100 h)*—After completing all phases of the initial run, conduct the engine oil quality evaluation portion of the test for 100 h, according to the following procedure:

11.15.1 Start the engine (see [11.4](#)).

11.15.2 Ensure the throttle body humidified air inlet supply to the engine is connected.

11.15.3 Maintain the ignition voltage between (13 to 15) V.

11.15.4 Operate the engine under the test conditions listed in [Annex A7](#).

11.15.5 For each 20 h segment of the engine oil quality testing period of 100 h, test time is counted from the moment when all the test conditions listed in [Annex A7](#) are reached and stabilized. Start calculating QI values when temperatures are stable or when test state warm up times are exceeded. See [Annex A7](#). If engine is shut down for any reason except oil leveling, start counting down time. Maximum allowable down time for the IIIG test is 24 h.

11.15.6 Every 20 h, conduct the oil sampling and oil leveling according to [11.5](#) and [11.6](#). See [Fig. A9.1](#). Record the time when the final leveling is completed at 100 h; be aware that most of the engine disassembly shall be completed within 12 h of this time. See [12.2.1](#).

11.16 *Test Termination*—Terminate the test as follows:

11.16.1 Terminate the test at the completion of the engine oil quality testing period of 100 h, following the taking of the purge and analysis samples and completion of the end of test oil leveling procedure. Record the end-of-test time after the final, engine oil level procedure.

11.16.1.1 Drain the oil sump.

11.16.1.2 Drain the condenser cooling system.

11.16.1.3 Drain the engine coolant.

11.16.1.4 Remove the engine from the test stand, and transport it to the engine disassembly area for determination of test results.

12. Determination of Test Results

12.1 This section describes techniques used to evaluate oil performance with respect to oxidation (viscosity increase), wear (camshaft and lifter), piston deposits, ring sticking, and oil consumption.

12.2 *Engine Disassembly*—Disassemble the engine according to the following instructions, in preparation for inspection, rating, and measurement:

12.2.1 Plan the disassembly so that the parts to be rated for sticking, deposits, and plugging (pistons and rings) are removed from the engine within 12 h of the completion of the oil level.

12.2.2 Remove the components from the top of the engine in order to gain access to the cylinder bores.

12.2.3 Remove the carbon deposits from the top portion of the cylinder walls, above the top compression ring travel, before removing the pistons from the engine.

12.2.4 Disassemble the remainder of the engine.

12.3 *Preparation of Parts for Rating of Sticking, Deposits, and Plugging*—Prepare the specified parts for rating according to the following instructions:

12.3.1 Check all piston rings for freedom of movement in the grooves when removing the pistons from the engine. See [12.4.1](#) through [12.4.1.1](#).

12.3.1.1 Determine which rings are hot-stuck or cold-stuck (see [3.1.12](#) and [3.1.5](#), respectively, for definitions of hot-stuck and cold-stuck rings) and record the piston number and ring identification (for example, piston No. 3, top ring) for such rings on Form 8, Summary of Oil Ring Land Deposit Rating, in standardized report form set (see [Annex A5](#)). Record the total number of hot-stuck rings on Form 4, Test Result Summary, in the standardized report form set (see [Annex A5](#)).

12.3.2 At time of disassembly, remove all piston rings that are free. Leave any stuck rings (includes pinched rings; see 3.2.9) in place. Apply a rating of 100 % heavy carbon in the groove to any piston groove that cannot be rated, due to the presence of a stuck ring.

12.3.3 If the piston deposits cannot be rated immediately after the pistons are removed from the engine, store the pistons in a desiccator for no longer than 72 h from end of test before rating. Do not wipe the pistons before storing them, see 12.4.

12.4 *Piston Deposit Ratings*—Rate the pistons for piston skirt varnish as well as deposits on the ring lands, under-crown area, and in the ring grooves.

12.4.1 Gently wipe off excess oil from the piston skirts with a soft cloth.

12.4.1.1 Do not apply any chemicals or build-up oil to the pistons prior to rating them for deposits.

12.4.2 Rate each piston top groove, 2nd groove, oil ring groove, 2nd land, and undercrown area (where the horizontal and vertical planes meet) for deposits using CRC Manual No. 20²⁷ rating techniques and breakdown methods. Carbon deposit ratings will consist of only two levels: Heavy (0.00 merit value) or Light (0.75 merit value). Perform these ratings in a rating booth, using a 20-segment piston-rating cap, a piston rating stand, and a 22 W circular rating lamp.

12.4.2.1 The undercrown area to be rated is defined as the area on the undercrown of the piston that demarcated by casting lines on the piston itself, which resembles a common adhesive bandage. Rate only the area on the underside of the piston crown. Do not rate any parts on the inside surface of the piston skirts as part of the undercrown rating.

12.4.2.2 Report any unusual deposits observed in the comments Section of Summary of Piston Deposits in standardized report form set (see Annex A5).

12.4.3 If multiple ratings are deemed necessary of a given part or parts, consensus rating may be used according to the following:

12.4.3.1 The raters shall be from the laboratory in question, no outside raters may be used unless requested and directed through the Sequence IIIG Surveillance Panel.

12.4.3.2 No averaging of ratings is permitted.

12.4.3.3 Report only one rating value, which is agreed to by the involved raters.

12.4.3.4 All raters of Sequence IIIG engine pistons shall attend an SAE Light Duty Deposit Rating Workshop every 12 months \pm 30 days and produce data that meet the SAE definition of Blue, Red, or White for piston deposits. If a rater is unable to meet this requirement, the rater can continue to rate Sequence IIIG pistons after the completion of the workshop for a grace period of 45 days and can follow the procedure described in 12.4.3.5 to generate data that meet the SAE definitions of Blue, Red, or White.

12.4.3.5 A rater who is unable to meet the requirement in 12.4.3.4 can schedule a visit to the TMC to generate data on SAE Light Duty Deposit Rating Workshop pistons and receive

an assessment of rating performance compared to data collected at recent workshops. Visits to the TMC will be scheduled based on availability of parts.

12.4.3.6 The TMC will select a minimum of six pistons from a collection of workshop parts for the rater to rate piston deposits. The TMC will provide rating booths and lights, but the rater is responsible for providing any necessary rating aids. The TMC will analyze the data and determine if the requirement in 12.4.3.4 has been met. If the requirement in 12.4.3.4 has not been met, any time remaining in the 45 day grace period is forfeited.

12.4.3.7 A second attempt to generate rating data at the TMC is permitted only after the rater receives training from an experienced industry rater. The experienced industry rater shall verify to the TMC, in writing, that the rater training has taken place. No more than two attempts are permitted between SAE Light Duty Deposit Rating Workshops.

12.4.4 Average each individual piston (thrust side and anti-thrust side) for inclusion in the Weighted Piston Deposit (WPD) results.

12.4.5 Calculate the average of the six oil ring land (land 3) ratings and record this as the average oil ring land deposits on Form 8, Summary of Oil Ring Land Deposit Rating (ORLD), and on Form 4, Test Results Summary, in standardized report form set (see Annex A5).

12.4.6 *Weighted Piston Deposit Rating (WPD)*—This weighted piston rating is comprised of skirt varnish, top groove, 2nd groove, oil ring groove, under-crown, 2nd land, and 3rd land.

12.4.6.1 Calculate the Weighted Piston Deposit (WPD) result for each individual piston is calculated using the following weighting factors:

Piston Under-crown	10 %
2nd Land	15 %
3rd Land (ORLD)	30 %
Piston Skirts (APV)	10 %
Top Groove	5 %
2nd Groove	10 %
Oil Ring Groove	20 %

12.4.6.2 Calculate the Weighted Piston Deposit result for each piston by multiplying the rated result for each piston part by the weighting factor in 12.4.6.1 (in decimal form) to determine a weighted rating for that piston part. The Weighted Piston Deposit result is the sum of the weighted ratings for the individual piston parts.

12.4.6.3 The Weighted Piston Deposit (WPD) result for the test is calculated by a simple average of the six individual piston WPD ratings.

12.5 *Post-Test Camshaft and Lifter Wear Measurements*—Measure the wear of the camshaft lobes and lifters to the nearest 0.001 mm. Refer to Practice E29 for any needed rounding; use the rounding-off method. Proceed according to the following procedure:

12.5.1 Clean the camshaft lobes and lifters with degreasing solvent; blow-dry them with clean, dry shop air.

12.5.2 Store the camshaft and lifters in a temperature-controlled room, before making dimensional measurements, for at least 90 min to ensure temperature stabilization. The temperature of the post-test measurement room shall be within 3 °C of the temperature of the pre-test measurement room.

²⁷ CRC Manual 20, “Rating Techniques and Breakdown Methods,” available from Coordinating Research Council, Inc., 219 Perimeter Center Parkway, Atlanta, GA 30346.

12.5.3 Make the camshaft measurement using Mitutoyo Snap Gauge, model 201-152, and a Mitutoyo Digital Indicator, model 543-252B, to measure the camshaft lobes. Make the lifter measurement with a digital indicator equipped with a Mitutoyo 4.3 mm flat tip, model 131-259 mounted in a indicator stand. Equip the indicator stand with a V-block that is rigidly mounted to the base and locates the lifter with its center axis in line with the digital indicator.

12.5.3.1 Use dimensional measuring equipment accurate to 0.01 mm. Before each measurement session, use standards traceable to the National Institute of Standards and Technology (NIST), to ensure measuring equipment accuracy. Include standards having length values within 1.3 mm of the typical lifter and lobe measurements taken. Use the same equipment and standards for post-test measuring as were used for pre-test measuring. If a calibration shift between pre-test and post-test measurements is detected, evaluate the shift to determine its effect on the wear measurements. Record the results of the evaluation, and any corrective action taken.

12.5.4 The same person shall measure the camshaft and the lifters used in a given test if the measurement equipment utilized is operator-sensitive (that is, if the micrometer has operator-determined spindle pressure).

12.5.5 When measuring the camshaft and the lifters, take precautions to prevent any influence of body heat on the measurements.

12.5.6 Measure the maximum dimension of each camshaft lobe, transverse to the camshaft axis. This dimension is at the rear edge of all lobes (lobes are numbered from the front to the rear of the camshaft).

12.5.7 Measure the length of the lifters at the center of the lifter foot.

12.5.8 Calculate the wear for each camshaft lobe and lifter by subtracting the after-test measurement from the before-test measurement.

12.5.8.1 Due to varnish accumulations on camshaft lobes of high wear resistant oils, post-test measurements may indicate a larger numeric value than pre-test measurements. In this situation, the end of test calculation equates to a negative value. All negative values shall be overridden and entered as 0.000 mm wear for all calculations when determining post-test results.

12.5.9 Calculate the cam-plus-lifter wear by adding the values obtained in 12.5.8. Record the results on Form 7, Valve Lifter and Camshaft Wear Results, in standardized report form set (see Annex A5).

12.5.10 Determine the maximum, minimum, and average camshaft-lobe, valve-lifter, and cam-plus-lifter wear. Record the values on Form 7, Valve Lifter and Camshaft Wear Results, in standardized report form set (see Annex A5).

12.6 *Viscosity Test*—Determine the viscosity of a sample of the fresh test oil and of the nine test samples by analysis according to the following instructions:

12.6.1 Do not filter the samples.

12.6.2 Use Test Method D445.

12.6.3 Use either the Cannon-Fenske Routine Viscometer of the Ostwald Type for Transparent Liquids or the Cannon-

Fenske Opaque Viscometer of the Reverse-Flow Type for Transparent and Opaque Liquids.

12.6.4 Conduct the measurement at 40 °C.

12.6.5 Record the results (see Annex A5).

12.6.6 Critically examine the relationship of the viscosity of the initial oil sample to that of the new oil. The viscosity of the initial sample can legitimately be as much as 10 mm²/s less than that of the new oil, because of permanent shearing effects. If the difference is greater than 10 mm²/s, explore possible causes such as failure to purge the oil sample line [removing the 473 mL purge sample] prior to withdrawing the 237 mL analysis sample, or an excessive amount of build-up oil in the system.

12.6.7 Calculate the change in viscosity in mm²/s, from the value for the initial sample, for the last five samples. Record the changes on Form 6, Used Oil Analysis Results, in standardized report form set (see Annex A5). Record the final percent viscosity increase on Form 4, Test Result Summary, in standardized report form set (see Annex A5).

12.6.8 Calculation instructions for special cases related to percent viscosity increase:

12.6.8.1 Instructions for calculating and reporting results if the Final Original Units Result on Form 4 (see Annex A5) for percent viscosity increase is zero or negative.

(1) The minimum result that will be considered for the percent viscosity increase is 0.1 %. Substitute 0.1 for the original unit result and complete the calculations on Form 4 (see Annex A5). A notation is required in the Other Comments & Outliers Section of Form 13 (see Annex A5) indicating that the Original Units Result has been modified for a special case.

12.6.8.2 Instructions for calculating and reporting results of the Viscosity Result on Form 6 (see Annex A5) for Viscosity Increase Data is Too Viscous to Measure (TVTM).

(1) The maximum kinematic viscosity result reported will be 8000 mm²/s using either equipment noted in 12.6.3, use a tube size of 500 or less. If the measured viscosity is 8000 mm²/s using tube size 500, this will be considered the maximum reportable viscosity. Report 8000 mm²/s on Form 6 (see Annex A5) for entry in the column listed as Viscosity and use this value for the calculating Change and Percent. (This will provide consistent TVTM data for reporting purposes and it also expands the maximum viscosity to fill the space allowed by the Data Dictionary.)

(2) Complete the calculations on Form 4 (see Annex A5) for percent viscosity increase using the percent value for the final drain from Form 6 except that the Severity Adjustment (SA) displayed and used for percent viscosity increase calculations will be set to zero (0). A notation is required in the Other Comments & Outliers Section of Form 13 (see Annex A5) indicating that the Severity Adjustment has been modified for a special case.

12.7 *Testing Oil Samples for Wear Metals*—Use Test Method D5185 to perform Inductively Coupled Plasma Optical Emission Spectrometry (ICP) Analysis on the initial and all 20 h oil samples for iron, copper, and lead concentrations in the oil. Report the results of the ICP Analysis on these three metals on Form 6 (see Annex A5).

12.8 *Blowby Flow Rate Measurements*—Plot blowby flow rate measurements on Form 10, Blowby Results & Plot, in standardized report form set (see [Annex A5](#)).

12.9 *Oil Consumption Computation*—Compute the oil consumption for the test as follows:

12.9.1 See [Fig. A9.1](#) for the oil-consumption calculation equation.

12.9.2 Determine the total fresh oil added to the engine during the initial oil leveling run and 20 h test periods in of [Fig. A9.1](#). Enter the total in the End-Of-Test Total column on [Fig. A9.1](#) in position *a*.

12.9.3 Determine the total amount of oil discarded during the 100 h test periods in of [Fig. A9.1](#). Enter the total in the end-of-test total column on [Fig. A9.1](#) in position *b*.

12.9.4 Determine the oil level in millilitres at the end of the test, in [Fig. A9.1](#). Enter the number in the end-of-test total column on [Fig. A9.1](#) in position *c*.

12.9.5 Add the values determined in [12.9.2](#) and [12.9.4](#), and subtract the value determined in [12.9.3](#). Subtract 236 mL (the final oil sample, which is not replaced with new oil) from the value computed above and enter the remainder, which is the amount of oil consumed in the test, in the blank for total oil consumption in the [Fig. A9.1](#).

12.9.6 To determine the computed millilitres low value for the 100 h oil level only, subtract 708 mL from the value determined in [12.9.4](#). This is done to account for samples not returned (236 mL analysis sample and 472 mL of new oil) to the engine as in previous oil levels. This value is entered on Form 5 of the test report (see [Annex A5](#)).

12.9.7 For non-reference oils, the test results are considered non-interpretable for the purpose of Multiple Test Acceptance Criteria (MTAC) if the oil consumption at the end of test exceeds 4.65 L.

12.10 *Photographs of Test Parts*—Take color photographs of the test parts for inclusion in the test report, as follows:

12.10.1 Photograph pistons after completing all ratings.

12.10.2 Do not coat the pistons with build-up oil (for preservation) before the photographs are taken. Do not re-install piston rings.

12.10.3 Photograph all six piston thrust sides in one shot. Piston labels are not required (see [12.10.7](#)).

12.10.4 Photograph all six piston anti-thrust sides in one shot. Piston labels are not required (see [12.10.7](#)).

12.10.5 Size the final piston photographs for inclusion in the test report so that the overall piston height is not less than 5 cm, but small enough that three photographs can be mounted in a column on the 28 cm dimension of a (22 by 28) cm sheet of paper.

12.10.6 Assemble the photographs on two pages, with the thrust side photographs on one page, and the anti-thrust photographs on the other page.

12.10.7 Mount the photographs on each of the two pages with the reciprocating axes of the pistons parallel to the 28 cm dimension of the page. Arrange the photographs in two vertical columns of three each, with the No. 1 piston in the upper left corner of the page, No. 2 piston in the upper right corner, No. 3 piston in the center of the left column, and so forth.

12.11 *Retention of Representative Test Parts*—Retain for at least 6 months all camshafts and lifters.

12.12 *Severity Adjustments*—Calculate severity adjustments (SA) for results of non-reference engine oil tests. Use the control chart technique (see [12.13.1](#)) for determining the laboratory bias for percent viscosity increase, piston skirt varnish, and weighted piston deposits. Enter the adjustments on Form 4, Test Result Summary, in standardized report form set (see [Annex A5](#)).

12.12.1 Download the document, “The Lubricant Test Monitoring System,” from internet website (<ftp://ftp.astmtmc.cmu.edu/docs/ltms/ltms.pdf>) for information on the Sequence IIIG Test Control Chart Technique For Developing And Applying Severity Adjustments (SA)^{11,18}; a printed copy can be obtained from the TMC.²

12.13 *Determination of Operational Validity*—Determine and document the operational validity of every Sequence IIIG test conducted, according to the following:

12.13.1 Complete the report forms to substantiate that the test stand, engine build-up, installation of the engine on the test stand, and the test operation conformed to the procedures specified in this test method.

12.13.2 Inspect the test records for instances of downtime (excluding the initial oil level run of the test), and record any such instances on Form 13, Downtime and Outlier Report Form, in standardized report form set (see [Annex A5](#)). When performing each 20 h oil level adjustment, identify as downtime any time in excess of 55 min from the time when the engine ramps down until the test is back on test operating conditions. Enter the total downtime on Form 13, Downtime and Outlier Report Form, in standardized report form set (see [Annex A5](#)). If the total downtime exceeds 24 h, note on Form 1, in standardized report form set (see [Annex A5](#)) that the test is invalid.

12.13.3 If the end of test quality-index value is below 0.000, conduct an engineering review of the test operations. The test laboratory shall conduct the engineering review of reference oil tests and report their findings to the Test Monitoring Center.²⁵ If needed, additional industry experts may be consulted. Document the results of the engineering review.

13. Report

13.1 *Report Forms*—For reference oil tests, the standardized report form set and data dictionary for reporting test results and for summarizing the operational data are required.

NOTE 11—The non-reference oil test results should also be reported on these same forms if the results are intended to be submitted as candidate oil results against a specification.

13.2 *Precision of Reported Units*—Use Practice [E29](#) for rounding off data; use the rounding-off method. Report the data to the same precision as indicated in [Annex A8](#).

14. Precision and Bias

14.1 *Precision*—Test precision is established based on reference oil test results (for operationally valid tests) monitored by the ASTM Test Monitoring Center.²⁵ [Table 1](#) summarizes reference oil precision of the test based on results obtained with

TABLE 1 Test Precision^A

Test Result	Intermediate Precision ^B		Reproducibility ^C	
	S _{i.p.} ^D	i.p.	S _R ^D	R
Percent Viscosity Increase ^E	0.392	1.098	0.392	1.098
Weighted Piston Deposits Average	0.655	1.834	0.702	1.966
Camshaft & Lifter Wear	0.224	0.627	0.224	0.627

^A Based on results obtained on Test Monitoring Center Reference Oils 434, 435, and 438 over the period from June 3, 2003 to December 22, 2004.

^B See 14.1.1.

^C See 14.1.2.

^D S = standard deviation.

^E This parameter is transformed, using the transformation shown in Footnote B. When comparing two test results on this parameter, first apply the transformation to each test result. Compare the absolute difference between the transformed results with the appropriate (intermediate precision or reproducibility) precision limit.

PVIS = Percent viscosity increase at 100 h, in transformed units. The results transformed using the transformation: $\ln(\text{PVIS})$.

WPD = Weighted Piston Deposits, in merits.

ACLW = Average Camshaft plus Lifter Wear, in transformed units. The results transformed using the transformation: $\ln(\text{ACLW})$.

Test Monitoring Center Reference Oils. Contact the TMC for current precision values.

14.1.1 *Intermediate Precision Conditions*—Conditions where test results are obtained with the same test method using the same oil, with changing conditions such as operators, measuring equipment, test stands and time.

NOTE 12—Intermediate Precision is the appropriate term for this test method, rather than repeatability, which defines more rigorous within-laboratory conditions.

14.1.1.1 *Intermediate Precision Limit (i.p.)*—The difference between two results obtained under intermediate precision conditions that would, in the long run, in the normal and correct conduct of the test method, exceed the values shown in Table 1 in only one case in twenty. When only a single test result is available, the Intermediate Precision Limit can be used to calculate a range (test result \pm Intermediate Precision Limit) outside of which a second test result would be expected to fall about one time in twenty.

14.1.2 *Reproducibility Conditions*—Conditions where test results are obtained with the same test method using the same test oil in different laboratories with different operators using different equipment.

14.1.2.1 *Reproducibility Limit (R)*—The difference between two results obtained under reproducibility conditions that would in the long run, in the normal and correct conduct of the test method, exceed the values shown in Table 1 in only one case in twenty. When only a single test result is available, the Reproducibility Limit can be used to calculate a range (test result \pm Reproducibility Limit) outside of which a second test result would be expected to fall about one time in twenty.

15. Keywords

15.1 cam and lifter wear; deposits; engine oil; engine wear; high-temperature performance; oil consumption; oil thickening; oil viscosity; oxidation resistance; Sequence IIIG test; spark-ignition automotive engine; varnish; varnish deposition

ANNEXES

(Mandatory Information)

A1. THE ROLE OF THE ASTM TEST MONITORING CENTER AND THE CALIBRATION PROGRAM

A1.1 *Nature and Functions of the ASTM Test Monitoring Center (TMC)*—The TMC, located in Pittsburgh, PA, is a non-profit organization directed by Subcommittee D02.B and the Test Monitoring Board. The TMC is staffed to administer engineering studies; conduct laboratory visits; perform statistical analyses of reference oil test data; blend, store, and ship reference oils; and provide the associated administrative functions to maintain the referencing calibration program for various lubricant tests. It coordinates its activities with the test sponsors, the test developers, the surveillance panels, and the testing laboratories.

A1.2 *Rules of Operation of the TMC*—The TMC operates in accordance with the ASTM Charter, the ASTM Bylaws, the Regulations Governing ASTM Technical Committees, the Bylaws Governing ASTM Committee D02, and the Rules and Regulations Governing the ASTM Test Monitoring System.

A1.3 *Management of the TMC*—The management of the Test Monitoring System is vested in the Test Monitoring Board (TMB) elected by Subcommittee D02.B. The TMB selects the TMC Administrator who is responsible for directing the activities of the TMC staff.

A1.4 *Operating Income of the TMC*—The TMC funds its operations with income from fees levied on the reference oils supplied and on the calibration tests conducted. Subcommittee D02.B reviews and establishes the TMC's Fee schedules.

A1.5 *Conducting a Reference Oil Test:*

A1.5.1 For those laboratories which choose to utilize the services of the TMC in maintaining calibration of test stands, full-scale calibration testing shall be conducted at regular intervals. These full-scale tests are conducted using coded reference oils supplied by the TMC. It is a laboratory's responsibility to maintain the calibration in accordance with the test procedure. It is also a laboratory's responsibility to keep the on-site reference oil inventory at or above the minimum level specified by the TMC test engineers.

A1.5.2 When laboratory personnel decide to run a reference calibration test, they shall request an oil code from the cognizant TMC engineer. Upon completion of the reference oil test, the data shall be sent in summary form (use TMC-acceptable forms) to the TMC by telephone facsimile transmission, or by some other method acceptable to the TMC. The TMC will review the data and contact the laboratory engineer

to report the laboratory’s calibration status. All reference oil tests, whether aborted, invalidated, or successfully completed, shall be reported to the TMC. Subsequent to sending the data in summary form to the TMC, the laboratory is required to submit to the TMC the written test report specified in the test procedure.

A1.6 New Laboratories—Laboratories wishing to become a part of the ASTM Test Monitoring System will be requested to conduct reference oil tests to ensure that the laboratory is using the proper testing techniques. Information concerning fees, laboratory inspection, reagents, testing practices, appropriate committee membership, and rater training is available by contacting the TMC Administrator at ASTM Test Monitoring Center, 6555 Penn Ave. Pittsburgh, PA 15206.

A1.7 Introducing New Sequence IIIG Reference Oils—The calibrating reference oils produce various wear, oil thickening, and deposit characteristics. When new reference oils are selected, member laboratories will be requested to conduct their share of tests to enable the TMC to establish the proper industry average and test acceptance limits. The ASTM D02.B0.01 Sequence IIIG Surveillance Panel requires a conducting of a minimum of four tests prior to establishing the industry average and test acceptance targets for new reference oils. The TMC estimates that it will normally request laboratories to run no more than one contributing test per year per test stand.

A1.8 TMC Information Letters:

A1.8.1 Occasionally, it is necessary to change the procedure, and notify the test laboratories of the change, prior to consideration of the change by either ASTM Subcommittee D02.B on Automotive Lubricants or ASTM Committee D02 on Petroleum Products and Lubricants. In such a case, the TMC will issue an Information Letter. Subsequently, prior to each semi-annual Committee D02 meeting, the accumulated Information Letters are balloted by ASTM Subcommittee D02.B. The ballot is reviewed at the ASTM Subcommittee D02.B meeting, and the actions taken are considered at a meeting of ASTM Committee D02. By this means, the Society due process procedures are applied to these Information Letters.

A1.8.2 The review of an Information Letter prior to its original issue will differ according to its nature. In the case of an Information Letter concerning a part number change, which does not affect test results, the TMC is authorized to issue such a letter. Long-term studies by the surveillance panel to improve the test procedure through improved operation and hardware control may result in a recommendation to issue an Information Letter. If obvious procedural items affecting test results need immediate attention, the test sponsor and the TMC will issue an Information Letter and present the background and data to the surveillance panel for approval prior to the semi-annual ASTM Subcommittee D02.B meeting.

A1.8.3 Authority for the issuance of Information Letters was given by the ASTM Committee on Technical Committee Operations (COTCO) in 1984, as follows:

“COTCO recognizes that D-2 has a unique and complex situation. The use of Information Letters is approved providing each letter contains a disclaimer to the effect that such has not obtained ASTM consensus. These Information Letters should be moved to such consensus as rapidly as possible.”

A1.8.4 Information Letters appertaining to this procedure issued prior to 2002-03-15 are incorporated in this test method. A listing of such Information Letters, and copies of the letters, may be obtained from the TMC. Information Letters issued subsequent to this date may also be obtained from the TMC.

A1.9 TMC Memoranda—In addition to the aforementioned Information Letters, the TMC issues supplementary memoranda. The TMC develops and distributes these to the Sequence IIIG Test Surveillance Panel and to participating laboratories. These memoranda convey such information as batch approvals for test parts or materials, clarification of the test procedure, notes and suggestions for the collection and analysis of special data that the TMC may request, or for any other pertinent matters having no direct effect on the test performance, results, or precision and bias.

A1.10 Precision Data—The TMC determines the current Sequence IIIG test precision by analyzing results of calibration tests conducted on reference oils. For current precision data, contact TMC.²

A2. SEQUENCE IIIG TEST PARTS REPLACEMENT GUIDELINES

A2.1 [Table A2.1](#) and [Table A2.2](#) list the parts to replaced every test and as necessary, respectively. Also for every test, replace all parts not listed in [Table A2.1](#) and [Table A2.2](#).

TABLE A2.1 Parts to be Replaced Every Test

Part Description	Part Number
Arm, Rocker with Pivot Bearing	OHT3F-058-1
BEARING, KIT, ENGINE	OHT3F-042-2
KIT INCLUDES:	
BEARING, CONNECTING ROD, KIT, UPPER AND LOWER, OH-106 ASSY	3F042-01
MAIN BEARING KIT, OH101 ASSY, INCLUDES:	3F042-02
Bearing, Balance Shaft Front (part of 24502388)	SKF6205-2ZNRJEM

TABLE A2.1 *Continued*

Part Description	Part Number
BEARING, MAIN, LOWER, #1 AND 3	OH-102
BEARING, MAIN, LOWER, #4	OH-103
BEARING, MAIN, LOWER, FLANGE, #2	OH-104
BEARING, MAIN, UPPER, FLANGE, #2	OH-105
BEARING, CAM BUSHING, POSITIONS 1 & 4	3F028-09
BEARING, CAM BUSHING, POSITIONS 2 & 3	3F028-10
Bolt, Camshaft Sp rocket	24501366
Bolt, Cylinder Head, Long	25527831
Bolt, Cylinder Head, Short	25533811 or 88891770
Bolt, Flywheel	24505092
Bolt, Main Cap	24503056
Bolt, Main Cap, Side	24505576
Bolt, Rear Cover Housing	24503970
Bolt, Rocker Arm, Special Test	3F-058-02
Bolt/Screw, Thrust Plate retainer	25519242
Camshaft, Special Test, including Manganese-phosphate coating	OHT3F-008-8
Cap, Valve Spring Retainer	24502257
Chain, Timing	24504668
Clip, Retainer, Piston Pin	OHT3F-012-1
COOLER, OIL, NICKEL PLATED, BYPASS CLOSED	OHT3F-030-2
Damper, Timing Chain (includes bolt, retaining ring)	24503893
FILTER, PRO TEC	OHT3F-057-3
Gasket kit, Intake Manifold lower	89017399 or 89017816
Gasket, Cylinder Head, left	24503802
Gasket, Cylinder Head, right	24503801
Gasket, Front Cover	12587003
Gasket, Oil Filter Adapter	25534742
Gasket, Oil Pan	OHT3G-093-1
Gasket, Oil Suction Tube	24501259
Gasket, Rear Cover Housing	24507388
Gasket, Rocker Cover	25532619
Gasket, Water Outlet	24502433
Gasket, Water Pump	24501565
Head, Cylinder	24502260
Key, Camshaft Sprocket	24500618
Key, Valve Stem Keeper	1016634
Lifter, Test ACI w/Flat (25338738A)	OHT3F-029-3
PIN, PISTON WRIST, PKG. OF 6	OHT3F-014-1
PISTON, TEST, RUNS 1 & 2, GRADE 12	OHT3F-053-1
PISTON, TEST, RUNS 3 & 4, GRADE 34	OHT3F-054-1
PISTON, TEST, RUNS 5 & 6, GRADE 56	OHT3F-055-1
PLATE, CAMSHAFT THRUST, .1520 in. THICKNESS	OHT3F-011-2
Plug, Engine Block Core Hole	24500867
Plug, Cylinder Head Core Hole	3835577
Plug, Cylinder Head Cup	24502262
Plug, Engine Block, Oil Gallery	3835577
Plug, Ignition Spark	NGK TR-6
Plunger, Oil Relief	25530949
PUSHROD, SPECIAL LENGTH, PKG. OF 12	OHT3F-007-1
RETAINER CLIP, PISTON PIN PKG. OF 12	OHT3F-012-1
1 EA. RING, PISTON, RUN 1, ENGINE SET	OHT3F-050-RUN1
1 EA. RING, PISTON, RUN 2, ENGINE SET	OHT3F-050-RUN2
1 EA. RING, PISTON, RUN 3, ENGINE SET	OHT3F-051-RUN3
1 EA. RING, PISTON, RUN 4, ENGINE SET	OHT3F-051-RUN4
1 EA. RING, PISTON, RUN 5, ENGINE SET	OHT3F-052-RUN5
1 EA. RING, PISTON, RUN 6, ENGINE SET	OHT3F 052 RUN6
ROCKER ARM ASSEMBLY (Includes: 3F058-02)	OHT3F-058-1
Rod, Connecting (powdered metal)	12593374
Seal, Crankshaft Front Oil (24504098)	OHT3G-092-1
Seal, Crankshaft Rear Oil (25534760)	OHT3G-091-1
SEAL, EXHAUST VALVE STEM	OHT3F-061-1
SEAL, INTAKE VALVE STEM	OHT3F-060-1
Spring, Oil Relief Valve	1262505
SPRING, VALVE Special Test (COLOR CODE YELLOW)	OHT3F-059-5
Sprocket, Camshaft	24505306
Valve, Exhaust (STD)	12579949
Valve, Intake (STD)	12569550

TABLE A2.2 **Parts to be Replaced As Needed**

Part Description	Part Number
ADAPTER, BLOWBY BREATHER TUBE	OHT3F-040-1
ADAPTER, OIL FILTER	OHT3F-035-1

TABLE A2.2 *Continued*

Part Description	Part Number
Adapter, Oil Filter, with External Bypass	OHT3F-080-1
Adapter, Throttle Body, Air Inlet	OHT3F-001-2
Balancer, Harmonic (24507058 or 12563265) (1997–2003)	24507058
Bearing, Balance Shaft Front (part of 24502388)	SKF6205-2ZNRJEM
Block, Engine Assembly	24506028
Bolt, Connecting Rod	12568069
Bolt, Counter Balance Gear	24501367
Bolt, Counter Balance Shaft retainer	24500055
Bolt, Harmonic Balancer	24504736
Bolt, Oil Filter Adapter	24504713
Bolt, Oil Pan (24502791 or 24508626) (1997–2003)	24508626
Bolt, Oil Suction Tube	24505570
Bolt, Rocker Cover W / Washer (25534748 or 24502164) (1997–2003)	24502164
Bolt, Screw Camshaft Sensor	25526395
Bolt, Screw, Oil Gearotor, Cover	25519242
Bolt, Stud Type, Front Cover & Crankshaft Sensor (long)	24504718
Bolt, Stud Type, Front Cover & Crankshaft Sensor (short)	24504717
Bolt, Upper Intake Long	24505205
Bolt, Upper Intake Short	24506498
Bolt, Upper Intake, Stud	24502453
BRACKET, BREATHER TUBE	OHT3F-041-1
BREATHER TUBE, S.S. MATERIAL	OHT3F-075-1
Bushing, Balance Shaft Rear	24503193
BUSHING, ROCKER COVER	OHT3F-028-1
BUSHING, ROCKER COVER	OHT3F-028-2
CONNECTOR, MODIFIED FOR LENGTH, GM PN 24502883	OHT3F-039-2
COVER, FRONT, IMPREGNATED	OHT3G-085-1
COVER, Rear, crankshaft rear seal housing	OHT3G-088-1
Cover, Oil Gearotor	25521935
Cover, Rocker Arm Valve Cover Left Side Plastic	12590366
Crankshaft	34502168
DIP STICK, METRIC, EXTENDED LENGTH	OHT3G-064-1
FITTING, OIL FILTER ADAPTER	OHT3F-043-1
FLYWHEEL, MANUAL, MODIFIED P.N. 24503285	OHT3F-020-2
GASKET, EXHAUST, END PLATE	OHT3F-009-1
GASKET, EXHAUST, FLANGE, METAL	OHT3F-018-1
Gasket, Manifold, Upper Intake	89017556
GASKET, OIL COOLER, PKG. OF 50	OHT3F-074-1
GASKET, OIL FILTER, PKG. OF 50	OHT3F-062-1
Gear, Balanceshaft Drive	24504792
Gear, Balanceshaft Driven	24503524
Gear, Counter Balance Drive	24504792
Gear, Counter Balance Shaft	24503524
Grommet, Rocker Arm Valve cover bolt	25534749
HARNESSES, COIL PACK SEGMENT	3F022-2
HARNESSES, FUEL INJECTOR SEGMENT	3F022-1
HARNESSES, WIRING, DYNO W/ OHT3F-056-1 SENSOR	OHT3F-022-1
HOUSING, ASSEMBLY, BYPASS VALVE	OHT3F-084-1
Injector, Fuel	17120601
Key, Crankshaft	25534912 or 12563282
Magnet, Camshaft Position Sensor	10456195
MANIFOLD, CAST IRON	OHT3F-003-0
MANIFOLD, EXHAUST, WATER COOLED ASSY (ONE BANK)	OHT3F-003-1
ASSEMBLY INCLUDES:	
1 EA. RUNNER, EXHAUST MANIFOLD	OHT3F-004-1
1 EA. PLATE, REAR, EXHAUST MANIFOLD	OHT3F-005-1
1 EA. ELBOW, EXHAUST, MODIFIED	OHT3F-005A-1
1 EA. PLATE, FRONT, EXHAUST MANIFOLD	OHT3F-006-1
2 EA. GASKET, EXHAUST, END PLATE	OHT3F-009-1
1 EA. GASKET, EXHAUST, FLANGE, METAL	OHT3F-018-1
Manifold, Lower Intake	24505728
Manifold, Upper Intake	17096162
METER, BLOWBY	RX-116169-A1 REV N
Module, Assembly, Coil Pack	1103948
MOUNT FRONT ENGINE W/ BOLT PATTERN FOR COIL PACK	OHT3F-026-1
MOUNT, REAR ENGINE HOUSING W/AIR STARTER, MUFFLER & SHIM PACK	OHT3F-025-1
ASSEMBLY INCLUDES:	
STARTER, AIR	3F025-03
MUFFLER, STARTER, AIR	3F025-04
SHIM PACK, STARTER, AIR	3F025-05
MUFFLER, STARTER, AIR	3F025-04
Nut, Throttle Body Fuel Rail Retainer	24506469
Nut, Throttle body Retainer	24506469
OIL FILTER HOUSING ASSEMBLY, NO BYPASS, IMPREGNATED	OHT3G-080-1

TABLE A2.2 *Continued*

Part Description	Part Number
OUTLET, COOLANT	OHT3F-034-1
PAN, IIIF TEST, NICKEL PLATED	OHT3F-073-1
PCM, SPECIAL	OHT3F-021-1
PCV, DUMMY	OHT3F-002-1
Pin, Cylinder Head Locating	25536320
Pin, Front Cover Lower	25536323
Pin, Front Cover Upper	24501162
Pin, Transmission Locating	12338076
PLATE, EGR BLOCKOFF	OHT3F-024-1
PLATE, FRONT, EXHAUST MANIFOLD	OHT3F-006-1
PLATE, REAR, EXHAUST MANIFOLD	OHT3F-005-1
PLATE, WATER PUMP HOUSING	OHT3F-031-1
Plug, Auto Hex, Socket, (Main Oil Gallery Block Off)	444777
PLUG, DIP STICK	OHT3F-065-1
PLUG, DRAIN, MODIFIED	OHT3F-063-1
Pump, Oil, Gearoter Set	24505433
Rail, Fuel	17098211
Rail, Fuel Injector	17120601
REAMER, DIP STICK AND DIP STICK HOLE PLUG	OHT3F-071-1
Regulator, Fuel Pressure, on Rail	17113346
Retainer, Counter Balance, Timing Chain Oiler	24500374
Retainer, Rocker arm (replace after 6 tests)	24502278
RUNNER, EXHAUST MANIFOLD	OHT3F-004-1
Screen, Oil pump (w/suction pipe)	24505569
Seal, oil pan drain plug (o ring)	3536966
Sensor, Camshaft Position	10456148
Sensor, MAF	24503983
Sensor, Mass Air Flow (2 Bolt, Use with Throttle Body 24507235)	24503983
Sensor, Mass Air Flow (3 Bolt, Use with Throttle Body 24507230)	24504302
SENSOR, MODIFIED COOLANT TEMPERATURE	OHT3F-056-1
Shaft Assembly, Counter Balance	24502388 or 24506557
Shield, Crankshaft Position Sensor	24506440
SHIM PACK, STARTER, AIR	3F025-05
SHIM, STEEL, 0.127 mm THICK, 10 PER PKG.	OHT3F-072-005
SHIM, STEEL, 0.254 mm THICK, 10 PER PKG.	OHT3F-072-010
SHIM, STEEL, 0.381 mm THICK, 10 PER PKG.	OHT3F-072-015
SHIM, STEEL, 0.508 mm THICK, 10 PER PKG.	OHT3F-072-020
SHIM, STEEL, 0.787 mm THICK, 10 PER PKG.	OHT3F-072-031
SLEEVE, VALVE STEM PROTECTORS (PKG. OF 100)	OHT3F-070-1
SPROCKET, CRANKSHAFT, SPECIAL 2 PC	OHT3F-036-1
STARTER, AIR	3F025-03
Stud, front cover (2)	24504717
Stud, front cover (2)	24504718
Support, throttle body	24504697
Throttle Body (2 Bolt Mass Air Flow Sensor)	24507235
Throttle Body (3 Bolt Mass Air Flow Sensor)	24504302
TOOL, CAMSHAFT BUSHING INSTALLATION	OHT3F-019-2
TOOL, OIL PUMP PRIMER	OHT3F-038-1
Tube, throttle body to fuel pressure regulator	24505671

A3. SEQUENCE IIIG DETERMINATION VOLUME OF ENGINE OIL IN PAN

A3.1 Determine the volume of engine oil in the pan from
 Table A3.1 or Fig. A3.1.

TABLE A3.1 Oil Volume Look-Up Table

mm	mL	mm	mL	mm	mL
1	5153	51	3313	101	1635
2	5115	52	3278	102	1603
3	5077	53	3243	103	1571
4	5038	54	3208	104	1539
5	5000	55	3173	105	1508
6	4962	56	3138	106	1476
7	4924	57	3103	107	1444
8	4886	58	3069	108	1413
9	4848	59	3034	109	1381
10	4810	60	2999	110	1350
11	4773	61	2965	111	1318
12	4735	62	2930	112	1287
13	4697	63	2896	113	1256
14	4659	64	2861	114	1225
15	4622	65	2827	115	1194
16	4584	66	2793	116	1163
17	4547	67	2759	117	1132
18	4510	68	2725	118	1101
19	4472	69	2690	119	1070
20	4435	70	2657	120	1039
21	4398	71	2623	121	1009
22	4361	72	2589	122	978
23	4324	73	2555	123	947
24	4287	74	2521	124	917
25	4250	75	2488	125	886
26	4213	76	2454	126	856
27	4176	77	2420	127	826
28	4140	78	2387	128	796
29	4103	79	2353	129	765
30	4067	80	2320	130	735
31	4030	81	2287	131	705
32	3994	82	2254	132	675
33	3957	83	2220	133	645
34	3921	84	2187	134	615
35	3885	85	2154	135	586
36	3848	86	2121	136	556
37	3812	87	2089	137	526
38	3776	88	2056	138	497
39	3740	89	2023	139	467
40	3704	90	1990	140	438
41	3668	91	1958	141	408
42	3633	92	1925	142	379
43	3597	93	1893	143	350
44	3561	94	1860	144	320
45	3526	95	1828	145	291
46	3490	96	1795	146	262
47	3455	97	1763	147	233
48	3419	98	1731	148	204
49	3384	99	1699	149	175
50	3349	100	1667	150	146

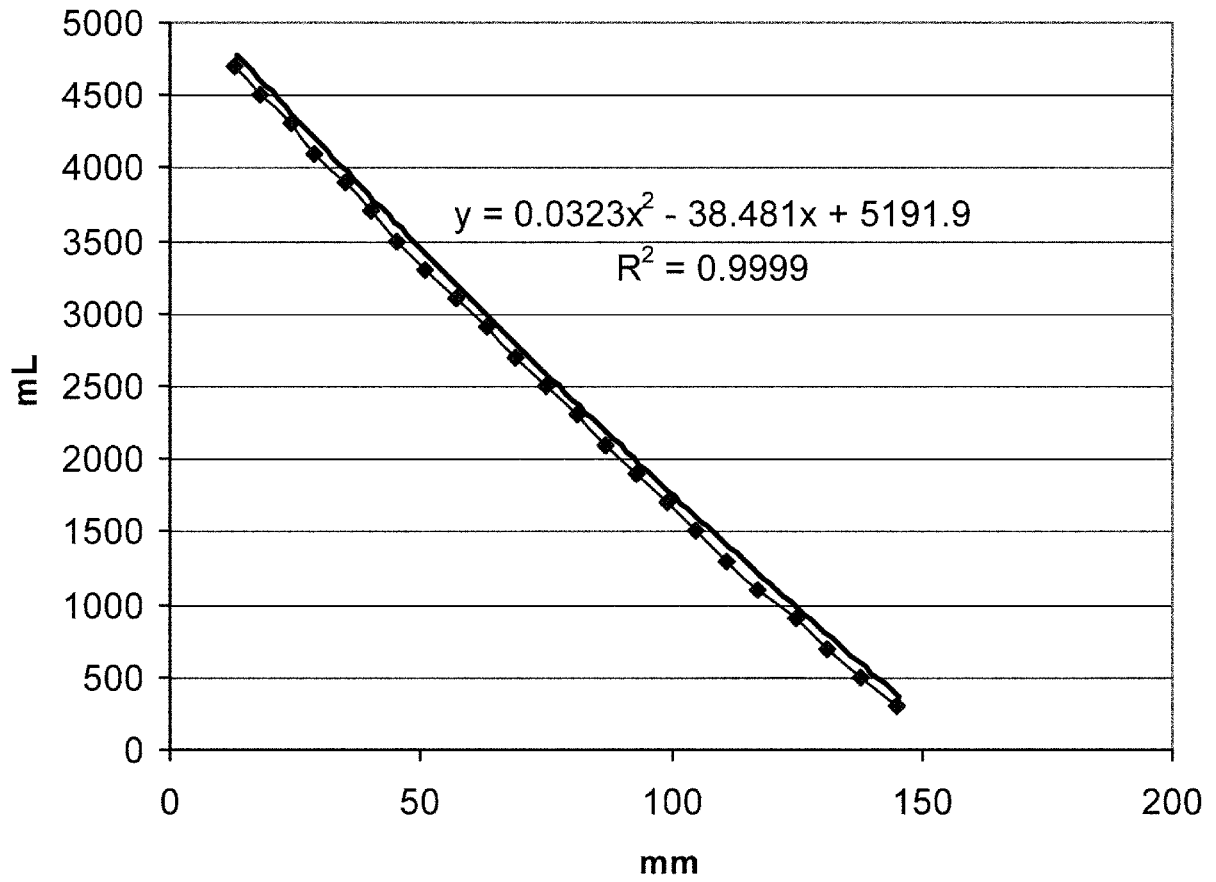

FIG. A3.1 Sequence III G Engine Oil Dipstick Calibration Curve

A4. SEQUENCE III G TEST FUEL ANALYSIS

TABLE A4.1 Sequence III Test Fuel Analysis (Haltermann HF003 Test Fuel)

TEST	METHOD	UNITS	HALTERMANN HF003 Specs		
			MIN	TARGET	MAX
Distillation - IBP	ASTM D86	°C	23.9		35
5%		°C			
10%		°C	48.9		57.2
20%		°C			
30%		°C			
40%		°C			
50%		°C	93.3		110.0
60%		°C			
70%		°C			
80%		°C			
90%		°C	151.7		162.8
95%	°C				
Distillation - EP		°C			212.8
Recovery		vol %		Report	
Residue		vol %		Report	
Loss		vol %		Report	
API Gravity (@60°F/60°F)	ASTM D4052	°API	58.7		61.2
Density (@15°C)	ASTM D4052	kg/L	0.734		0.744
Reid Vapor Pressure	ASTM D5191	kPa	60.8		63.4
Reid Vapor Pressure	ASTM D3231	kPa		Report	
Carbon	ASTM D3343	wt fraction		Report	
Carbon	ASTM E191	wt fraction		Report	
Hydrogen	ASTM E191	wt fraction		Report	
Hydrogen/Carbon ratio	ASTM E191	mole/mole		Report	
Oxygen	ASTM D4815	wt %			0.05
Sulfur ppm	ASTM D5453	mg/kg	3		15
Lead	ASTM D3237	mg/L			2.6
Phosphorus	ASTM D3231	mg/L			1.3
Composition, aromatics	ASTM D1319	vol %	26.0		32.5
Composition, olefins	ASTM D1319	vol %			10.0
Composition, saturates	ASTM D1319	vol %		Report	
Particulate matter	ASTM D5452	mg/L			1
Oxidation Stability	ASTM D525	minutes	240		
Copper Corrosion	ASTM D130				1
Gum content, washed	ASTM D381	mg/100mL			5
Fuel Economy Numerator/C Density	ASTM E191		2401		2441
C Factor	ASTM E191			Report	
Research Octane Number	ASTM D2699		96.0		
Motor Octane Number	ASTM D2700			Report	
Sensitivity			7.5		
Net Heating Value	ASTM D3338	J/kg		Report	
Net Heating Value	ASTM D240	J/kg		Report	
Color	VISUAL	1.75 ptb		Red	

A5. SEQUENCE IIIG TEST REPORT FORMS AND DATA DICTIONARY

A5.1 Download the actual report forms and data dictionary separately from the ASTM Test Monitoring Center Web Page at <ftp://astmtmc.cmu.edu/datadict/>; or obtain them in hardcopy format from the TMC.²

TABLE A5.1 Sequence IIIG Forms

Table of Contents		
1. Title/Validity Declaration Page		Form 1
2. Summary of Test Method		Form 3
3. Test Result Summary		Form 4
4. Operational Summary		Form 5
5. Viscosity and ICP Analytical Test Results		Form 6
6. Valve Lifter and Camshaft Wear Results		Form 7
7. Summary of Oil Ring Land Deposit Rating		Form 8
8. Summary of Weighted Piston Deposits		Form 9
9. Blowby Values and Plot		Form 10
10. Viscosity Increase Plot		Form 11
11. Hardware Information		Form 12
12. Downtime and Outlier Report Form		Form 13

A6. AIR-TO-FUEL RATIO CONTROL FLOW CHART

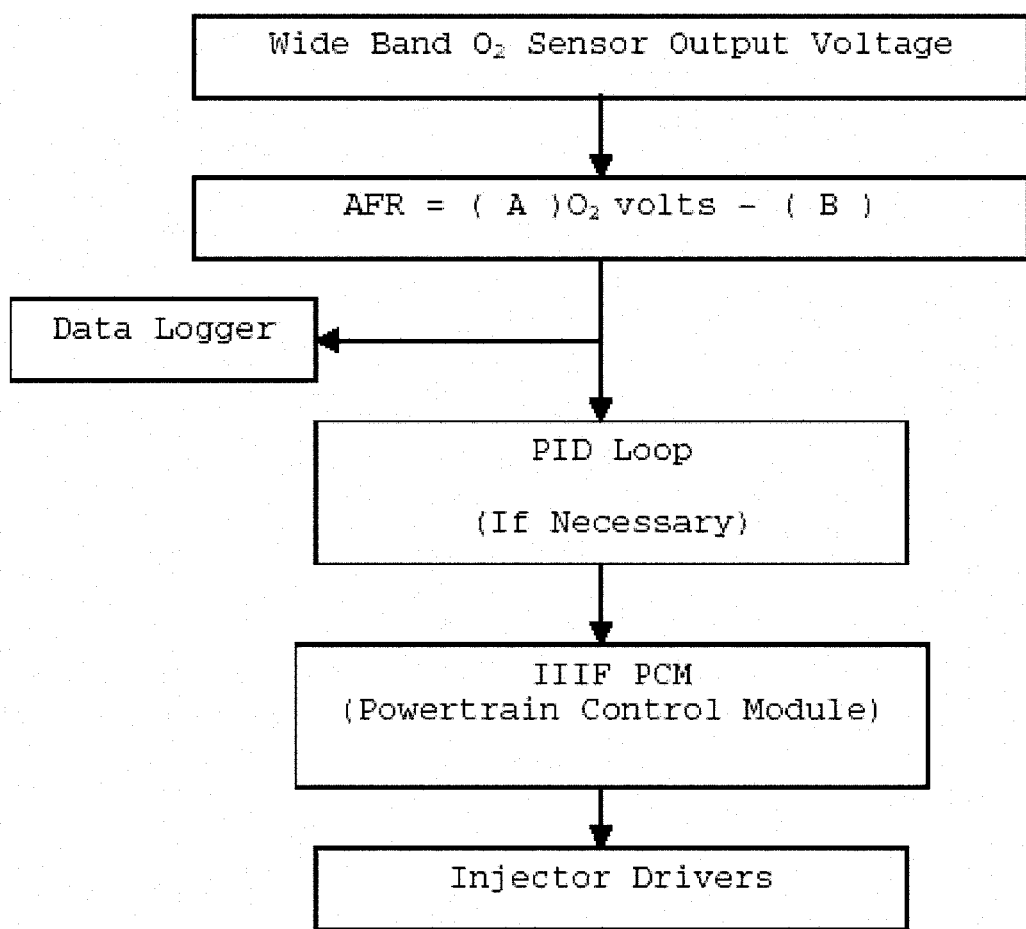

A & B derived from sensor calibration procedure and scaled to oscillating voltage from 100mv to 900mv input to PCM. Adjust B term as necessary during first hour of test condition to control at 15:1 air-to-fuel ratio.

FIG. A6.1 Air-to-Fuel Ratio Control Flow Chart

TABLE A6.1 Sequence III G Air-to-Fuel Ratio for Specified Fuel (CH_{1.860})_x

Composition by Weight:		%C	%H	Stoichiometric AFR:			14.530
		86.50	13.50				
Equivalence Ratios			Emissions by Volume (Dry)				Moisture
AFR	Lambda	Gamma	%O ₂	%H ₂	%CO	%CO ₂	%H ₂ O
7.265	0.500	2.000	0.000	13.635	19.975	2.968	7.249
7.555	0.520	1.923	0.000	12.357	19.179	3.387	7.372
7.846	0.540	1.852	0.000	11.536	18.379	3.817	8.344
8.137	0.560	1.786	0.000	10.571	17.575	4.258	8.868
8.427	0.580	1.724	0.000	9.660	16.767	4.709	9.346
9.718	0.600	1.667	0.000	8.803	15.954	5.170	9.780
9.008	0.620	1.613	0.000	7.997	15.137	5.641	10.173
9.299	0.640	1.562	0.000	7.241	14.317	6.122	10.526
9.589	0.660	1.515	0.000	6.533	13.494	6.611	10.843
9.890	0.680	1.471	0.000	5.872	12.670	7.107	11.125
10.171	0.700	1.429	0.000	5.256	11.844	7.611	11.374
10.461	0.720	1.389	0.000	4.682	11.018	8.120	11.593
10.752	0.740	1.351	0.000	4.149	10.192	8.634	11.783
11.042	0.760	1.326	0.000	3.655	9.369	9.153	11.947
11.333	0.780	1.282	0.000	3.197	8.549	9.674	12.086
11.624	0.800	1.250	0.000	2.774	7.732	10.196	12.202
11.914	0.820	1.220	0.000	2.382	6.921	10.720	12.297
12.205	0.840	1.190	0.000	2.021	6.116	11.243	12.373
12.495	0.860	1.163	0.000	1.689	5.319	11.765	12.432
12.786	0.880	1.136	0.000	1.383	4.525	12.285	12.474
13.077	0.900	1.112	0.000	1.101	3.740	12.802	12.502
13.367	0.920	1.087	0.000	0.842	2.977	13.315	12.517
13.658	0.940	1.064	0.000	0.604	2.216	13.824	12.519
13.948	0.960	1.042	0.000	0.385	1.456	14.327	12.511
14.239	0.980	1.020	0.000	0.184	0.727	14.825	12.494
14.530	1.000	1.000	0.000	0.000	0.000	15.317	12.467
14.820	1.020	0.980	0.439	0.000	0.000	14.996	12.230
15.111	1.040	0.962	0.861	0.000	0.000	14.688	12.017
15.401	1.060	0.943	1.265	0.000	0.000	14.392	11.803
15.692	1.080	0.926	1.653	0.000	0.000	14.109	11.597
15.982	1.100	0.909	2.027	0.000	0.000	13.835	11.398
16.273	1.120	0.893	2.386	0.000	0.000	13.572	11.206
16.564	1.140	0.877	2.732	0.000	0.000	13.320	11.021
16.854	1.160	0.862	3.065	0.000	0.000	13.076	10.841
17.145	1.180	0.847	3.386	0.000	0.000	12.841	10.657
17.435	1.200	0.833	3.696	0.000	0.000	12.614	10.498
17.726	1.220	0.820	3.995	0.000	0.000	12.396	10.335
18.017	1.240	0.806	4.284	0.000	0.000	12.185	10.177
18.307	1.260	0.794	4.563	0.000	0.000	11.980	10.024
18.598	1.280	0.781	4.833	0.000	0.000	11.783	9.875
18.888	1.300	0.769	5.094	0.000	0.000	11.592	9.730
19.179	1.320	0.758	5.347	0.000	0.000	11.407	9.590
19.470	1.340	0.746	5.592	0.000	0.000	11.228	9.453
19.760	1.360	0.735	5.830	0.000	0.000	11.054	9.321
20.051	1.380	0.725	6.060	0.000	0.000	10.886	9.192
20.341	1.400	0.714	6.283	0.000	0.000	10.723	9.067
20.632	1.420	0.704	6.500	0.000	0.000	10.564	8.945
20.923	1.440	0.694	6.710	0.000	0.000	10.410	8.826
21.213	1.460	0.685	6.915	0.000	0.000	10.261	8.710
21.504	1.480	0.676	7.113	0.000	0.000	10.116	8.598
21.794	1.500	0.667	7.306	0.000	0.000	9.975	8.488

Theoretical Exhaust Gas Relationships for Specified EEE Test Fuel

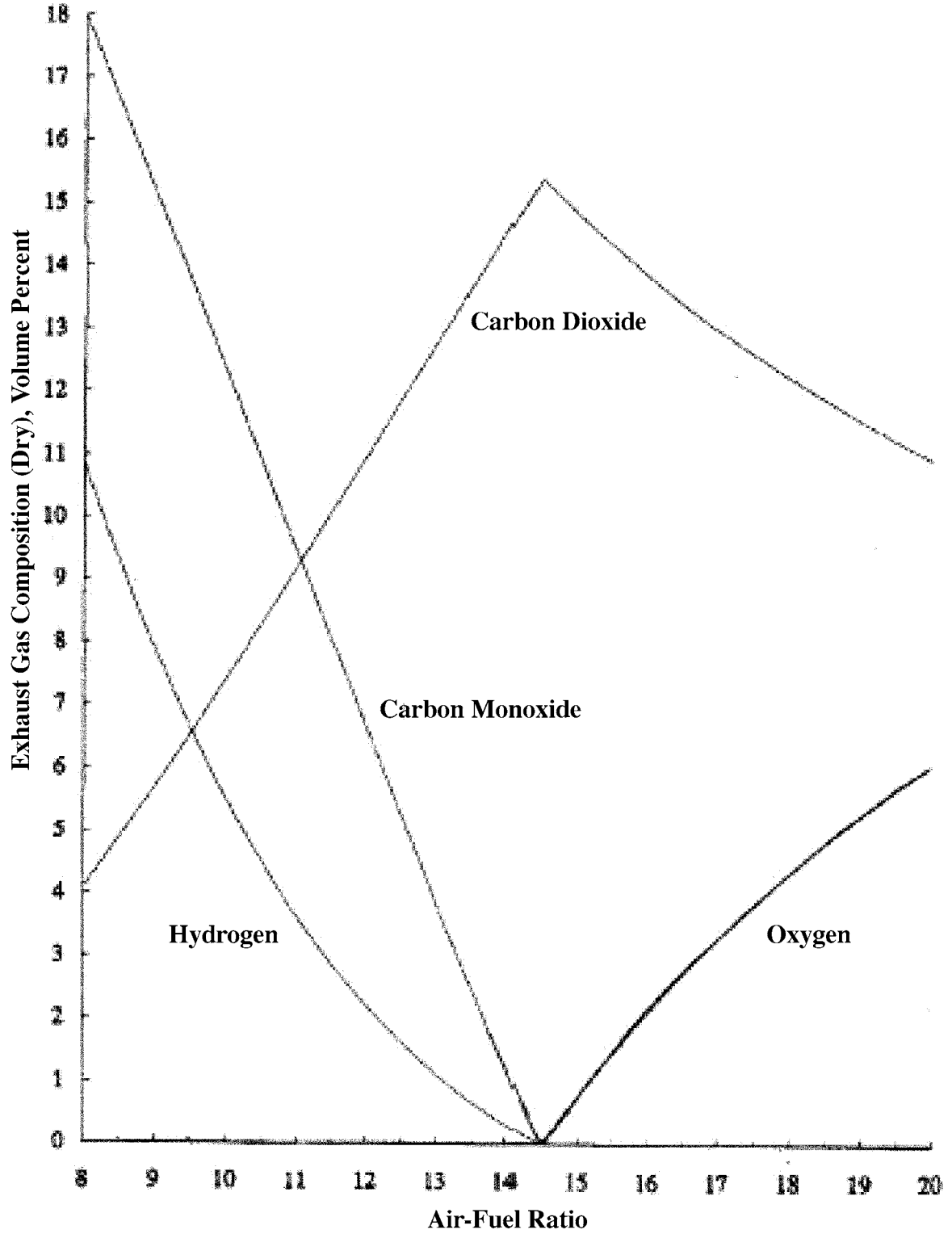

NOTE—Use corrected values for oxygen and carbon dioxide (see text).
 FIG. A6.2 Sequence IIIG Air-to-Fuel Ratio for Specified Fuel (C H_{1.860})_x

A7. SEQUENCE IIIG TEST SET POINTS AND CONTROL STATES
TABLE A7.1 Sequence IIIG On-Test Control Settings

Test Parameter	Set Point	Units	Acronym
Engine Speed	3600	r/min	SPEED
Dyno Torque	250	N-m	TORQUE
<i>Temperature</i>			
Oil Filter Block	150	°C	TOLFLT
Oil Sump	R	°C	TOLSMP
Engine Coolant Out	115	°C	TCLEO
Engine Coolant In	R	°C	TCLEI
Inlet Air Adapter	35	°C	TAIRIN
Dew point	16.1	°C	DEWPT
Breather Tube Coolant Outlet	40	°C	TCOND
Blowby Gas Outlet	R	°C	TBLBY
Fuel	R	°C	TFUELIN
Ambient Air	R	°C	TAMB
Right Exhaust Manifold Coolant Out	R	°C	TMMRO
Left Exhaust Manifold Coolant Out	R	°C	TMMLO
<i>Pressure</i>			
Oil Filter Inlet	R	KPa	POLFTR
Oil Gallery	R	kPa	POLENG
Fuel	377.5	kPa	PFUEL
Inlet Air Adapter	0.05	kPa	PAIRIN
Intake Manifold Vacuum	R	kPa	PINVAC
Crankcase	R	kPa	PCC
Exhaust Back Pressure Right	6	kPa	PEXHBR
Exhaust Back Pressure Left	6	kPa	PEXHBL
<i>Flow</i>			
Engine Coolant	160	L/min	FCLEO
Breather Tube	10	L/min	FCOND
Exhaust Manifold Left	8	L/min	FMML
Exhaust Manifold Right	8	L/min	FMMR
<i>AFR</i>			
Air-to-Fuel Ratio Left	15.0:1		AFRL
Air-to-Fuel Ratio Right	15.0:1		AFRR

**Seq. IIIG Test States
Dyno Speed**

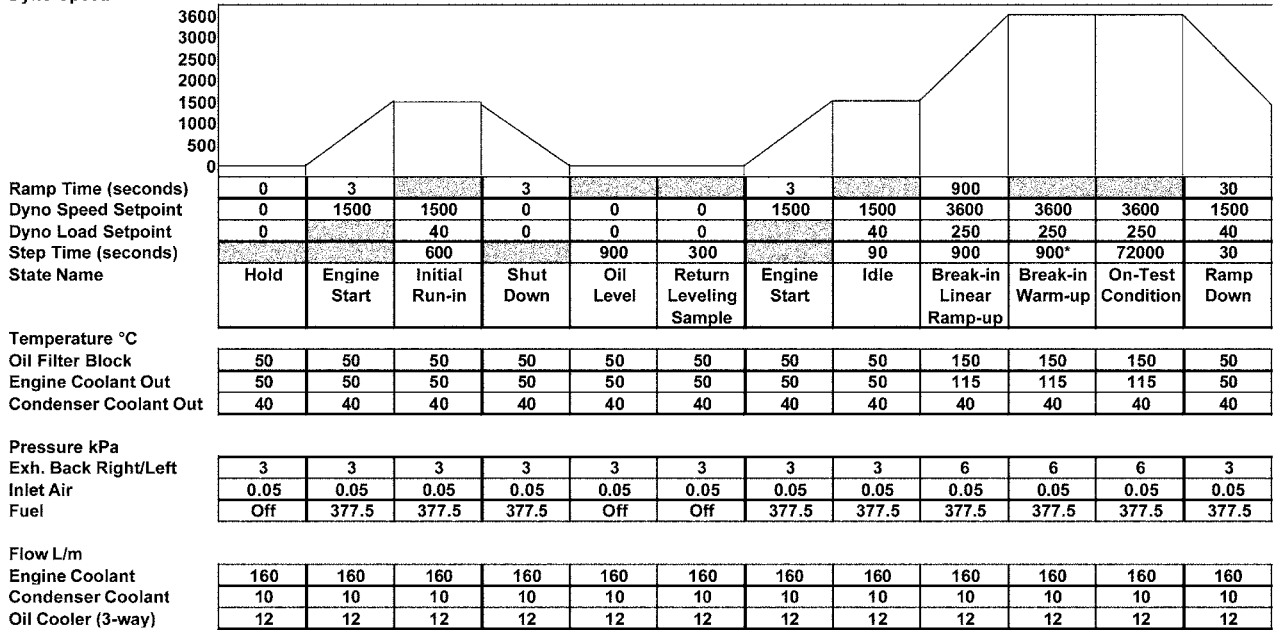

* Typical warm-up transition time to on test condition about 8 minutes.
 ** Typical warm-up transition time to on test condition about 18 minutes.
 All ramp times are linear with respect to dyno speed and load settings.
 All temp., press., and flow settings are setpoint changes between states. Control systems should allow for overshoot and stabilization.

FIG. A7.1 Sequence IIIG Operating Procedure and Specifications

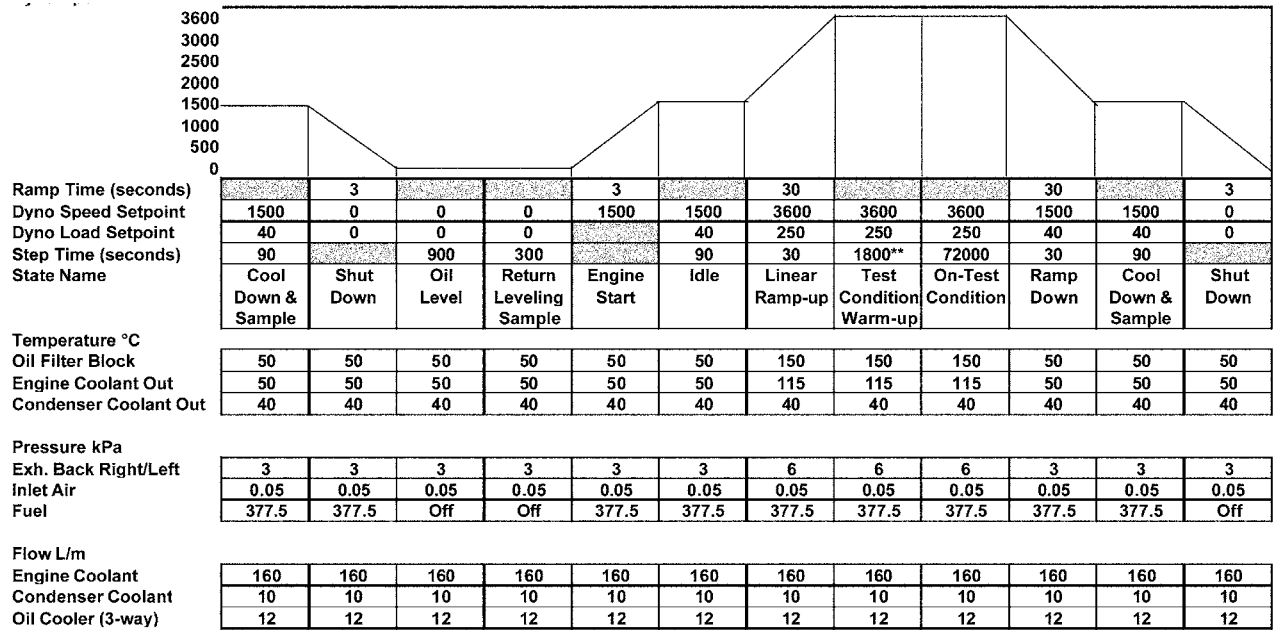

* Typical warm-up transition time to on test condition about 8 minutes.
 ** Typical warm-up transition time to on test condition about 18 minutes.
 All ramp times are linear with respect to dyno speed and load settings.
 All temp., press., and flow settings are setpoint changes between states. Control systems should allow for overshoot and stabilization.

FIG. A7.1 Sequence IIIG Operating Procedure and Specifications (continued)

A8. SEQUENCE IIIG QUALITY INDEX UPPER AND LOWER VALUES
TABLE A8.1 Sequence IIIG Quality Index Upper and Lower Values

NOTE—According to TMC Memo 03-061 based on Surveillance Panel agreement using IIIG Precision Matrix Data.

Controlled Parameters	Quality Index Upper and Lower Values	
	L	U
Speed	3595	3605
Torque	249.02	250.98
Air-to-Fuel Ratio	14.87	15.13
Condenser Coolant Outlet Temperature	39.77	40.23
Engine Coolant Outlet Temperature	114.54	115.46
Oil Filter Block Temperature	149.58	150.42
Exhaust Back Pressure	5.92	6.08
Intake Air Pressure	0.041	0.059
Engine Coolant Flow	158.57	161.43

TABLE A8.2 Sequence IIIG Required Resolution for Data Acquisition

Controlled Parameters	Units	Required Resolution ^A
Speed	r/min	5.0
Torque	N-m	5.1
Air-to-Fuel Ratio	–	5.2
Condenser Coolant Outlet Temperature	°C	5.1
Engine Coolant Outlet Temperature	°C	5.1
Oil Filter Block Temperature	°C	5.1
Exhaust Back Pressure	kPa	5.2
Intake Air Pressure	kPa	5.3
Condenser Coolant Flow	L/min	5.2
Engine Coolant Flow	L/min	5.1

^A Decimal point is counted in format.

TABLE A8.3 Maximum System Time Response^A

Speed	0.10 s
Torque	0.60 s
Coolant Flow	8.0 s
Intake Air Pressure	0.75 s
Exhaust Backpressure	1.20 s
Temperatures	2.40 s

^A For controlled (QI) parameters only.

A9. ENGINE OIL LEVEL WORK SHEET

Test Number: _____							EOT	
Oil Sample: _____	mL = Initial Oil Level					TOTAL		
Initial Fill = 5.50L = 5500 mL	Run In	20	40	60	80	100		
Remove 472 mL Purge Sample	<input type="checkbox"/>					<input type="checkbox"/>		
Remove 472 mL Leveling Sample	<input type="checkbox"/>	<input type="checkbox"/>	<input type="checkbox"/>	<input type="checkbox"/>	<input type="checkbox"/>			
Remove 236 mL Analysis Sample	<input type="checkbox"/>					<input type="checkbox"/>		
Remove 59 mL Analysis Sample	<input type="checkbox"/>	<input type="checkbox"/>	<input type="checkbox"/>	<input type="checkbox"/>	<input type="checkbox"/>			
Replace 472 mL Purge Sample	<input type="checkbox"/>					<input type="checkbox"/>		
Add 59 mL to Replace Sample		<input type="checkbox"/>	<input type="checkbox"/>	<input type="checkbox"/>	<input type="checkbox"/>			
Add 472 mL New Oil		<input type="checkbox"/>	<input type="checkbox"/>	<input type="checkbox"/>	<input type="checkbox"/>			
Dipstick Level After Draindown (mm)								A
Leveling Sample Added (mL)								
Leveling Sample Discarded (mL)								
Resulting Dipstick Level (mm)								
Computed Oil Level, Low (mL)								C
Performed By: _____								

Total Oil Consumption = Total 472 mL New Oil Additions (A) - Total Sample Discarded (B) + EOT Oil Level Low (C) - 236 mL

FIG. A9.1 Engine Oil Level Data Sheet

A10. BLOWBY FLOW RATE DETERMINATION

TABLE A10.1 Blowby Flow Rate Correction Factor

Pressure, kPa	Temperature, °C															
	15	16	17	18	19	20	21	22	23	24	25	26	27	28	29	30
105.0	1.064	1.062	1.061	1.059	1.057	1.055	1.053	1.052	1.050	1.048	1.046	1.045	1.043	1.041	1.039	1.039
104.5	1.062	1.060	1.058	1.056	1.054	1.053	1.051	1.049	1.047	1.046	1.044	1.042	1.040	1.039	1.037	1.035
104.0	1.059	1.057	1.056	1.054	1.052	1.050	1.048	1.047	1.045	1.043	1.041	1.040	1.038	1.036	1.034	1.033
103.5	1.057	1.055	1.053	1.051	1.049	1.048	1.046	1.044	1.042	1.041	1.039	1.037	1.035	1.034	1.032	1.030
103.0	1.054	1.052	1.050	1.049	1.047	1.045	1.043	1.042	1.040	1.038	1.036	1.035	1.033	1.031	1.029	1.028
102.5	1.052	1.050	1.048	1.046	1.044	1.043	1.041	1.039	1.037	1.035	1.034	1.032	1.030	1.029	1.027	1.025
102.0	1.049	1.047	1.045	1.044	1.042	1.040	1.038	1.036	1.035	1.033	1.031	1.030	1.028	1.026	1.024	1.023
101.5	1.046	1.045	1.043	1.041	1.039	1.037	1.036	1.034	1.032	1.030	1.029	1.027	1.025	1.024	1.022	1.020
101.0	1.044	1.042	1.040	1.038	1.037	1.035	1.033	1.031	1.030	1.028	1.026	1.024	1.023	1.021	1.019	1.018
100.5	1.041	1.039	1.038	1.036	1.034	1.032	1.031	1.029	1.027	1.025	1.024	1.022	1.020	1.019	1.017	1.015
100.0	1.039	1.037	1.035	1.033	1.031	1.030	1.028	1.026	1.025	1.023	1.021	1.019	1.018	1.016	1.014	1.013
99.5	1.036	1.034	1.032	1.031	1.029	1.027	1.025	1.024	1.022	1.020	1.019	1.017	1.015	1.013	1.012	1.010
99.0	1.033	1.032	1.030	1.028	1.026	1.025	1.023	1.021	1.019	1.018	1.016	1.014	1.013	1.011	1.009	1.008
98.5	1.031	1.029	1.027	1.025	1.024	1.022	1.020	1.019	1.017	1.015	1.013	1.012	1.010	1.008	1.007	1.005
98.0	1.020	1.026	1.025	1.023	1.021	1.019	1.018	1.016	1.014	1.013	1.011	1.009	1.007	1.006	1.004	1.002
97.5	1.026	1.024	1.022	1.020	1.019	1.017	1.015	1.013	1.012	1.010	1.008	1.007	1.005	1.003	1.002	1.000
97.0	1.023	1.021	1.019	1.018	1.016	1.014	1.012	1.011	1.009	1.007	1.006	1.004	1.002	1.001	0.999	0.997
96.5	1.020	1.019	1.017	1.015	1.013	1.012	1.010	1.008	1.006	1.005	1.003	1.001	1.000	0.998	0.996	0.995
96.0	1.018	1.016	1.014	1.012	1.011	1.009	1.007	1.006	1.004	1.002	1.000	0.999	0.997	0.995	0.994	0.992
95.5	1.015	1.013	1.011	1.010	1.008	1.006	1.005	1.003	1.001	1.000	0.998	0.996	0.994	0.993	0.991	0.990
95.0	1.012	1.011	1.009	1.007	1.005	1.004	1.002	1.000	0.999	0.997	0.995	0.994	0.992	0.990	0.989	0.987
94.5	1.010	1.008	1.006	1.004	1.003	1.001	0.999	0.998	0.996	0.994	0.993	0.991	0.989	0.988	0.985	0.984
94.0	1.007	1.005	1.004	1.002	1.000	0.998	0.997	0.995	0.993	0.992	0.990	0.988	0.987	0.985	0.983	0.982
	31	32	33	34	35	36	37	38	39	40	41	42	43	44	45	
105.0	1.036	1.034	1.033	1.031	1.029	1.028	1.026	1.024	1.023	1.021	1.019	1.018	1.016	1.014	1.013	
104.5	1.033	1.032	1.030	1.028	1.027	1.025	1.023	1.022	1.020	1.018	1.017	1.015	1.014	1.012	1.010	
104.0	1.031	1.029	1.028	1.026	1.024	1.023	1.021	1.019	1.018	1.016	1.014	1.013	1.011	1.010	1.008	
103.5	1.028	1.027	1.025	1.023	1.022	1.020	1.018	1.017	1.015	1.014	1.012	1.010	1.009	1.007	1.006	

TABLE A10.1 *Continued*

Pressure, kPa	Temperature, °C														
	46	47	48	49	50	51	52	53	54	55	56	57	58	59	60
103.0	1.026	1.024	1.023	1.021	1.019	1.018	1.016	1.014	1.013	1.011	1.010	1.008	1.006	1.005	1.003
102.5	1.024	1.022	1.020	1.018	1.017	1.015	1.014	1.012	1.010	1.009	1.007	1.005	1.004	1.002	1.001
102.0	1.021	1.019	1.018	1.016	1.014	1.013	1.011	1.009	1.008	1.006	1.005	1.003	1.001	1.000	0.998
101.5	1.019	1.017	1.015	1.014	1.012	1.010	1.009	1.007	1.005	1.004	1.002	1.001	0.999	0.997	0.996
101.0	1.016	1.014	1.013	1.011	1.009	1.008	1.006	1.005	1.003	1.001	1.000	0.998	0.997	0.995	0.993
100.5	1.013	1.012	1.010	1.009	1.007	1.005	1.004	1.002	1.000	0.999	0.997	0.996	0.994	0.992	0.991
100.0	1.011	1.009	1.008	1.006	1.004	1.003	1.001	1.000	0.998	0.996	0.995	0.993	0.992	0.990	0.988
99.5	1.008	1.007	1.005	1.003	1.002	1.000	0.999	0.997	0.995	0.994	0.992	0.991	0.989	0.988	0.986
99.0	1.006	1.004	1.003	1.001	0.999	0.998	0.996	0.995	0.993	0.991	0.990	0.988	0.987	0.985	0.984
98.5	1.003	1.002	1.000	0.998	0.997	0.995	0.994	0.992	0.990	0.989	0.987	0.986	0.984	0.983	0.981
98.0	1.001	0.999	0.998	0.996	0.994	0.993	0.991	0.989	0.988	0.986	0.985	0.983	0.982	0.980	0.979
97.5	0.998	0.997	0.995	0.993	0.992	0.990	0.989	0.987	0.985	0.984	0.982	0.981	0.979	0.978	0.976
97.0	0.996	0.994	0.992	0.991	0.989	0.988	0.986	0.984	0.983	0.981	0.980	0.978	0.977	0.975	0.974
96.5	0.993	0.991	0.990	0.988	0.987	0.985	0.983	0.982	0.980	0.979	0.977	0.976	0.975	0.973	0.971
96.0	0.991	0.989	0.987	0.986	0.984	0.982	0.981	0.979	0.978	0.976	0.975	0.973	0.972	0.970	0.968
95.5	0.988	0.986	0.985	0.983	0.982	0.980	0.978	0.977	0.975	0.974	0.972	0.971	0.969	0.967	0.966
95.0	0.985	0.984	0.982	0.981	0.979	0.977	0.976	0.974	0.973	0.971	0.970	0.968	0.966	0.965	0.963
94.5	0.983	0.981	0.980	0.978	0.976	0.975	0.973	0.972	0.970	0.969	0.967	0.965	0.964	0.962	0.961
94.0	0.988	0.979	0.977	0.975	0.974	0.972	0.971	0.969	0.968	0.966	0.964	0.963	0.961	0.960	0.958
	46	47	48	49	50	51	52	53	54	55	56	57	58	59	60
105.0	1.011	1.010	1.008	1.007	1.005	1.003	1.002	1.000	0.999	0.997	0.996	0.994	0.993	0.991	0.990
104.5	1.009	1.007	1.006	1.004	1.003	1.001	1.000	0.998	0.996	0.995	0.993	0.992	0.990	0.989	0.987
104.0	1.006	1.005	1.003	1.002	1.000	0.999	0.997	0.996	0.994	0.993	0.991	0.990	0.988	0.987	0.985
103.5	1.004	1.002	1.001	0.999	0.998	0.996	0.995	0.993	0.992	0.990	0.989	0.987	0.986	0.984	0.983
103.0	1.002	1.000	0.998	0.997	0.995	0.994	0.992	0.991	0.989	0.988	0.986	0.985	0.983	0.982	0.980
102.5	0.999	0.998	0.996	0.995	0.993	0.991	0.990	0.988	0.987	0.985	0.984	0.982	0.981	0.979	0.978
102.0	0.997	0.995	0.994	0.992	0.991	0.989	0.988	0.986	0.984	0.983	0.981	0.980	0.979	0.977	0.976
101.5	0.994	0.993	0.991	0.990	0.988	0.987	0.985	0.984	0.982	0.981	0.979	0.978	0.976	0.975	0.973
101.0	0.992	0.990	0.989	0.987	0.986	0.984	0.983	0.981	0.980	0.978	0.977	0.975	0.974	0.972	0.971
100.5	0.989	0.988	0.986	0.985	0.983	0.982	0.980	0.979	0.977	0.976	0.974	0.973	0.971	0.970	0.968
100.0	0.987	0.985	0.984	0.982	0.981	0.979	0.978	0.976	0.975	0.973	0.972	0.970	0.969	0.967	0.965
99.5	0.984	0.983	0.981	0.980	0.978	0.977	0.975	0.974	0.972	0.971	0.969	0.968	0.966	0.965	0.964
99.0	0.982	0.980	0.979	0.977	0.976	0.974	0.973	0.971	0.970	0.968	0.967	0.965	0.964	0.963	0.961
98.5	0.979	0.978	0.976	0.975	0.973	0.972	0.970	0.969	0.967	0.966	0.965	0.963	0.962	0.960	0.959
98.0	0.977	0.975	0.974	0.972	0.971	0.969	0.968	0.966	0.965	0.964	0.962	0.961	0.959	0.958	0.956
97.5	0.975	0.973	0.971	0.970	0.968	0.967	0.965	0.964	0.963	0.961	0.960	0.958	0.957	0.955	0.954
97.0	0.972	0.970	0.969	0.967	0.966	0.964	0.963	0.962	0.960	0.959	0.957	0.956	0.954	0.953	0.951
96.5	0.969	0.968	0.966	0.965	0.963	0.962	0.961	0.959	0.958	0.956	0.955	0.953	0.952	0.950	0.949
96.0	0.967	0.965	0.964	0.962	0.961	0.959	0.958	0.957	0.955	0.954	0.952	0.951	0.949	0.948	0.946
95.5	0.964	0.963	0.961	0.960	0.958	0.957	0.956	0.954	0.953	0.951	0.950	0.948	0.947	0.945	0.944
95.0	0.962	0.960	0.959	0.957	0.956	0.954	0.953	0.952	0.950	0.949	0.947	0.946	0.944	0.943	0.942
94.5	0.959	0.958	0.956	0.955	0.953	0.952	0.951	0.949	0.948	0.946	0.945	0.943	0.942	0.940	0.939
94.0	0.957	0.955	0.954	0.952	0.951	0.949	0.948	0.947	0.945	0.944	0.942	0.941	0.939	0.938	0.937

A11. SAFETY HAZARDS

A11.1 General Information

A11.1.1 The operating of engine tests can expose personnel and facilities to a number of safety hazards. Only personnel who are thoroughly trained and experienced in engine testing should undertake the design, installation, and operations of engine test stands.

A11.1.2 Each laboratory conducting engine tests should have their test installation inspected and approved by their Safety Department. Personnel working on the engines should be provided with proper tools, be alert to common sense safety practices, and avoid contact with moving, or hot engine parts. Guards should be installed around all external moving or hot parts. When engines are operating at high speeds, heavy-duty guards are required, and personnel should be cautioned against working alongside the engine and coupling shaft. Barrier protection should be provided for personnel. All fuel lines, oil lines, and electrical wiring should be properly routed, guarded, and kept in good order. Scraped knuckles, minor burns, and cuts are common occurrences, if proper safety precautions are not taken. Safety masks or glasses should always be worn by personnel working on the engines and no loose or flowing clothing, including long hair or other accessory to dress which could become entangled, should be worn near running engines.

A11.1.3 The external parts of the engines and the floor area around the engines should be kept clean and free of oil and fuel spills. In addition, all working areas should be free of tripping hazards. In case of injury, no matter how slight, first aid attention should be applied at once and the incident reported. Personnel should be alert for leaking fuel or exhaust gas. Leaking fuel represents a fire hazard and exhaust gas fumes are noxious. Containers of oil or fuel cannot be permitted to accumulate in the testing area.

A11.1.4 The test installation should be equipped with a fuel shut-off valve that is designed to automatically cut off the fuel supply to the engine when the engine is not running. A remote station for cutting off fuel from the test stand is recommended. Suitable interlocks should be provided to automatically shut-down the engine when any of the following events occur: engine loses oil pressure; dynamometer loses field current; engine overspeeds; exhaust system fails; room ventilation fails; or the fire protection system is activated.

A11.1.5 Consider an excessive vibration pickup interlock if equipment operates unattended. Fixed fire protection equipment should be provided.

A11.1.6 Normal precautions should be observed whenever using flammable solvents for cleaning purposes. Make sure adequate fire fighting equipment is immediately accessible.

A12. SEQUENCE IIIG BLUEPRINT LISTING

TABLE A12.1 Blueprint List^A

Print Number	Description
RX-116924-C	Flushing Tank
RX-117230-E	Flushing Tank System Piping Layout
RX-117231-C	Flushing Tank Schematic
RX-117350-D	Coolant Mixing Tank
RX-116169-A1, revision N	Flow Meter (multiple orifice) blowby
RX-118602-B	Ring Depth Gage
BX-310-2	Valve Spring Load Measurement Apparatus
RX-117431-C	Blowby Gas Surge Tank
RX-117294-A	Bushing, blowby adapter
RX-118137-C	Water in and out coolant flushing tank–Evertite
RX-118613-C	Oil Filter Adapter
RX-118457-B	Oil Filter Adapter Fitting

^A Available from the TMC.

A13. FLUID CONDITION MODULE COMPONENTS
TABLE A13.1 List of Components that have been Found Suitable for Use in the Fluid Condition Module

System	Component	Make	Model	Comments
Fuel	Pump	KFI	10210	12 VDC
	Flow Meter	Micro Motion		
	Pressure Regulator (on-rack)	Weldon	2040-200-A-170	
	Heat Exchanger	Elanco	M11	
	Check Valve	Sharpe	FNW-16	
	Solenoid Valve	Skinner	72218RN4UV00N0H222P3	
	Filter	Racor	110A	
Engine Coolant	Pump	Aurora	341ABF 1-1/2 x 2 x 9	
	Flow Meter	ABB/Fisher Porter	10VT1000	1111ADH11C12AA0A has been replaced
	Heat Exchanger	Elanco	M71FL	
	Heater	Chromalox	ARTMS-1250TL	
	3-Way Control Valve	SVF	T7-6666TT150-S1	2 in. Valve
	2-Way Control Valve	Orion/Badger Meter	9003GCW36SV3A29L36	2 in. Valve (same as used on Sequence VIB)
	Inlet Line I.D. / Total Length	2 in.	226 in.	Total run from Process Controller to Engine Inlet Adapter
Breather Tube	Pump	Aurora	133-BF-E03 1-3/4 x 3/4	
	Flow Meter	Sparling	FM625*	
	Heat Exchanger	Elanco	M21	
	Heater	Chromalox	3CVCHS-151	
	3-Way Control Valve	SVF	T7-6666TTSE-S1	1/2 -in. Valve
	2-Way Control Valve	SVF	V7-6666NTSE-V60	1/2 -in. Valve
	Oil Cooler	Pump	Aurora	133-BF-E03 1-3/4 x 3/4
Flow Meter		Sparling	FM625*	
3-Way Control Valve		SVF	T7-6666TTSE-S1	1/2 -in. Valve
2-Way Control Valve		SVF	V7-6666NTSE-V30	1/2 -in. Valve

A14. ENGINE BUILD WORKSHEETS

SEQUENCE III BUILD FORM

ENGINE ID : _____ BLOCK CODE: _____ REBUILDER ID : _____ DATE COMPLETED : _____ CAMSHAFT ID: _____ CONNECTING ROD TYPE (CAST or PM) _____ LIFTER SET ID : _____ LIFTER BATCH CODE : _____ PISTON BATCH CODE : _____ PISTON GRADE : _____ RING BATCH CODE : _____ RING GRADE : _____ WRIST PIN BATCH CODE : _____ PUSH ROD BATCH CODE : _____ ROCKER ARM BATCH CODE : _____	LEFT HEAD ID : _____ RIGHT HEAD ID : _____ BEARING SERIAL NUMBER ID : _____ CRANKSHAFT ID : _____ FRONT COVER ID : _____ MANIFOLD ID : _____ BREATHER TUBE ID : _____ OIL FILTER BATCH CODE : _____ KIT NUMBER: _____
--	---

COMMENTS : _____

CYLINDER BORE MEASUREMENTS

STANDARD CALIBRATION READING : _____

LOCATION	TOP	MIDDLE	BOTTOM	TAPER	LOCATION	TOP	MIDDLE	BOTTOM	TAPER
CYLINDER	#1				CYLINDER	#2			
LONG DIA. (mm)					LONG DIA.				
TRANS. DIA. (mm)					TRANS. DIA.				
DELTA					DELTA				
AVERAGE OUT : _____ AVERAGE TAPER : _____ MICROFINISH, Ra: _____					AVERAGE OUT : _____ AVERAGE TAPER : _____ MICROFINISH, Ra: _____				
CYLINDER	#3				CYLINDER	#4			
LONG DIA.					LONG DIA.				
TRANS. DIA.					TRANS. DIA.				
DELTA					DELTA				
AVERAGE OUT : _____ AVERAGE TAPER : _____ MICROFINISH, Ra: _____					AVERAGE OUT : _____ AVERAGE TAPER : _____ MICROFINISH, Ra: _____				
CYLINDER	#5				CYLINDER	#6			
LONG DIA.					LONG DIA.				
TRANS. DIA.					TRANS. DIA.				
DELTA					DELTA				
AVERAGE OUT : _____ AVERAGE TAPER : _____ MICROFINISH, Ra: _____					AVERAGE OUT : _____ AVERAGE TAPER : _____ MICROFINISH, Ra: _____				

FIG. A14.1 Engine Build Worksheet

SEQUENCE III BUILD FORM

ENGINE ID : _____

REBUILDER ID: _____

CYLINDER	COMPRESSION RING GAPS*		RING SIDE CLEARANCE		
	TOP, mm	2nd, mm	TOP .033-.079mm	2nd .033-.079mm	OIL .023-.201mm
1	_____	_____	_____	_____	_____
2	_____	_____	_____	_____	_____
3	_____	_____	_____	_____	_____
4	_____	_____	_____	_____	_____
5	_____	_____	_____	_____	_____
6	_____	_____	_____	_____	_____

*IIG ring gap spec: top (0.635 ± 0.051) mm, bottom (1.067 ± 0.051) mm

CRANKSHAFT MEASUREMENTS

JOURNAL #	CON ROD JOURNALS - SPEC: 57.1170 - 57.1475mm				MAIN JOURNALS - SPEC: 63.470 - 63.495mm		
	HORIZ.	VERT.	OUT OF RD.	SIDE CL. .102-.508mm	HORIZ.	VERT.	OUT OF RD.
1	_____	_____	_____	_____	_____	_____	_____
2	_____	_____	_____	_____	_____	_____	_____
3	_____	_____	_____	_____	_____	_____	_____
4	_____	_____	_____	_____	_____	_____	_____
5	_____	_____	_____	_____	_____	_____	_____
6	_____	_____	_____	_____	_____	_____	_____

CRANKSHAFT END PLAY _____ (spec: 0.076-0.276 mm)

OIL PUMP MEASUREMENTS

OIL PUMP GEAR DROP _____ (spec: 0.025-0.089 mm)

OIL PUMP GEAR TIP CLEARANCE _____ (spec: 0.076-0.127 mm)

OIL PMP OUTER GEAR DIA. CLEAR. _____ (spec: 0.025-0.127 mm)

VALVE TRAIN MEASUREMENTS

VALVE SPRINGS BATCH : _____

INTAKE VALVE SEALS BATCH : _____

EHXAUST VALVE SEALS BATCH: _____

CYLINDER HEAD SPRING CALIBRATION - 919 ± 45 N @ 9.5 mm deflection

	1 EX	1 INT	3 EX	3 INT	5 EX	5 INT
LT HEAD# :	_____	_____	_____	_____	_____	_____
SHIM SIZE :	_____	_____	_____	_____	_____	_____
	2 EX	2 INT	4 EX	4 INT	6 EX	6 INT
RT HEAD# :	_____	_____	_____	_____	_____	_____
SHIM SIZE :	_____	_____	_____	_____	_____	_____

FIG. A14.2 Engine Build Worksheet

APPENDIXES**(Nonmandatory Information)****X1. SEQUENCE IIIGA TEST PROCEDURE****X1.1 Overview:**

X1.1.1 The Sequence IIIGA test was developed to generate a used oil sample for subsequent testing of Apparent Viscosity in the Mini Rotary Viscometer using Test Method **D4684**. (This Apparent Viscosity result will hereafter be referred to as the MRV result or MRV.) No parts ratings or measurements are required in the Sequence IIIGA test. A separate Sequence IIIGA Report Form Set is available from the TMC for reporting Sequence IIIGA test results. The Sequence IIIG Report Form Set shall not be used to report Sequence IIIGA test results.

X1.2 *Preparation of Apparatus*—Prepare the Sequence IIIGA test engine in the same manner as a Sequence IIIG test engine. The lone exceptions being that the pre-test camshaft and lifter measurements are not required. No special preparations, other than the exception outlined above, are required or permitted on test engines for Sequence IIIGA use.

X1.3 Calibration:

X1.3.1 There is no stand-alone calibration system for the Sequence IIIGA test. For a stand to be considered calibrated for Sequence IIIGA testing it shall be calibrated for Sequence IIIG testing. A Sequence IIIGA test shall be conducted simultaneously with each Sequence IIIG test.

X1.3.2 No special calibration of stand instrumentation is required for Sequence IIIGA testing.

X1.3.3 No severity adjustments are calculated for MRV.

X1.3.4 A Sequence IIIGA test counts as one run against the Sequence IIIG calibration period in which it is run. A test run as a combined Sequence IIIG/Sequence IIIGA test counts as only one run against the calibration period.

X1.4 *Test Procedure*—The Sequence IIIGA test can be conducted in one of two ways:

X1.4.1 *Stand-alone Sequence IIIGA Test*—If only a Sequence IIIGA test result is needed, conduct the test in the normal manner as listed in this Test Method with the exception of ratings, wear measurements, or assessment of stuck rings. The oil sampling required in the Test Method shall still be performed, but no subsequent analysis (kinematic viscosity, ICP analysis) of those samples is required. Perform MRV and Cold Crank Simulator (CCS) measurements, Test Method **D5293**, on the final oil sample taken from the engine. The CCS result shall be used to set the temperature for performing the MRV measurement.

X1.4.2 *Combined Sequence IIIG/Sequence IIIGA Test*—If both Sequence IIIG and Sequence IIIGA test results are desired on an oil, conduct the test in the normal manner as listed in this Test Method, including all ratings, measurements, and used oil analyses. Once completed, perform MRV and Cold Crank Simulator (CCS) measurements, Test Method **D5293**, on the final oil sample taken from the engine and report these results

as the Sequence IIIGA results. Report the Sequence IIIG results in the normal manner.

X1.5 *End-of-Test Oil Sample Testing*—Conduct a Cold Cranking Simulator test (Test Method **D5293**) and a Mini Rotary Viscometer test (Test Method **D4684**) on the end-of-test (EOT) used oil sample with the following exceptions:

X1.5.1 For non-reference oils run a Cold Cranking Simulator (CCS) test (Test Method **D5293**) on the end-of-test (100 h) analysis sample at the temperature that is specified for the test oils given viscosity grade in Table 1 of SAE J300, Revised Dec 1999. Report results on Form 6, Used Oil Analysis Results, in the standardized report form set (see **Annex A5**).

X1.5.2 Run the Mini Rotary Viscometer test (Test Method **D4684**), MRV-TP1 at new oil viscosity grade using SAE J300 specifications if a passing CCS result is obtained. If the CCS fails, run the MRV at the same temperature as the CCS (one grade higher based on J300). Report the end-of-test Mini Rotary Viscometer test results along with the test temperature in degrees Celsius along with yield stress as follows: (1) If a yield stress is obtained at the designated temperature greater than 35 Pa, report the yield stress in pascals and note the apparent viscosity as not measured (NM). (2) If a yield stress is not obtained at the designated temperature exceeding 35 Pa, report the yield stress as “<35” to indicate that the yield stress did not exceed 35 Pa. (3) Report the results in the standardized report form set (see **Annex A5**).

X1.5.3 If the percent Viscosity Increase for the kinematic viscosity at EOT is higher than 500 percent, the CCS and the MRV tests are not required. A notation is required in the Other Comments and Outlier section of Form 13 (see **Annex A5**) indicating that the CCS and MRV were not run and enter not measured (NM) in the standardized report form set (see **Annex A5**).

X1.5.4 If the test oil is a straight grade oil, Cold-cranking Simulator and Mini-Rotary Viscometer tests are not required. A notation is required in the Other Comments & Outlier section of Form 13 (see **Annex A5**) indicating that the CCS and MRV were not run and enter not measured (NM) in the standardized form set (see **Annex A5**).

X1.5.5 It is required to start the MRV test within 168 h of EOT of the engine test.

X1.5.6 Upend the sample for MRV testing five times before starting the test.

X1.6 *Quality Index*—Calculations of quality index results for Sequence IIIGA test results shall be calculated in the same manner as Sequence IIIG test results.

X1.7 *Test Reporting*—Report Sequence IIIGA tests using the standard report form set, available from the TMC.

X1.8 *Precision and Bias*—The precision and bias of this test

TABLE X1.1 Sequence IIIGA Reference Oil Statistics^A

Variable	Intermediate Precision		Reproducibility	
	S _{i.p.}	i.p. ^B	S _R	R ^B
MRV Viscosity ^C	0.57	1.60	0.57	1.60

^A These statistics are based on results obtained on Test Monitoring Center Reference Oils 434, 435, and 438 over the period from August 12, 2003 through July 21, 2004.

^B This value is obtained by multiplying the standard deviation by 2.8.

^C This parameter is transformed using $\ln(\text{result})$. When comparing two test results on this parameter, this transformation must first be applied to each test result. Compare the absolute difference between the transformed results with the appropriate (intermediate precision or reproducibility) precision limit.

method for measuring Apparent Viscosity (MRV) are specified in Test Method **D4684**. The precision and bias of the engine test used to generate the IIIGA oil sample are as follows:

X1.8.1 Precision—Test precision is established based on reference oil test results (for operationally valid tests) monitored by the ASTM Test Monitoring Center. **Table X1.1** summarizes reference oil precision of the test based on results obtained with Test Monitoring Center Reference Oils.

X1.8.2 Intermediate Precision Conditions—Conditions where test results are obtained with the same test method using the same oil, with changing conditions such as operators, measuring equipment, test stands, test engines and time.

NOTE X1.1—Intermediate Precision is the appropriate term for this test method, rather than repeatability, which defines more rigorous within-laboratory conditions.

X1.8.3 Intermediate Precision Limit (i.p.)—The difference between two results obtained under intermediate precision conditions that would, in the long run, in the normal and correct conduct of the test method, exceed the values shown in **Table X1.1** in only one case in twenty. When only a single test result is available, the Intermediate Precision Limit can be used to calculate a range (test result \pm Intermediate Precision Limit) outside of which a second test result would be expected to fall about one time in twenty.

X1.8.4 Reproducibility Conditions—Conditions where test results are obtained with the same test method using the same test oil in different laboratories with different operators using different equipment.

X1.8.5 Reproducibility Limit (R)—The difference obtained under reproducibility conditions that would, in the long run, in the normal and correct conduct of the test method, exceed the values shown in **Table 1** in only one case in twenty. When only a single test result is available, the Reproducibility Limit can be used to calculate a range (test result \pm Reproducibility Limit) outside of which a second test result would be expected to fall about one time in twenty.

X2. SEQUENCE IIIGVS TEST PROCEDURE

X2.1 Overview—The Sequence IIIGVS test procedure was developed to support the viscosity increase requirements for Diesel Category CJ-4 (see Specification **D4485**). The Sequence IIIGVS test procedure consists of examining the percent viscosity increase data obtained at the end of a normal 100 h Sequence IIIG test method. No parts ratings or measurements are required in the Sequence IIIGVS test procedure. A separate Sequence IIIGVS report form set is available from the TMC for reporting Sequence IIIGVS test results. Do not use the Sequence IIIG Report Form Set to report Sequence IIIGVS test results.

X2.2 Preparation of Apparatus—Prepare the Sequence IIIGVS test engine in the same manner as a Sequence IIIG test engine. No special preparations are required or permitted on test engines for Sequence IIIGVS use. Do not perform Camshaft and Lifter Measurements for the Sequence IIIGVS test procedure.

X2.3 Calibration

X2.3.1 There is no stand-alone calibration system for the Sequence IIIGVS test procedure. Any stand that is considered calibrated for Sequence IIIG testing shall be considered calibrated for Sequence IIIGVS testing.

X2.3.2 No special calibration of stand instrumentation is required for Sequence IIIGVS testing.

X2.3.3 Apply Sequence IIIG percent viscosity increase Severity Adjustments (SA) to Sequence IIIGVS results.

X2.3.4 A Sequence IIIGVS test procedure start counts as one run against the Sequence IIIG calibration period in which it is run.

X2.4 Test Procedure—Conduct the Sequence IIIGVS test procedure in a calibrated IIIG test stand.

X2.5 Determination of Result—Determine the test result using **12.6**, **12.12**, and **12.13**.

X2.6 Test Reporting—Report the Sequence IIIGVS result using the standard IIIGVS report form set, available from the TMC.

X2.7 Precision and Bias

X2.7.1 Test precision for the IIIGVS test procedure is assumed to be the same as that established for the Sequence IIIG test method, which is based on reference oil test results (for operationally valid tests) monitored by the TMC. The Sequence IIIG Surveillance Panel reviews the data semiannually; contact the TMC for current industry data.

X2.7.2 Bias for the IIIGVS test procedure is assumed to be the same as that determined by applying an accepted statistical technique to Sequence IIIG test method reference oil test results. When a significant bias is determined, an SA is permitted for non-reference oil test results.

X3. SEQUENCE IIIGB TEST PROCEDURE

X3.1 Overview

X3.1.1 The Sequence IIIGB supplement to the Sequence IIIG test was developed to generate used oil samples to measure the phosphorus retention of a test lubricant after 100 h of Sequence IIIG test operation. No parts ratings or measurements are required in the Sequence IIIGB test. A separate Sequence IIIGB Report Form Set is available from the TMC for reporting Sequence IIIGB test results. Do not use the Sequence IIIG Report Form Set to report Sequence IIIGB test results. The oil samples used for measurement of the phosphorus retention in the Sequence IIIGB test are the initial oil sample, removed from the engine following the initial run-in, and the end-of-test 100 h oil sample. The phosphorus retention calculation is:

$$\text{Phosphorous Retention} = (Ca_{ii} / Ca_{i100}) \times (P_{i100} / P_{ii}) \times 100 \quad (\text{X3.1})$$

where:

Ca_{ii} = analytical results from the initial oil sample,

Ca_{i100} = analytical results from the initial oil sample,

P_{i100} = analytical results from the end-of-test oil sample,
and

P_{ii} = analytical results from the end-of-test oil sample.

Use Test Method **D5185** to measure calcium and phosphorus concentrations. For oils where calcium is not the highest concentration detergent metal, substitute the highest concentration detergent metal into the equation for calcium.

X3.2 *Preparation of Apparatus*—Prepare the Sequence IIIGB test engine in the same manner as a Sequence IIIG or IIIGA test engine; except that the pre-test camshaft and lifter measurements are not required. No special preparations are required or permitted on test engines for Sequence IIIGB testing.

X3.3 Calibration

X3.3.1 There is no stand-alone calibration system for the Sequence IIIGB test. A stand that is calibrated for the Sequence IIIG is also calibrated for Sequence IIIGB testing. Conduct a Sequence IIIGB test simultaneously with each Sequence IIIG reference oil test.

X3.3.2 No special calibration of stand instrumentation is required for Sequence IIIGB testing.

X3.3.3 A Sequence IIIGB test counts as one run against the Sequence IIIG calibration period in which it was run. A test run

as a combined Sequence IIIG, IIIGA, or IIIGB test counts as only one run against the calibration period.

X3.4 *Test Procedure*—The Sequence IIIG/B test can be conducted in one of two ways:

X3.4.1 *Stand-alone Sequence IIIGB Test*—If only a Sequence IIIGB test result is needed, conduct the test in the normal manner as detailed in Test Method D7320 with the exception of ratings, wear measurements, or assessment of stuck rings. At the end of test, report all results as a stand-alone IIIGB test using the Sequence IIIGB Report Form Set.

X3.4.2 *Combined Sequence IIIG, IIIGA, IIIGB Sequence Test*—If Sequence IIIG, IIIGA, and IIIGB test results are desired on a non-reference oil, conduct the test in the normal manner as listed in Test Method D7320, identify the test as a Combined Sequence IIIG, IIIGA, IIIGB on Report Form 1 and complete all forms in the standard Sequence IIIG, IIIGA, and IIIGB Report Form Sets including all ratings, measurements, and used oil analyses.

X3.5 *End-of-Test Oil Sample Testing*—The phosphorus and calcium elemental concentrations for all oil samples are to be reported in mg/kg as determined using Test Method **D5185**. All samples, initial and end-of-test, are to be run sequentially, in duplicate, using the same calibration (that is, as close in time as practical). Background correction, internal standard, and peristaltic pump are required. Use sample dilutions of at least 1:20. Once a dilution is established, use it for all samples from a test. Report the average of the two determinations as the final result. If the duplicate determinations are outside the repeatability calculations shown in Table 2 of Test Method **D5185**, follow the procedure shown in 6.2 of Test Method **D3244**.

X3.6 *Quality Index*—Calculate quality index results for a Sequence IIIGB test in the same manner as for the Sequence IIIG.

X3.7 *Test Reporting*—Report Sequence IIIGB test results using the standard IIIGB Report Form Set, available from the TMC.

X3.8 *Precision and Bias*—The precision and bias of this test procedure for measuring phosphorus retention has yet to be determined.

ASTM International takes no position respecting the validity of any patent rights asserted in connection with any item mentioned in this standard. Users of this standard are expressly advised that determination of the validity of any such patent rights, and the risk of infringement of such rights, are entirely their own responsibility.

This standard is subject to revision at any time by the responsible technical committee and must be reviewed every five years and if not revised, either reapproved or withdrawn. Your comments are invited either for revision of this standard or for additional standards and should be addressed to ASTM International Headquarters. Your comments will receive careful consideration at a meeting of the responsible technical committee, which you may attend. If you feel that your comments have not received a fair hearing you should make your views known to the ASTM Committee on Standards, at the address shown below.

This standard is copyrighted by ASTM International, 100 Barr Harbor Drive, PO Box C700, West Conshohocken, PA 19428-2959, United States. Individual reprints (single or multiple copies) of this standard may be obtained by contacting ASTM at the above address or at 610-832-9585 (phone), 610-832-9555 (fax), or service@astm.org (e-mail); or through the ASTM website (www.astm.org). Permission rights to photocopy the standard may also be secured from the ASTM website (www.astm.org/COPYRIGHT/).