



Standard Test Method for Flash Point by Modified Continuously Closed Cup (MCCCFP) Tester¹

This standard is issued under the fixed designation D7094; the number immediately following the designation indicates the year of original adoption or, in the case of revision, the year of last revision. A number in parentheses indicates the year of last reapproval. A superscript epsilon (ϵ) indicates an editorial change since the last revision or reapproval.

1. Scope

1.1 This test method covers the determination of the flash point of fuels, lube oils, solvents and other liquids by a continuously closed cup tester utilizing a specimen size of 2 mL, cup size of 7 mL, with a heating rate of 2.5°C per minute.

1.1.1 Apparatus requiring a specimen size of 1 mL, cup size of 4 mL, and a heating rate of 5.5°C per minute must be run according to Test Method D6450.

1.2 This flash point test method is a dynamic method and depends on definite rates of temperature increase. It is one of the many flash point test methods available and every flash point test method, including this one, is an empirical method.

NOTE 1—Flash point values are not a constant physical chemical property of materials tested. They are a function of the apparatus design, the condition of the apparatus used, and the operational procedure carried out. Flash point can, therefore, only be defined in terms of a standard test method and no general valid correlation can be guaranteed between results obtained by different test methods or where different test apparatus is specified.

1.3 This test method utilizes a closed but unsealed cup with air injected into the test chamber.

1.4 This test method is suitable for testing samples with a flash point from 35 to 225°C.

NOTE 2—Flash point determinations below 35°C and above 225°C may be performed; however, the precision has not been determined below and above these temperatures.

1.5 If the user's specification requires a defined flash point method other than this method, neither this method nor any other test method should be substituted for the prescribed test method without obtaining comparative data and an agreement from the specifier.

1.6 The values stated in SI are to be regarded as standard. Temperatures are in degrees Celsius, pressure in kilo-Pascals.

1.7 *This standard does not purport to address all of the safety concerns, if any, associated with its use. It is the responsibility of the user of this standard to establish appropriate safety and health practices and determine the applica-*

¹ This test method is under the jurisdiction of ASTM Committee D02 on Petroleum Products and Lubricants and is the direct responsibility of Subcommittee D02.08 on Volatility.

Current edition approved Nov. 1, 2004. Published November 2004. DOI: 10.1520/D7094-04.

bility of regulatory limitations prior to use. For specific warning statements, see 7.2, 8.5, and 10.1.2.

2. Referenced Documents

2.1 ASTM Standards:²

D93 Test Methods for Flash Point by Pensky-Martens Closed Cup Tester

D4057 Practice for Manual Sampling of Petroleum and Petroleum Products

D4177 Practice for Automatic Sampling of Petroleum and Petroleum Products

D6450 Test Method for Flash Point by Continuously Closed Cup (CCCFP) Tester

D6708 Practice for Statistical Assessment and Improvement of Expected Agreement Between Two Test Methods that Purport to Measure the Same Property of a Material

E300 Practice for Sampling Industrial Chemicals

2.2 ISO Standards:³

ISO Guide 34 Quality Systems Guidelines for the Production of Reference Materials

ISO Guide 35 Certification of Reference Materials—General and Statistical Principles

3. Terminology

3.1 Definitions:

3.1.1 *flash point, n*—the lowest temperature corrected to a pressure of 101.3 kPa at which application of an ignition source causes the vapors of a specimen of the sample to ignite momentarily under specified conditions of the test.

3.1.1.1 *Discussion*—For the purpose of this test method, the test specimen is deemed to have flashed when the hot flame of the ignited vapor causes an instantaneous pressure increase of at least 20 kPa inside the closed measuring chamber.⁴

² For referenced ASTM standards, visit the ASTM website, www.astm.org, or contact ASTM Customer Service at service@astm.org. For *Annual Book of ASTM Standards* volume information, refer to the standard's Document Summary page on the ASTM website.

³ Available from American National Standards Institute (ANSI), 25 W. 43rd St., 4th Floor, New York, NY 10036.

⁴ The method of detecting the flash point by monitoring the instantaneous pressure increase is covered by a patent. Interested parties are invited to submit information regarding the identification of an alternative(s) to this patented item to the ASTM International Headquarters. Your comments will receive careful consideration at a meeting of the responsible technical committee, which you may attend.

TABLE 1 Volume of Introduced Air as a Function of Sample Temperature

Sample Temperature Range (°C)	Introduced Volume of Air (mL)
below 80	0
80 to below 150	0.5 ± 0.15
150 to below 200	1 ± 0.2
200 to below 300	1.5 ± 0.3
300 and above	2 ± 0.4

3.1.2 *dynamic, adj*—the condition where the vapor above the test specimen and the test specimen are not in temperature equilibrium at the time at which the ignition source is applied.

4. Summary of Test Method

4.1 The lid of the test chamber is regulated to a temperature at least 18°C below the expected flash point. A 2 ± 0.2 mL test specimen of a sample is introduced into the sample cup. Both specimen and cup are at a temperature at least 18°C below the expected flash point; cooled if necessary. The cup is then raised and pressed onto the lid of specified dimensions to form the continuously closed but unsealed test chamber with an overall volume of 7.0 ± 0.3 mL.

4.2 After closing the test chamber, the temperatures of the test specimen and the regulated lid are allowed to equilibrate to within 1°C. Then the lid is heated at a prescribed, constant rate. For the flash tests, a high voltage arc of defined energy is discharged inside the test chamber at regular intervals. After each ignition, a variable amount of air (see Table 1) is introduced into the test chamber to provide the necessary oxygen for the next flash test. The pressure inside the continuously closed but unsealed test chamber remains at ambient barometric pressure except for the short time during the air introduction and at a flash point.

4.3 After each arc application, the instantaneous pressure increase above the ambient barometric pressure inside the test chamber is monitored. When the pressure increase exceeds 20 kPa, the temperature at that point is recorded as the uncorrected flash point, which is then corrected to barometric pressure.

5. Significance and Use

5.1 The flash point temperature is one measure of the tendency of the test specimen to form a flammable mixture with air under controlled laboratory conditions. It is only one of a number of properties which must be considered in assessing the overall flammability hazard of a material.

5.2 Flash point is used in shipping and safety regulations to define *flammable* and *combustible* materials and for classification purposes. This definition may vary from regulation to regulation. Consult the particular regulation involved for precise definitions of these classifications.

5.3 This test method can be used to measure and describe the properties of materials in response to heat and an ignition source under controlled laboratory conditions and shall not be used to describe or appraise the fire hazard or fire risk of materials under actual fire conditions. However, results of this test method may be used as elements of a fire risk assessment, which takes into account all of the factors which are pertinent to an assessment of the fire hazard of a particular end use.

5.4 Flash point can also indicate the possible presence of highly volatile and flammable materials in a relatively non-volatile or nonflammable material, such as the contamination of lubricating oils by small amounts of diesel fuel or gasoline. This test method was designed to be more sensitive to potential contamination than Test Method D6450.

6. Apparatus

6.1 *Flash Point Apparatus, Continuously Closed Cup Operation*—The type of apparatus suitable for use in this test method employs a lid of solid brass, the temperature of which is controlled electrically. Two temperature sensors for the specimen and the lid temperatures, respectively, two arc pins for a high voltage arc, and a connecting tube for the pressure monitoring and the air introduction are incorporated in the lid. Associated equipment for electrically controlling the chamber temperature is used, and a digital readout of the specimen temperature is provided. The apparatus and its critical elements are shown in Figs. A1.1 and A1.2.⁵

6.1.1 *Test Chamber*—The test chamber is formed by the sample cup and the temperature controlled lid and shall have an overall volume of 7 ± 0.3 mL. A metal to metal contact between the lid and the sample cup shall provide good heat contact but allow ambient barometric pressure to be maintained inside the test chamber during the test. Critical dimensions are shown in Fig. A1.2. The pressure inside the measuring chamber during the temperature increase is monitored. A seal that is too tight results in a pressure increase above ambient due to the temperature and the vapor pressure of the sample. A poor heat contact results in a bigger temperature difference between the sample and the heated lid.

6.1.2 *Sample Cup*—The sample cup shall be made of nickel-plated aluminum or other material with similar heat conductivity. It shall have an overall volume of 7 ± 0.3 mL and shall be capable of containing 2 ± 0.2 mL of sample. The critical dimensions and requirements are shown in Fig. A1.2.

6.1.3 *Specimen Temperature Sensor*—The specimen temperature sensor (Fig. A1.1) shall be a thermocouple (NiCr-Ni or similar) in stainless steel of 1 mm diameter with a response time of $t(90) = 3$ s. It shall be immersed to a depth of at least 2 mm into the specimen. It shall have a resolution of 0.1°C and a minimum accuracy of $\pm 0.2^\circ\text{C}$, preferably with a digital readout.

6.1.4 *Magnetic Stirring*—The apparatus shall have provisions for stirring of the sample. A rotating magnet outside the sample cup shall drive a small stirring magnet which is inserted into the sample cup after sample introduction. The stirring magnet shall have a diameter of 3 ± 0.2 mm and a length of 12 ± 1 mm. The rotation speed of the driving magnet shall be between 250 and 270 rev/min.

6.1.5 *Air Introduction*—The apparatus shall have provisions for introduction of air immediately after each flash test. The air

⁵ The sole source of supply of the continuously closed cup testers meeting these requirements known to the committee at this time are available from Grabner Instruments, A-1220 Vienna/Austria, Dr. Otto-Neurath-Gasse 1. If you are aware of alternative suppliers, please provide this information to ASTM International Headquarters. Your comments will receive careful consideration at a meeting of the responsible technical committee,¹ which you may attend.

shall be introduced by a short air pulse from a small membrane compressor by means of a T-inlet in the connecting tube to the pressure transducer. The volume of the introduced air, from 0.5 to 2 mL, is dependent on the sample temperature (see Table 1).

6.1.6 Electrical heating and thermoelectric cooling of the lid (see the Peltier element shown in Fig. A1.1) shall be used to regulate the temperature of the test chamber for the duration of the test. The temperature regulation shall have a minimum accuracy of $\pm 0.2^\circ\text{C}$.

6.1.7 A high voltage electric arc shall be used for the ignition of the flammable vapor. The energy of the arc shall be $1.3 \pm 0.3 \text{ J}$ ($1.3 \pm 0.3 \text{ Ws}$) per arc and the energy shall be applied within $19 \pm 2 \text{ m/s}$. (**Warning**—Because samples containing low flash material or having a flash point below the preset initial temperature can oversaturate the vapor inside the chamber and hence prohibit the detection of a flash point in the chosen range, a precautionary arc set at 5°C intervals is required while the lid and sample cup temperatures are equalizing.)

6.1.8 The pressure transducer for the flash point detection shall be connected to the connecting tube in the lid and shall have a minimum operational range from 80 to 177 kPa with a minimum resolution of 0.1 kPa and a minimum accuracy of $\pm 0.5 \text{ kPa}$. It shall be capable of detecting an instantaneous pressure increase above barometric pressure of a minimum of 20 kPa within 100 m/s.

NOTE 3—The monitoring of the instantaneous pressure increase above barometric pressure is one of several methods to determine a flash inside the test chamber. A pressure increase of 20 kPa corresponds to a flame volume of approximately 2.5 mL.

NOTE 4—An automatic barometric correction, which is performed according to the procedure described in 12.1, can be installed in the tester. The absolute pressure reading of the pressure transducer described in 6.1.8 may be used for the correction.

6.1.9 The introduction of a test specimen of $2.0 \pm 0.2 \text{ mL}$ shall be accomplished by the use of a pipette or syringe of the required accuracy.

7. Reagents and Materials

7.1 *Purity of Reagents*—Use only chemicals of purity specified in Table X1.1. Unless otherwise indicated, it is intended that all reagents conform to the specifications of the Committee on Analytical Reagents of the American Chemical Society where such specifications are available.⁶ Other grades may be used, provided it is first ascertained that the reagent is of sufficient purity to permit its use without lessening the accuracy of the determination.

7.1.1 *Anisole*—(**Warning**—See 7.2.)

7.1.2 *Dodecane*—(**Warning**—See 7.2.)

7.2 *Cleaning Solvents*—Use only noncorrosive solvents capable of cleaning the sample cup and the lid. Two commonly used solvents are toluene and acetone. (**Warning**—Anisole,

dodecane, toluene, acetone, and many solvents are flammable and are health hazards. Dispose of solvents and waste material in accordance with local regulations.)

8. Sampling

8.1 Obtain at least a 50 mL sample from a bulk test site in accordance with the instructions given in Practice D4057, D4177, or E300. Store the sample in a clean, tightly sealed container at a low temperature.

8.2 Do not store samples for an extended period of time in gas permeable containers, such as plastic, because volatile material may diffuse through the walls of the container. Discard samples in leaky containers and obtain new samples.

8.3 Erroneously high flash points can be obtained when precautions are not taken to avoid loss of volatile material. Do not open containers unnecessarily. Do not make a transfer unless the sample temperature is at least 18°C below the expected flash point. When possible, perform the flash point as the first test.

8.4 Samples of very viscous materials may be warmed until they are reasonably fluid before they are tested. However, do not heat the unsealed sample above a temperature of 18°C below its expected flash point.

8.5 Samples containing dissolved or free water may be dehydrated with calcium chloride or by filtering through a qualitative filter paper or a loose plug of dry absorbent cotton. Warming the sample is permitted, but it should not be heated above a temperature of 18°C below its expected flash point. (**Warning**—Because samples containing volatile material will lose volatiles and then yield incorrectly high flash points, the treatment described in 8.4 and 8.5 is not suitable for such samples.)

9. Quality Control Checks

9.1 Verify the performance of the instrument at least once per year by determining the flash point of a certified reference material (CRM) such as those listed in Appendix X1, which is reasonably close to the expected temperature range of the samples to be tested. The material shall be tested in accordance with Section 11 of this test method, and the observed flash point obtained in 11.11 shall be corrected for barometric pressure as described in Section 12. The flash point shall be within the limits stated in Table X1.1.

9.2 Once the performance of the instrument has been verified, the flash point of Secondary Working Standards (SWSs) can be determined along with their control limits. These secondary materials can then be utilized for more frequent performance checks (see Appendix X1). A performance check with a SWS shall be performed every day the instrument is in use.

9.3 When the flash point obtained is not within the limits stated in 9.1 or 9.2, follow the manufacturer's instruction for cleaning and maintenance, and check the instrument calibration (see Section 10). After any adjustment, repeat the test in 9.1 or 9.2, using a fresh test specimen, with special attention to the procedural details prescribed in this test method. (**Warning**—The use of single component verification materials, such as those listed in Table X1.1, will only prove the calibration of the equipment. It will not check the accuracy of

⁶ *Reagent Chemicals, American Chemical Society Specifications*, American Chemical Society, Washington, DC. For Suggestions on the testing of reagents not listed by the American Chemical Society, see *Annual Standards for Laboratory Chemicals*, BDH Ltd., Poole, Dorset, U.K., and the *United States Pharmacopeia and National Formulary*, U.S. Pharmacopeial Convention, Inc. (USPC), Rockville, MD.

the entire test method which includes sample handling. Losses due to evaporation of a single component material will not affect the flash point as is the case with losses of light ends in multi component mixtures.)

10. Calibration

10.1 Pressure Transducer:

10.1.1 Check the calibration of the pressure transducer when needed, as indicated from the quality control checks performed in accordance with Section 9. The calibration of the transducer is checked using the ambient barometric pressure as a reference.

10.1.2 If the displayed atmospheric pressure is not equal to the ambient barometric pressure, adjust the transducer control until the appropriate reading is observed. The ambient barometric pressure is the actual station pressure at the location of the tester at the time of measurement. (**Warning**—Many aneroid barometers, such as those used at weather stations and airports, are precorrected to give sea level readings: These shall not be used for calibration of the apparatus.)

10.2 *Temperature Sensor*—Check the calibration of the temperature sensor used to monitor the temperature of the sample against a certified reference thermometer when needed, as indicated from the quality control checks (see Section 9). Use only reference thermometers which are traceable to the National Institute of Standards and Technology (NIST) or national authorities in the country in which the equipment is used.

11. Procedure

11.1 Thoroughly clean and dry the lid together with the arc pins and the sample cup before starting the test. Be sure to remove any solvent used to clean the apparatus.

11.1.1 If the expected flash point of a sample is more than 15°C higher than the flash point of the previous sample, heat the lid together with an empty, dry sample cup to a temperature 30°C higher than the expected flash point of the new sample.

NOTE 5—The dry cup heating procedure will eliminate possible cross contamination from residual vapors.

11.2 *Expected Flash Point*—Set the initial temperature (at which actual flash point testing will start) to at least 18°C below the expected flash point. Set the final temperature to a value beyond the expected flash point.

11.2.1 *No Expected Flash Point Available*—When testing materials for which no expected flash point temperature is known, set the initial temperature to 10°C and measure the material to be tested in the manner described. This flash point result shall be considered as approximate. This approximate flash point value can be used as the expected flash point when a fresh specimen is tested in the standard mode of operation.

11.3 Set the heating rate to $2.5 \pm 0.3^\circ\text{C}/\text{min}$.

11.4 Set the ignition frequency to 5°C.

11.5 Set the air introduction volume to the values listed in **Table 1**.

11.6 Set the pressure threshold for the flash detection to 20 kPa.

11.7 Initiate the test procedure to regulate the lid to the initial temperature. When the initial temperature is reached as

indicated by the instrument, prepare to introduce the 2 ± 0.2 mL specimen of the sample.

11.8 Ensure that the sealed sample and the sample cup are at least 18°C below the expected flash point temperature. Cool if necessary.

11.8.1 Shake the sample thoroughly before opening the sample container. Extract 2 ± 0.2 mL of sample with a pipette or syringe and close the container immediately.

11.8.1.1 Transfer the extracted 2 ± 0.2 mL of this sample into the sample cup.

11.9 Insert a stirring magnet into the sample cup to ensure a consistent sample mix.

11.10 Put the sample cup onto the sample cup support of the tester, and start the apparatus.

11.11 If a flash is detected while equalizing the temperature between the sample cup and the lid (see 6.1.7), discontinue the test, and discard the result.

11.11.1 Repeat the test with a fresh specimen and with a lower initial temperature of at least 18°C below the temperature at which the flash was detected.

11.12 After the temperature between the temperature regulated lid and the specimen have equalized to within 1°C, start the actual test for the flash point.

11.12.1 Set the ignition frequency to 1°C.

11.12.2 Heat the lid with the programmed heating rate.

11.13 Stop the test when a flash is detected, or when the final temperature is reached in the case of no flash.

11.13.1 When a flash is detected at a temperature which is higher than 26°C above the initial temperature, or when a flash is detected at a temperature which is less than 10°C above the initial temperature, consider the result approximate and repeat the test with a fresh test specimen.

11.13.1.1 Adjust the expected flash point for this next test to the temperature of the approximate result.

11.13.1.2 Set the initial temperature for this fresh test specimen to 18°C below the expected flash point.

11.14 Record the specimen temperature reading at the observed flash point as the uncorrected flash point temperature.

11.14.1 If no flash point was detected within the tested temperature range, record *flash point is higher than the final temperature*.

11.15 At the conclusion of the test, cool the sample cup below 50°C to withdraw it safely.

12. Calculation

12.1 *Barometric Pressure Correction*—Observe and record the ambient barometric pressure at the time of the test. When the pressure differs from 101.3 kPa, correct the flash point as follows. (**Warning**—The barometric pressure used in this calculation must be the absolute ambient pressure for the laboratory at the time of the test. Many aneroid barometers, such as those used at weather stations and airports, are corrected to give sea level readings, and shall not be used.)

$$\text{Corrected flash point} = C + 0.25(101.3 - p) \quad (1)$$

where:

C = observed flash point in °C, and

p = ambient barometric pressure in kPa.

Round the corrected value to the nearest 0.5°C.

13. Report

13.1 Report the corrected flash point as the Test Method D7094, MCCCCFP of the test specimen.

14. Precision and Bias

14.1 The precision data were developed in a 2001 cooperative test program involving eight laboratories and using two pure chemicals, eleven fuels (pure and contaminated), and four lubricating oils (pure and contaminated). The precision statements for both repeatability and reproducibility are for flash points between 35 and 225°C.⁷

14.2 *Precision*—The precision of the procedure for modified MCCCCFP, as determined by the statistical examination of the interlaboratory test results, is as follows:

14.2.1 *Repeatability*—The difference between successive results obtained by the same operator with the same apparatus under constant operating conditions on identical test materials would, in the long run, in the normal and correct operation of the test method, exceed the following values in only one case in twenty.

Repeatability, $r = 4.1^{\circ}\text{C}$

14.2.2 *Reproducibility*—The difference between two single and independent results obtained by different operators working in different laboratories on identical material would, in the long run, in the normal and correct operation of the test method, exceed the following values in only one case in twenty.

Reproducibility, $R = 5.5^{\circ}\text{C}$

14.3 *Bias*—Since there is no accepted reference material suitable for determining bias for the procedure in this test method, bias has not been determined.

NOTE 6—Based on the sample set used in the 2001 cooperative test program, and using Practice D6708, no statistically significant bias was observed in the temperature range from 35°C to 150°C between this method and Test Method D93. The repeatability and reproducibility for D93 A for this sample set were $r = 4.1^{\circ}\text{C}$ and $R = 6.9^{\circ}\text{C}$.

15. Keywords

15.1 continuously closed cup; flammability; flash point

⁷ Supporting data are available from ASTM International Headquarters, Request RR:D02-1581.

ANNEX

(Mandatory Information)

A1. APPARATUS SPECIFICATIONS

A1.1 See Fig. A1.1 for MCCCCFP chamber assembly.

A1.2 See Fig. A1.2 for lid/cup chamber assembly and Table A1.1 for details.

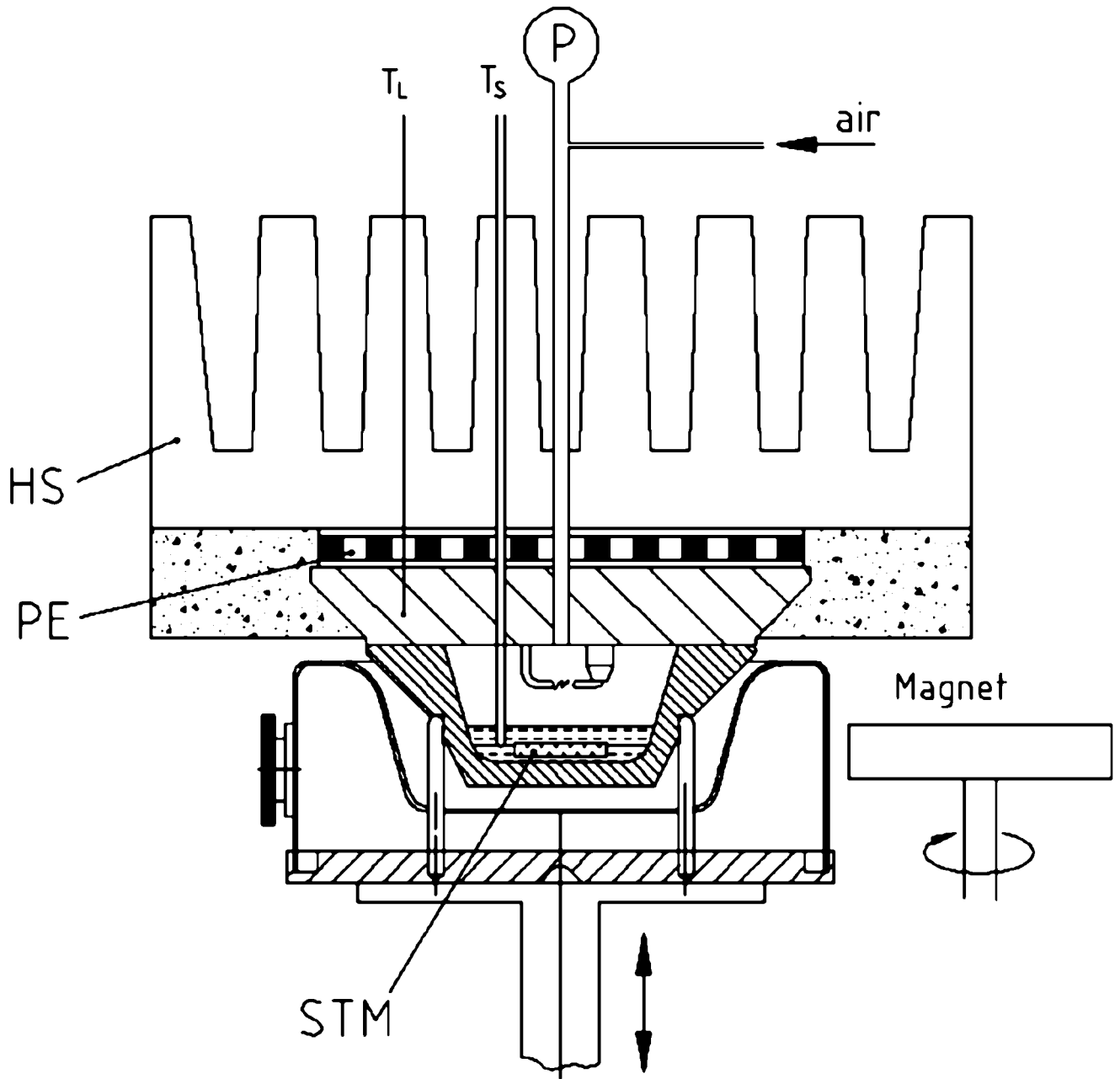

NOTE—Legend:

- T_L – Lid temperature sensor
- T_S – Sample temperature sensor
- air – Air inlet
- P – Pressure transducer
- HS – Heat sink
- PE – Peltier element
- Magnet – Rotating magnet
- STM – Stirring magnet

FIG. A1.1 MCCCFCP Chamber Assembly

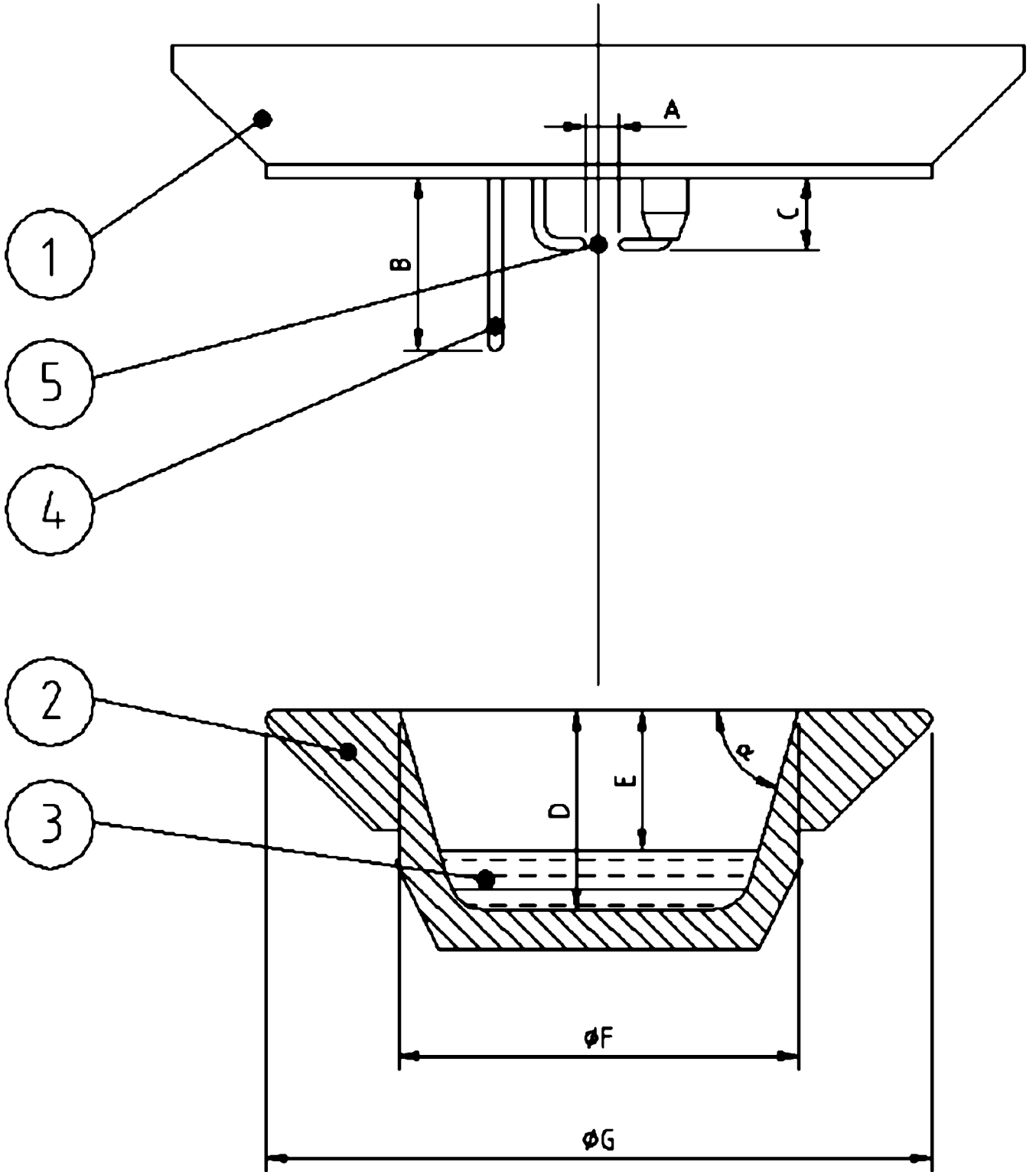

NOTE—Finish of the metal to metal contact surfaces of lid and sample cup—30 μm .
FIG. A1.2 Lid/Cup Chamber Assembly (see Table A1.1)

TABLE A1.1 Lid/Cup Chamber Assembly Details (see Fig. A1.2)

Legend:	
1	Lid with incorporated temperature sensor and electric heating, made of brass.
2	Sample cup, made of nickel-plated aluminum.
3	2 mL specimen.
4	Specimen temperature sensor (NiCr-Ni thermocouple).
5	Arc pins, made of stainless steel. Arc gap of defined length.
Measurements:	
A	2.5 ± 0.2 mm
B	14 ± 0.3 mm
C	5.5 ± 0.2 mm
D	15 ± 0.3 mm
E	10.5 mm
F	30 mm
G	50 mm
α	74°

APPENDIX

(Nonmandatory Information)

X1. APPARATUS VERIFICATION FLUIDS

X1.1 *Certified Reference Material (CRM)*—A stable hydrocarbon or other stable petroleum product with a method specific flash point established by a method specific interlaboratory study following ASTM RR:D02-1007⁸ guidelines or ISO Guides 34 and 35.

X1.1.1 Typical values of the flash point corrected for barometric pressure for some reference materials and their typical limits are given in Table X1.1 (see Note X1.1).

TABLE X1.1 MCCCCFP Typical Flash Point Values and Typical Limits for CRM

Material	Purity (Mol %)	Flash Point (°C)	Limits (°C)
Anisole	99.7+	43.3	± 1.5
Dodecane	99.5+	78.6	± 2.1

Suppliers of CRMs (see Note X1.2) will provide certificates stating the method specific flash point for each material of the current production batch. Calculation of the limits for these other CRMs can be determined from the reproducibility value of this test method, reduced by interlaboratory effect and then multiplied by 0.7 (see Research Report RR:S15-1008).⁷

NOTE X1.1—Purities, flash point values and limits stated for anisole and n-dodecane were developed in an ASTM interlaboratory program to

determine suitability of use for performance fluids in flash point test methods. Other materials, purities, flash point values, and limits can be suitable when produced according to the practices of ASTM RR:D02-1007 guidelines or ISO Guides 34 and 35. Certificates of performance of such materials should be consulted before use. (**Warning**—Handle anisole and n-dodecane with EXTREME CARE against contamination. Read the manufacturer’s Material Safety Data Sheet before using.)

NOTE X1.2—True CRM’s can only be developed once an agreed standard test method exists. As this is the first official version of this test method, certified CRM’s do not exist. The data shown in Table X1.1 pertain to the batch of anisole (purity, mole % 99.7+) and dodecane (purity, mole % 99.5+) utilized in the precision study. In the absence of certified CRMs, anisole and n dodecane of equivalent purity may be regarded as an acceptable substitute as long as this condition exists. Once CRMs are available, other materials, purities, flash point values, and limits can be suitable when produced in accordance with the practices of ASTM RR:D02-1007 guidelines or ISO Guides 34 and 35. Certificates of performance of such materials should be consulted before use, as the flash point value will vary, depending on the composition of each CRM batch.

X1.2 *Secondary Working Standard (SWS)*—a stable hydrocarbon or other petroleum product whose composition is known to remain appreciably stable.

X1.2.1 Establish the mean flash point and the statistical control limits (3σ) for the SWS, using standard statistical techniques (see ASTM MNL 7⁹).

⁸ Supporting data have been filed at ASTM International Headquarters and may be obtained by requesting Research Report RR:D02-1007.

⁹ *Manual on Presentation of Data Control Chart Analysis*, 6th Ed. Available from ASTM International Headquarters.

ASTM International takes no position respecting the validity of any patent rights asserted in connection with any item mentioned in this standard. Users of this standard are expressly advised that determination of the validity of any such patent rights, and the risk of infringement of such rights, are entirely their own responsibility.

This standard is subject to revision at any time by the responsible technical committee and must be reviewed every five years and if not revised, either reapproved or withdrawn. Your comments are invited either for revision of this standard or for additional standards and should be addressed to ASTM International Headquarters. Your comments will receive careful consideration at a meeting of the responsible technical committee, which you may attend. If you feel that your comments have not received a fair hearing you should make your views known to the ASTM Committee on Standards, at the address shown below.

This standard is copyrighted by ASTM International, 100 Barr Harbor Drive, PO Box C700, West Conshohocken, PA 19428-2959, United States. Individual reprints (single or multiple copies) of this standard may be obtained by contacting ASTM at the above address or at 610-832-9585 (phone), 610-832-9555 (fax), or service@astm.org (e-mail); or through the ASTM website (www.astm.org). Permission rights to photocopy the standard may also be secured from the ASTM website (www.astm.org/COPYRIGHT/).