



Standard Test Method for Determination of Accelerated Iron Corrosion in Petroleum Products¹

This standard is issued under the fixed designation D7548; the number immediately following the designation indicates the year of original adoption or, in the case of revision, the year of last revision. A number in parentheses indicates the year of last reapproval. A superscript epsilon (ϵ) indicates an editorial change since the last revision or reapproval.

1. Scope

1.1 This test method covers an accelerated laboratory and field procedure for the determination of corrosion of iron, in the presence of water, on samples such as gasoline and gasoline blended with 10% ethanol, E10 (Specification [D4814](#)); gasoline-blend components (except butane); diesel fuel and biodiesel B5, except Grade No. 4-D (Specification [D975](#)); biodiesel B6 to B20 (Specification [D7467](#)); diesel-blend component such as light cycle-oil; No.1 fuel oil, No.2 fuel oil (Specification [D396](#)); aviation turbine fuel (Specification [D1655](#)).

1.2 The values stated in SI units are to be regarded as the standard. The values in parentheses are for information only.

1.3 *This standard does not purport to address all of the safety concerns, if any, associated with its use. It is the responsibility of the user of this standard to establish appropriate safety and health practices and determine the applicability of regulatory limitations prior to use.*

2. Referenced Documents

2.1 ASTM Standards:²

- [A108](#) Specification for Steel Bar, Carbon and Alloy, Cold-Finished
- [D97](#) Test Method for Pour Point of Petroleum Products
- [D396](#) Specification for Fuel Oils
- [D665](#) Test Method for Rust-Preventing Characteristics of Inhibited Mineral Oil in the Presence of Water
- [D975](#) Specification for Diesel Fuel Oils
- [D1193](#) Specification for Reagent Water
- [D1655](#) Specification for Aviation Turbine Fuels
- [D4814](#) Specification for Automotive Spark-Ignition Engine Fuel

¹ This test method is under the jurisdiction of ASTM Committee [D02](#) on Petroleum Products and Lubricants and is the direct responsibility of Subcommittee [D02.14](#) on Stability and Cleanliness of Liquid Fuels.

Current edition approved June 15, 2009. Published September 2009. DOI: 10.1520/D7548-09.

² For referenced ASTM standards, visit the ASTM website, www.astm.org, or contact ASTM Customer Service at service@astm.org. For *Annual Book of ASTM Standards* volume information, refer to the standard's Document Summary page on the ASTM website.

[D7467](#) Specification for Diesel Fuel Oil, Biodiesel Blend (B6 to B20)

[G15](#) Terminology Relating to Corrosion and Corrosion Testing

2.2 Other Standards:

[070 M20 of BS 970-1](#) or European Steel C22E number [1.1151](#) Carbon and Carbon Manganese Steels including Free Cutting Steels

3. Terminology

3.1 Definitions:

3.1.1 *corrosion, n*—chemical or electrochemical reaction between a material, usually a metal, and its environment that produces a deterioration of the material and its properties. **G15**

3.1.2 *rust, n*—corrosion product consisting primarily of hydrated iron oxide.

3.1.2.1 *Discussion*—Rust is a term properly applied only to ferrous alloys. **G15**

3.2 Acronyms:

3.2.1 *TP*—temperature probe.

4. Summary of Test Method

4.1 A polished iron corrosion test-rod is immersed in 50 mL of the sample being tested and heated to 37.8°C (100°F), at which point 5 mL of reagent water, Type III or better, is added to the sample. Sample temperature is maintained between 37 to 39°C (98 to 102°F), with the target being 37.8°C (100°F), for 1 h. At the end of the heating period, test-rod is removed, rinsed, and examined for the degree/category of corrosion against the “ASTM Iron Corrosion Rating Chart—Test Method D7548.”

5. Significance and Use

5.1 In general, wherever the possibility exists of water getting mixed with products/material (covered under [1.1](#)) the results obtained by this test method will indicate the degree to which corrosion of iron components can be expected.

5.2 Test also determines the antirust properties of products/material (covered under [1.1](#)) in preparation for the various stages through which the tested product may pass prior to or during its transport through a pipeline.

5.3 Test results are also meant to show whether or not the dosage levels and type of iron corrosion inhibitor added to a product/material (covered under 1.1) is sufficient for achieving the desired protection of affected assets such as storage tanks, process lines, and shipment systems.

6. Apparatus

6.1 *Stirring Hotplate*,^{3,4} Single or multi-position (see Appendix X1), ceramic top, capable of accommodating Accelerated Iron Corrosion Test (AICT) apparatus specified in A1.1. Stirrer should be capable of stirring at a rate of 900 ± 100 rpm.

6.2 *Water Bath*—Beaker, 150 to 200 mL capacity, borosilicate glass, containing 100 mL of distilled water, or other type of water bath capable of accommodating Accelerated Iron Corrosion Test (AICT) apparatus specified in A1.1.

6.3 *Test Jar*—Cylindrical, clear glass, 90-mL capacity, flat bottom, 115 to 125 mm (4.53 to 4.92 in.) in height, 33.2 to 34.8 mm (1.31 to 1.37 in.) outside diameter, 30.0 to 32.4 mm (1.18 to 1.28 in.) inside diameter, 1.6 mm (0.06 in.) maximum wall thickness.

NOTE 1—The pour point test jar specified in Test Method D97 meets this requirement. A test jar meeting requirements of 6.3 and graduated at 50 mL is more suitable.

NOTE 2—Optionally, to prevent accidental breakage of the test jar, a rubber O-ring, 32 mm (1.25 in.) inside diameter, and 3 mm (0.12 in.) thick, could be slipped over the test jar up to about 25 mm (1.0 in.) below its rim.

6.4 *Cover*,^{4,5} *Test Jar*—Plastic, such as high density polyethylene (HDPE), with three holes, meeting dimensions and features seen and outlined in A1.2.

6.5 *Corrosion Test Rod*,^{4,6, 7} With a plastic or polytetrafluoroethylene (PTFE) holder; round, threaded steel rod, tapered at one end; 81 mm (3.19 in.) long, including the 12.7 mm (0.5 in.) long threaded portion, and 12.7 mm (0.5 in.) in diameter. See A1.3. Test rod should be made of steel conforming to Grade 1015, 1018, 1020 or 1025 of the Specifications for Cold Finished Carbon Steel Bars and Shafting (Specification A108, or to 070 M20 of BS 970-1 or European Steel C22E number 1.1151). If these steels are unavailable, other equivalent steels may be used, provided that they are satisfactory according to comparative tests using this test method.

6.5.1 *Holder*,^{4,6} Ethanol-resistant plastic or PTFE. Total length: 63.5 mm (2.5 in.), with a 2-step handle at top which is disc-type, ~22.2 mm (0.875 in.) in diameter by 15.9 mm (0.625 in.) thick. Below this is a circular step or rim which is ~17.5 mm (0.69 in.) diameter by 6.4 mm (0.25 in.) thick. The

stem portion of the holder is ~41.3 mm (1.625 in.) long by 12.7 mm (0.5 in.) in diameter, with a ~6.4 mm (0.25 in.) female-threaded hole in the bottom to accept the male-threaded corrosion rod.

6.6 *Temperature Probe*,^{4,8} Digital, calibrated, with stem about 200 mm (8 in.) long by 3.0 mm (0.125 in.) in diameter and covering a temperature range of about 20°C (68°F) to at least 60°C (140°F).

NOTE 3—Calibrated, digital temperature probe, or equivalent calibrated temperature measurement device, covering a range of -50°C (-58°F) to +300°C (+572°F) will be suitable. Alternatively, calibrated thermocouples may be used.

6.7 *Stirring Bar*—Magnetic, PTFE (polytetrafluoroethylene)-coated, 25.4 ± 2.54 mm (1.0 ± 0.1 in.) long by 8 ± 0.8 mm (0.31 ± 0.03 in.) in diameter.

6.8 *Syringe*—Plastic, 5 mL, with 63.5 mm (2.5 in.) long needle, 5 cc syringe and needle, or any other equivalent syringe and needle.

6.9 *Timing Device*—Electronic or manual, capable of measuring the test duration with an accuracy of at least 1%.

6.10 *Grinding and Polishing Apparatus*—Any suitable apparatus, with a mounting or bench stand, capable of rotating at 1700 to 1800 rpm, and having the means to mount a suitable chuck^{4,9} into which the corrosion test rod can be screwed in. See A1.4.

7. Reagents and Materials

7.1 *Reagent Water*—Type III or better, Specification D1193.

7.2 *Wash Solvent*.

7.2.1 *2,2,4-trimethylpentane (isooctane)*—Minimum 99.75% purity. (**Warning**—Flammable. Health hazard.)

7.2.2 *Acetone*—Minimum 99.5% purity. (**Warning**—Flammable. Health hazard.)

7.3 *Hydrochloric Acid (HCl)*—Prepare 15% solution by dissolving 42 mL of concentrated HCl in 100 mL distilled water. (**Warning**—Corrosive. Burn hazard.)

7.4 *Polishing Material*—Abrasive cloth roll^{4,10}; silicon carbide, C-100 open mesh, 38 mm width by 22.5 m length (1.5 in. by 25 yd) roll.

7.5 *Magnifier*—Lighted, 2× magnification power.

7.6 *Lintless Cloth or Tissue*.

7.7 *Camel's Hair Brush*.

7.8 *O-ring*—Rubber, about 32 mm (1.25 in.) internal diameter, and 3 mm (0.12 in.) thick.

7.9 *Watch-glass*—For covering 150 mL bath beakers, 65 mm (2.6 in.) in diameter.

7.10 *Absorbent Paper Towel*—Any suitable type, for absorbing water from the outside of the test jar.

7.11 *Gloves*—Disposable, acid-resistant to 15% HCl solution, and resistant to hydrocarbons used in this test method.

³ The sole source of supply of the apparatus "Super-Nuova" Multi position stirring hot plate, Model No. SP135935Q known to the committee at this time is Thermo Fisher Scientific, 2000 Park Lane Dr., Pittsburgh, PA 15275-9952.

⁴ If you are aware of alternative suppliers, please provide this information to ASTM International Headquarters. Your comments will receive careful consideration at a meeting of the responsible technical committee,¹ which you may attend.

⁵ The sole source of supply of the apparatus known to the committee at this time is K & C Manufacturing, 210 S. Main, Newkirk, OK 74647.

⁶ The sole source of supply of the apparatus, Test rod and holder—Part No. K30130, known to the committee at this time is Koehler Instruments Co., 1595 Sycamore Ave, Bohemia, NY 11716.

⁷ The sole source of supply of the apparatus, Test rod only—Part No. 408-A (SAE-1018), known to the committee at this time is Metaspec LLC, 790 W Mayfield Blvd., San Antonio, TX 78211.

⁸ The sole source of supply of the apparatus, Part No. 14-648-44, known to the committee at this time is Thermo Fisher Scientific, 81 Wyman St., Waltham, MA 02454.

⁹ The sole source of supply of the apparatus, Part No. K30100, known to the committee at this time is Koehler Instrument Co., 1595 Sycamore Ave., Bohemia, NY 11716.

¹⁰ The sole source of supply of the apparatus, Part No. 8230A76, known to the committee at this time is McMaster-Carr Supply Co., PO Box 4355, Chicago, IL 60680-4355.

8. Preparation of Corrosion Test Rod

8.1 Wear clean gloves whenever handling the corrosion test rod.

8.2 If the corrosion test rod is new, first clean it with acetone or isooctane.

8.3 Mount it in the chuck of the grinding and polishing apparatus, and rotate it at a speed of 1700 to 1800 rpm.

8.3.1 Apply a new strip of the C-100 abrasive cloth perpendicular to the long axis of the test rod so that circular grooves are formed all along the length of the rod, not criss-cross, or in any other irregular manner.

8.3.2 Polish just enough to get rid of rust/other spots; do not overpolish. Discard reused rods when the diameter is reduced to 9.5 mm (0.375 in.).

8.3.3 To ensure that the flat shoulder (that portion of the test rod which is perpendicular to the threaded stem) is free of rust, polish this area by holding a strip of the abrasive cloth between the chuck and the shoulder while rotating the test rod for a brief period.

8.3.4 Remove the test rod from the chuck. Wipe lightly with a clean, dry, lintless cloth or tissue, or brush lightly with a camel's hair brush.

NOTE 4—Check test rod with a lighted, 2× magnification power magnifier to ascertain freedom from rust/other spots, and completion of polishing operation.

8.3.5 Attach test rod to the holder, and, within 1 min, either immerse it in the sample to be tested through the 12.7 mm (0.5 in.) hole of the test jar cover, or, store it under isooctane up to 1 h before use.

9. Preparation of the Test Jar and Magnetic Stirring Bar

9.1 If the test jar or stirring bar is found to have a film of rust on it, treat it with a small amount of 15% hydrochloric acid solution to clean out all the rust, then,

9.2 Wash it thoroughly with deionized water to free it from the acid, and finally,

9.3 Rinse with acetone and dry with lint-free paper or cloth before using.

10. Procedure

10.1 Prepare the corrosion test rod, test jar and magnetic stirring bar in accordance with Sections 8 and 9.

10.2 Prepare the test jar cover assembly by inserting the previously polished corrosion test rod with its holder down into the 12.7 mm (0.5 in.) hole up to its ridge. The tip of the rod should be about 104 mm (4.1 in.) below the top of the cover.

10.3 Insert the external thermocouple or the digital TP through one of the 3.2 mm (0.125 in.) holes in the cover such that 57 mm (2.25 in.) of its stem is below the top of the cover. This should place the stem about 12.7 mm (0.5 in.) under the sample surface. Switch on the TP to display in degrees Celsius (degrees Fahrenheit).

NOTE 5—Time interval between 10.2 and 10.3 should not exceed 1 min.

NOTE 6—Tests should be run in well-ventilated spaces, or in a vented hood, because of the release of material from samples which are highly volatile, or which may contain potentially hazardous material.

10.4 Transfer 50 mL of sample into a clean test jar, gently introduce a stirring bar into the jar, and within 1 min, cover it with the assembly prepared under 10.2 and 10.3.

10.5 Put the test jar assembly into the water bath. If necessary, add water to the bath to bring its level up to the rim of the beaker.

10.6 When using a stirring hotplate *without* its own external thermocouple, switch it on at this point, and set it for achieving sample temperature of 37 to 39°C (98 to 102°F) and a stirring rate of 100 ± 10 rpm. When using the Super-Nuova^{3,4} stirring hotplate, with its own external calibrated thermocouple, switch it on after ensuring that its thermocouple has been placed in one of the samples being tested or in the water bath. Set its target sample temperature at 38°C (100°F), and stirring rate at 100 ± 10 rpm.

10.7 When the sample temperature reaches between 37 to 39°C (98 to 102°F), inject, using the 5 cc syringe, 5 mL of the Type III or better reagent water into the sample, through the other 3.2 mm (0.125 in.) hole. *Note the time.*

10.8 Gradually increase the stirring rate of the sample and set it at 900 ± 100 rpm, while keeping the target sample temperature set at 38°C (100°F). When using the Super-Nuova^{3,4} stirring hotplate, besides setting the stirring rate at 900 ± 100 rpm and target sample temperature at 38°C (100°F), also set testing time for 1-h operation.

10.9 Monitor sample temperature at least once every 15 min during the course of the test. If necessary, make appropriate adjustments, for example to the hotplate temperature setting, to maintain sample temperature between 37 to 39°C (98 to 102°F), with the target temperature being 37.8°C (100°F). When using the Super-Nuova^{3,4} stirring hotplate, if necessary, make appropriate adjustments, for example, to the hotplate temperature setting in order to maintain sample temperature between 37 to 39°C (98 to 102°F).

10.10 Stop the test when the total test time of 1 h ± 5 min has elapsed from the addition of 5 mL of reagent water to the sample. Carefully remove the test jar from the water bath, and drain as much water as possible from the outside of the jar back into the bath. Dry the jar from outside with an absorbent towel or acetone.

10.11 Remove the test jar cover assembly from the sample. If the magnetic stirrer is adhering to the TP stem, release it before going further. Rinse the test rod with a stream of acetone.

10.12 Carefully pull out the test rod from the test jar cover. Within the next 5 min, with the aid of a lighted 2× magnification magnifier, inspect the test rod from all around for evaluating its corrosion rating using the “ASTM Iron Corrosion Rating” Chart (see Fig. 1 and Section 11).

11. Interpretation of Results

11.1 Rating shall be based exclusively on the portion of the test specimen exposed within the test fluid. Rust formed during the test has had limited opportunity to darken, and all etching or deposition of solids not removed by rinsing with acetone or isooctane, excluding white spots, shall be considered as rust.

11.2 Rating shall be expressed according to the following scale:

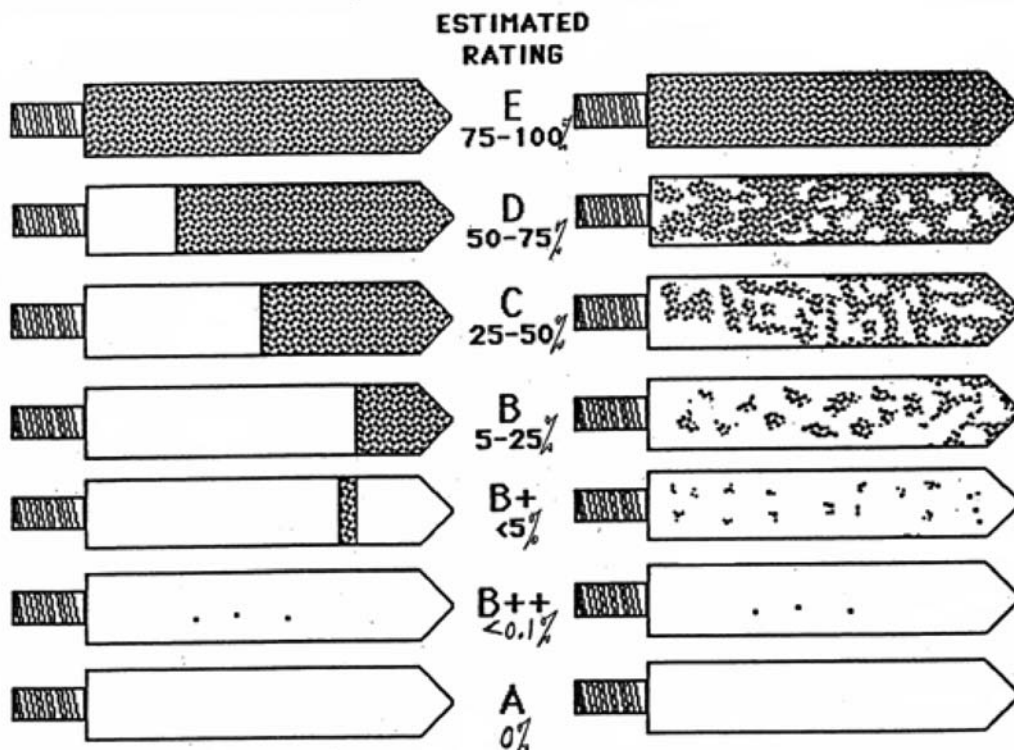

Rating shall be based exclusively on the portion of the test specimen exposed within the test fluid. Rust formed during the test has had limited opportunity to darken, and all etching or deposition of solids not removed by washing with naphtha or isooctane shall be considered rust.

Final inspection shall be made with a lighted glass of 2X magnification.

Rating shall be based on that portion of the test specimen that has changed, and shall be expressed according to the following scale:

Rating	Proportion of Test Surface Rusted (%)
A	0
B++	Less than 0.1 (2 or 3 spots of no more than 1 mm diameter)
B+	Less than 5
B	5 to 25
C	25 to 50
D	50 to 75
E	75 to 100

NOTE—This figure is from an outdated NACE publication. For information on current NACE standards, please visit www.nace.org or contact NACE FirstService at firstservice@nace.org.

FIG. 1 ASTM Iron Corrosion Rating Chart

Rating	Proportion of Test Surface Rusted (%)
A	0
B++	Less than 0.1 (2 or 3 spots of no more than 1 mm (0.04 in.) diameter)
B+	Less than 5
B	5 to 25
C	25 to 50
D	50 to 75
E	75 to 100

12. Report

12.1 Report the corrosiveness in terms of one of the ratings arrived at after inspection of the corrosion test rod based on 10.12, 11.1 and 11.2. In case of uncertainty between two adjacent ratings, the more severe rating shall be applied.

13. Precision and Bias

13.1 *Precision*—The precision of this test method has not been determined.

13.2 *Bias*—The procedure in this test method has no bias because the results of accelerated iron corrosion are defined only in terms of this test method.

14. Keywords

14.1 aviation turbine fuel; biodiesel; corrosion; corrosion rating chart; diesel; ethanol-blended gasoline; gasoline; gasoline-blend components; iron; light cycle oil; No. 1 fuel oil; No. 2 fuel oil; reagent water; rust

(Mandatory Information)

A1. APPARATUS

A1.1 Accelerated Iron Corrosion Test Apparatus

A1.1.1 See Fig. A1.1.

A1.2 Cover Test Jar

A1.2.1 See Fig. A1.2.

A1.3 Test Rod and Holder

A1.3.1 See Fig. A1.3 and Test Method D665.

A1.4 Chuck for Polishing Test Rods

A1.4.1 See Fig. A1.4 and Test Method D665.

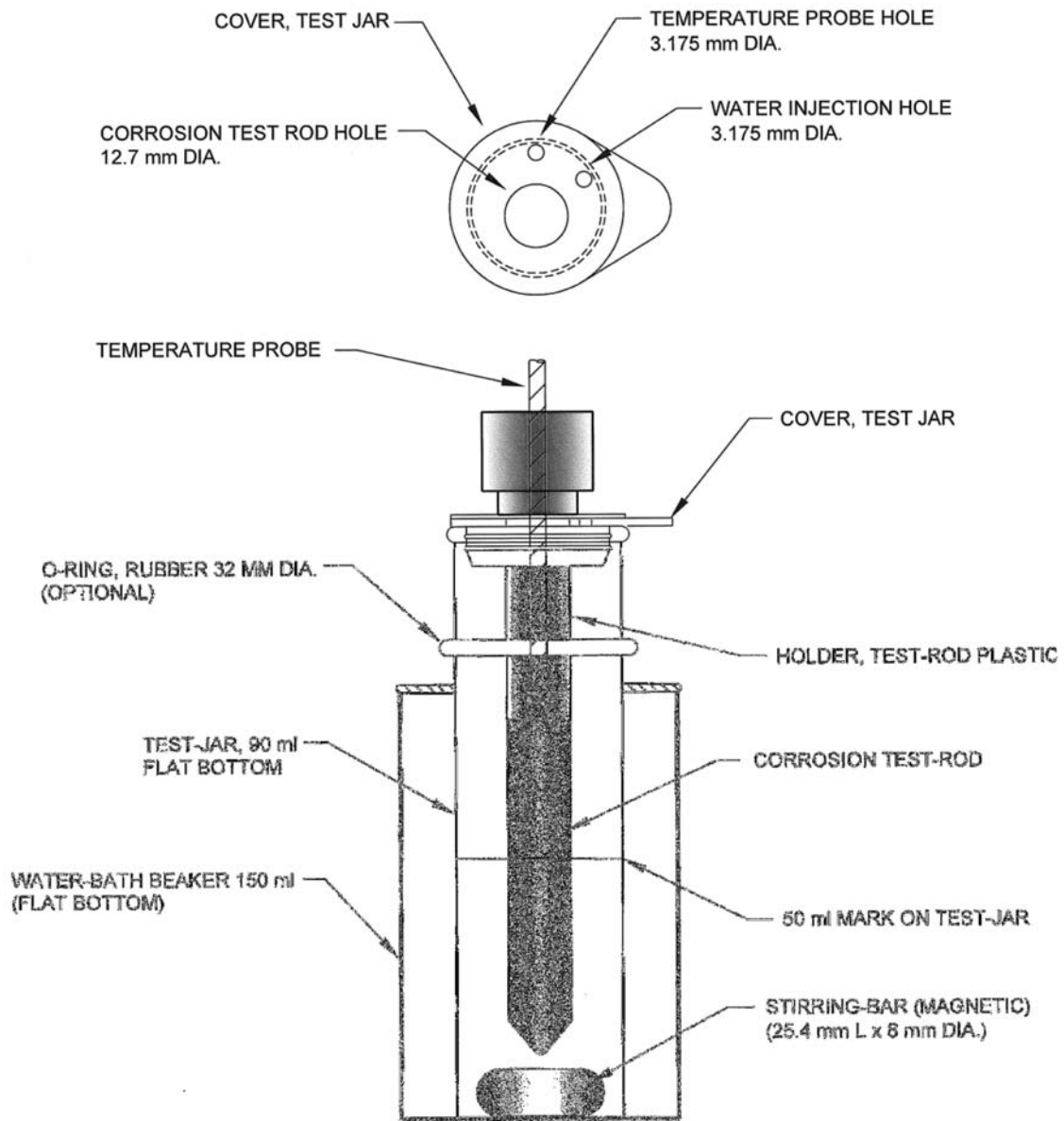
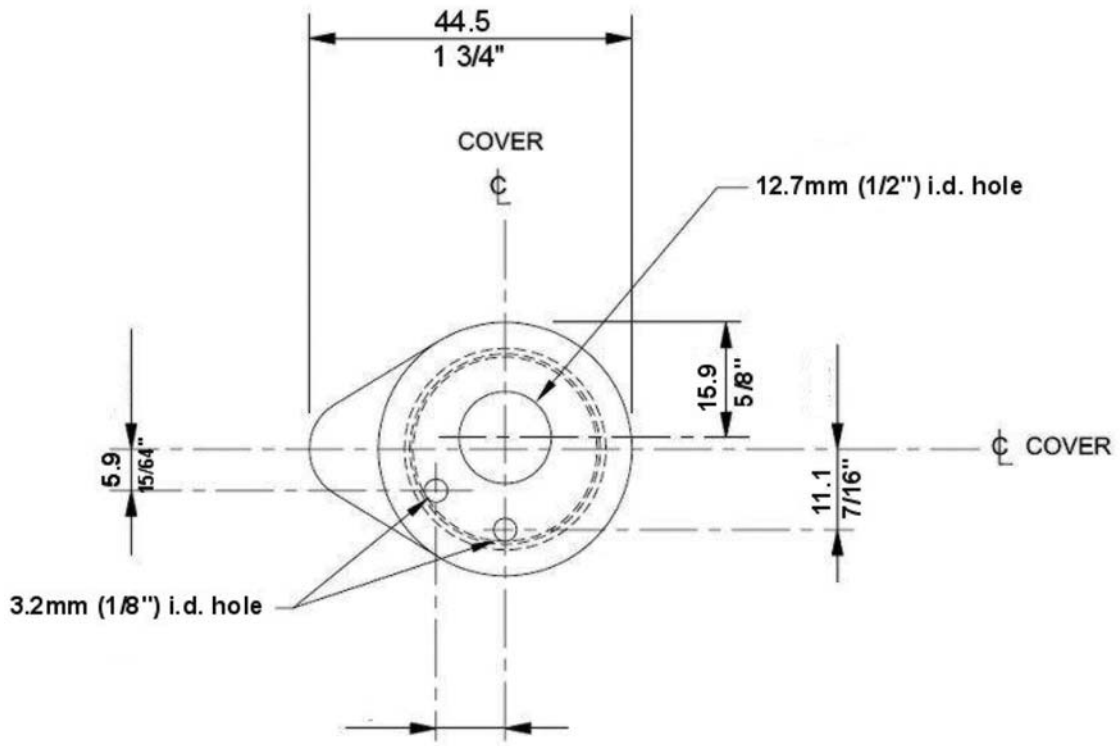
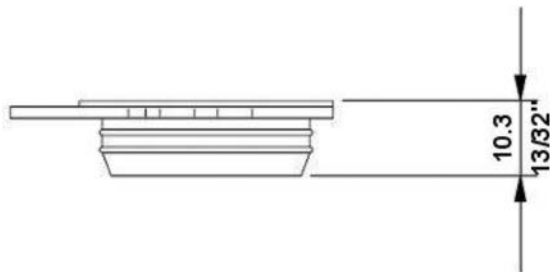

FIG. A1.1 Accelerated Iron Corrosion Test Apparatus



PLAN



ELEVATION

NOTE—All units are in millimetres, unless otherwise specified. All dimensions, unless otherwise stated, shall be within normal manufacturing tolerances.

FIG. A1.2 Cover Test Jar

TEST ROD

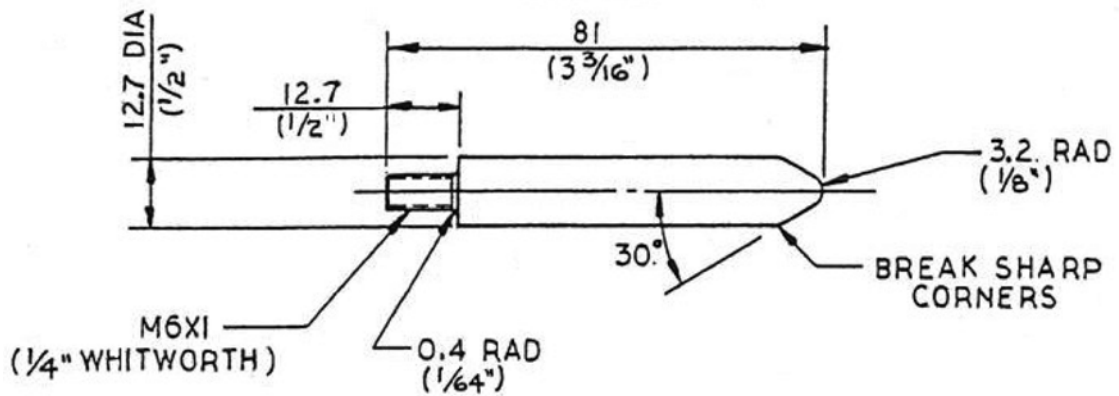

TEST ROD HOLDER

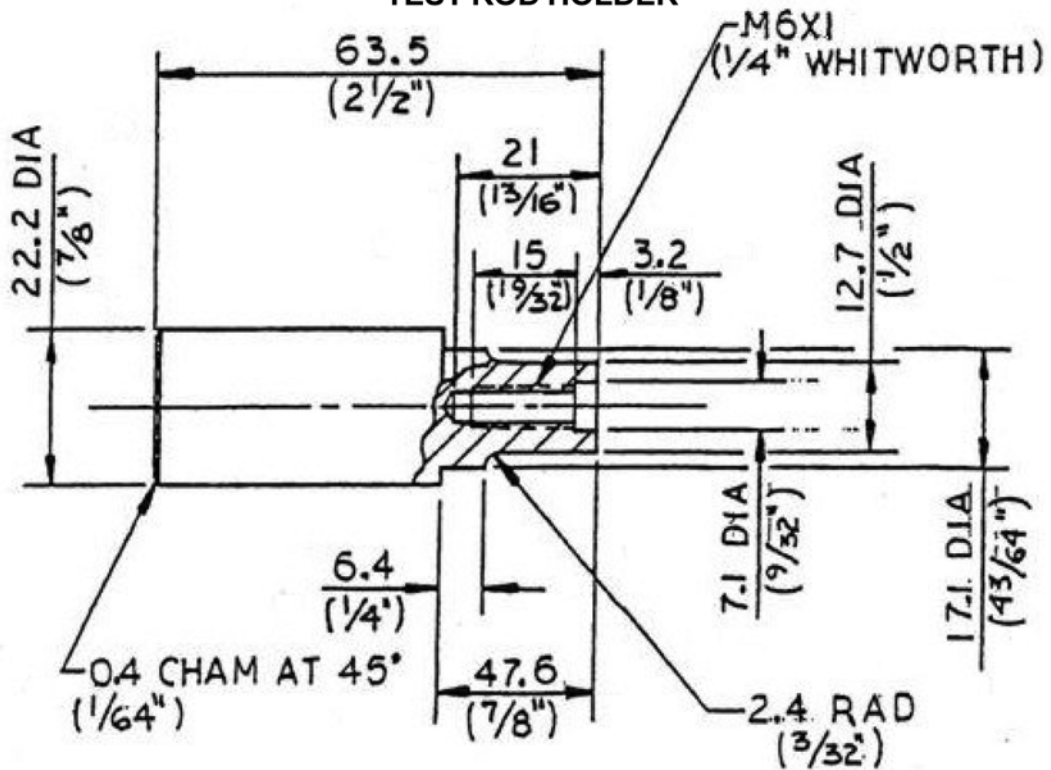

NOTE—All units are in millimetres, unless otherwise specified. All dimensions, unless otherwise stated, shall be within normal manufacturing tolerances.

FIG. A1.3 Test Rod and Holder

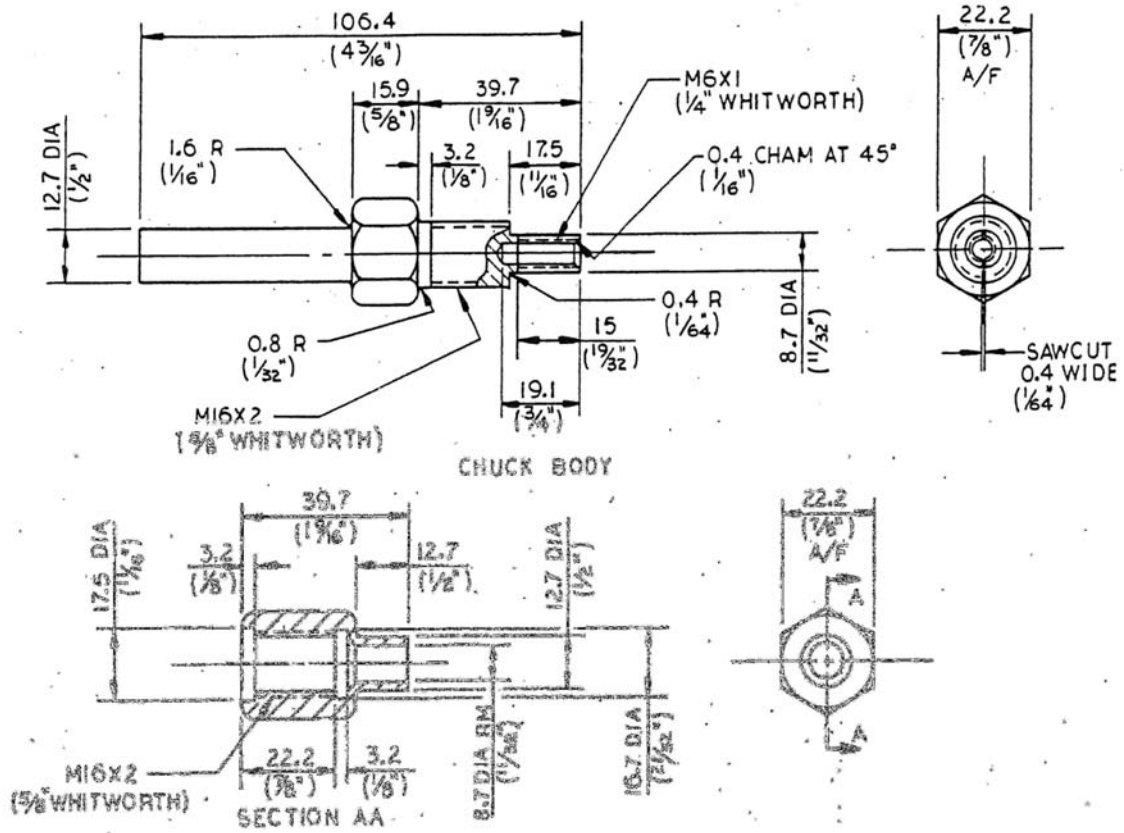

NOTE—All units are in millimetres, unless otherwise specified. All dimensions, unless otherwise stated, shall be within normal manufacturing tolerances.

FIG. A1.4 Chuck for Polishing Test Rods

APPENDIX

(Nonmandatory Information)

X1. APPARATUS

X1.1 4-Place Accelerated Iron Corrosion Test Apparatus

X1.1.1 See Fig. X1.1.

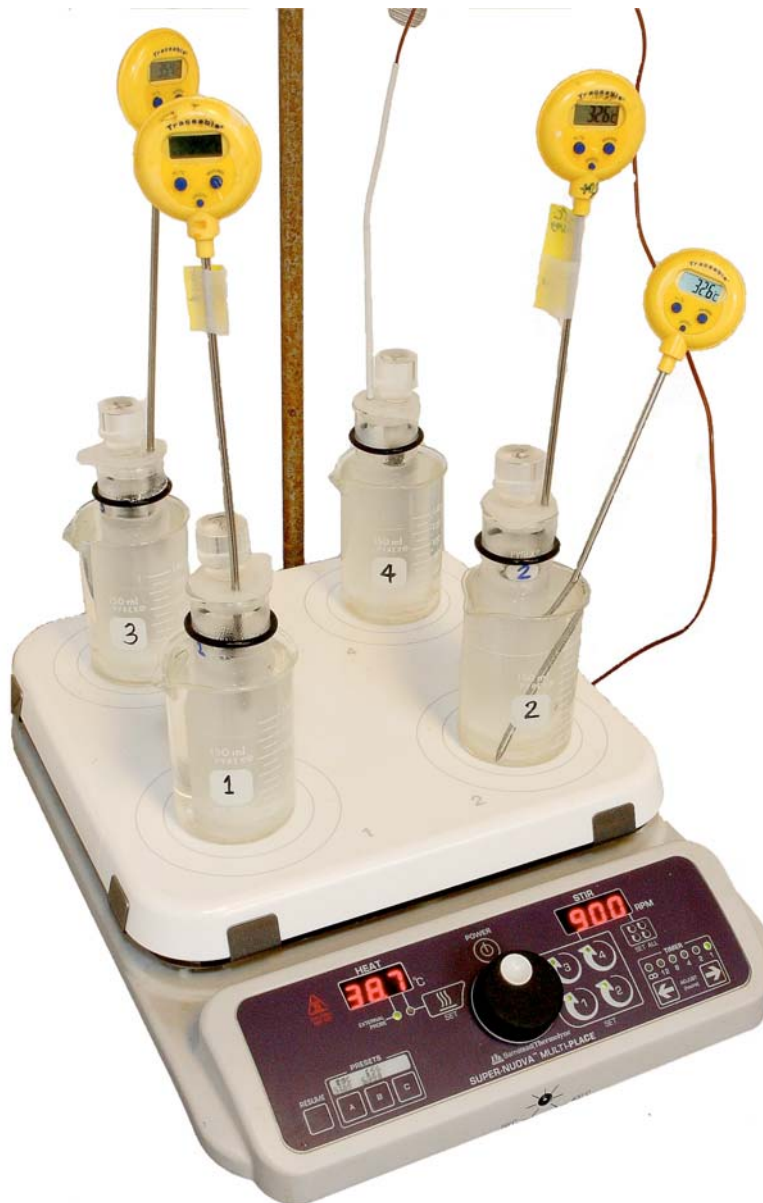

FIG. X1.1 4-Place Accelerated Iron Corrosion Test Apparatus

ASTM International takes no position respecting the validity of any patent rights asserted in connection with any item mentioned in this standard. Users of this standard are expressly advised that determination of the validity of any such patent rights, and the risk of infringement of such rights, are entirely their own responsibility.

This standard is subject to revision at any time by the responsible technical committee and must be reviewed every five years and if not revised, either reapproved or withdrawn. Your comments are invited either for revision of this standard or for additional standards and should be addressed to ASTM International Headquarters. Your comments will receive careful consideration at a meeting of the responsible technical committee, which you may attend. If you feel that your comments have not received a fair hearing you should make your views known to the ASTM Committee on Standards, at the address shown below.

This standard is copyrighted by ASTM International, 100 Barr Harbor Drive, PO Box C700, West Conshohocken, PA 19428-2959, United States. Individual reprints (single or multiple copies) of this standard may be obtained by contacting ASTM at the above address or at 610-832-9585 (phone), 610-832-9555 (fax), or service@astm.org (e-mail); or through the ASTM website (www.astm.org).